



The Corporation of the Town of Tillsonburg Development Guidelines and Design Criteria

Operations Services
Customer Service Centre
10 Lisgar Avenue
Tillsonburg, Ontario
N4G 5A5
Tel: 519-688-3009
Fax: 519-688-0759

Date: December 2022



**TOWN OF TILLSONBURG
DEVELOPMENT GUIDELINES AND DESIGN CRITERIA
TABLE OF CONTENTS**

GENERAL PREFACE SECTION 1

SUBDIVISION APPROVAL PROCESS SECTION 2

SUBDIVISION SUBMISSION REQUIREMENTS SECTION 3

SITE PLAN APPROVAL PROCESS..... SECTION 4

SITE PLAN SUBMISSION REQUIREMENTS..... SECTION 5

SITE PLAN ADDITIONAL GUIDELINES SECTION 6

ROADWAYS SECTION 7

STREETLIGHTING SECTION 8

UTILITIES SECTION 9

STORM SEWERS SECTION 10

STORMWATER MANAGEMENT SECTION 11

SANITARY SEWERS..... SECTION 12

WATERMAINS SECTION 13

LOT GRADING SECTION 14

PARKLANDS AND STREETSCAPING SECTION 15

TOWN OF TILLSONBURG STANDARD DRAWINGS APPENDIX A

TOWN OF TILLSONBURG DESIGN SHEETS..... APPENDIX B



TABLE OF CONTENTS
Operations Services
The Corporation of the Town of Tillsonburg
Development Guidelines and Design Criteria

REVISION NUMBER	DATE	DESCRIPTION	REVISED BY
1.1	02/15/2022	Final Draft	Engineering Department



Section 1



Table of Contents

1	GENERAL PREFACE	1
1.1	About the Town	1
1.2	Purpose of the Document.....	1
1.3	Definitions and Abbreviations	2
1.4	Other Reference Documents	6
1.5	Permits and Approvals	6

1 GENERAL PREFACE

1.1 About the Town

The Town of Tillsonburg is a prosperous community in Oxford County, Ontario, with a population of approximately 20,000. The Town is responsible for stormwater management, storm sewers, road networks, sidewalks, drainage ditches, bridges, and culverts. Oxford County owns and is responsible for the sanitary and water infrastructure design requirements. The Town is the official Operating Authority of the County owned linear water and sanitary infrastructure within the Town Limits.

1.2 Purpose of the Document

The Development Guidelines and Design Criteria are intended to provide the Town, consulting engineers, contractors, developers and the general public with a common reference to ensure the consistent application of design and construction practices of municipal infrastructure within the Town.

The manual is intended to aid in the planning, design activities of linear infrastructure for new site developments, subdivision developments and the retrofit of existing infrastructure.

The use of this manual does not absolve the Proponent's Consultant from their professional obligations in applying sound engineering principles and industry best practices for a solution that is practical, economical, efficient, safe and sustainable to operate and maintain by the Town.

This manual does not supersede, nor replace any legislation governing the design and construction of linear municipal infrastructure. The Proponent's Consultant shall be fully familiar with legislative requirements as they relate to the subject infrastructure.

This manual will be reviewed and updated periodically to stay current with construction standards, industry best practices and to remain in compliance with regulatory requirements. It is the responsibility of all users to ensure they are referencing the most recent version of this manual.

The information provided is not intended to hinder innovation, rather is rooted on meeting performance requirements over the lifecycle of the infrastructure. The Proponent is encouraged to provide innovative solutions, where applicable.

1.3 Definitions and Abbreviations

The following contains definitions for terms used throughout the manual.

TERM	DEFINITION
AODA	Accessibility for Ontarians with Disabilities Act.
Applicant	Persons submitted to the Town on behalf of a proposed development.
ASTM	American Society for Testing and Materials.
AWWA	American Water Works Association.
ANSI	American National Standards Institute.
Backfill	All materials placed at 300 mm or above the watermain or sewer.
Bedding, Embedment and Cover	All materials placed between the trench bottom and 300 mm above the watermain or sewer.
B.C.	Beginning of Curves
Binder Course	A Hot Mix Asphalt (HMA) course between a surface course and either a granular base course or stabilized base course, an existing pavement, or another HMA binder course.
Boulevard	Portion of the road allowance between the adjacent property line and the edge of the travelled portion of the highway or the edge of the shoulder, where such exists, furthest from the travelled portion of the highway.
CPO	Oxford County Community Planning Office
Consulting Engineer	The Professional Engineer responsible for the planning and design of the municipal infrastructure, performing those duties with the standard of care prescribed by the Professional Engineers Ontario (PEO).
Contractor	Any person, persons or corporation undertaking the installation of municipal infrastructure and services in the Town.
CSA	CSA Group (Formerly Canadian Standards Association)

TERM	DEFINITION
Developer	A person, persons or corporation who has applied to subdivide and/or develop and/or service an existing parcel of land, whether as the owner or an agent for the owner of the land.
E.C.	End of Curves
Engineer of Record	The Professional Engineer who completed the original subdivision design and overall grading plan, performing those duties with the standard of care prescribed by the Professional Engineers Ontario (PEO).
Easement	A right of use over the property of another. Common examples of easements include the right of a Municipal corporation to run a sewer line across a strip of an owner's land. Easement requirements for infrastructure will be determined on an individual project basis.
ESA	Electrical Safety Authority
FSR	Functional Servicing Report - A FSR describes the layout of the development and required infrastructure including detailed engineering to demonstrate the feasibility of the services requiring approval from the Town and County. The FSR ensures that the proposed development can be serviced for its intended use, and that all on-site and off-site servicing requirements are identified.
HSU	A heavy single unit vehicle is a vehicle with a gross weight or registered weight of over 5,000 kg. Examples of heavy single unit vehicles are single unit trucks, tractors, fire trucks, and buses.
Hot Mix Asphalt	Hot mixed, hot laid asphaltic concrete. The terms are used interchangeable. HMA may include recycled or specialty mixes.
I/I	Inflow and Infiltration
Inflow	Water from rainfall or snow melt that enters the wastewater collection system via direct routes such roof downspouts, cross-connections with storm drains, foundation drains and maintenance hole covers.
Infiltration	Groundwater that enters through holes and cracks in maintenance holes, laterals and sewer pipes
IDF Curve	Intensity-Duration-Frequency Curve

TERM	DEFINITION
LPAT	Local Planning Appeal Tribunal
LPRCA	Long Point Region Conservation Authority
Maintenance Hole	Commonly called a manhole, it is an opening protected by a cast iron cover to access an underground sanitary sewer or storm sewer.
MOE	Ministry of the Environment, Conservation and Parks (Previously Ministry of the Environment/Ministry of the Environment and Climate Change) for the purposes of this document
OBC	Ontario Building Code
OLS	Ontario Land Surveyor
OPSD	Ontario Provincial Standard Drawings
OPSS	Ontario Provincial Standards and Specifications
PDC	Private Drain Connection
Plant	Infrastructure own and operated for electricity, gas, and telecommunications
Population Equivalent	Population per unit for determining sanitary sewer flows and water demands based on land use
Photometric Plan	Plan that measures light, in terms of its perceived brightness to the human eye, for streetlight placement.
Proponent	User of this manual, i.e., consulting engineer, contractor, developer, etc.
PVC	Polyvinyl Chloride
PVCO	Polyvinyl Chloride Biaxially-Oriented
Restraint (Joint)	Mechanical assembly unit that holds together a pipe at the connection point and utilizes the pipe itself to counter the thrust force from the pressurized water.

TERM	DEFINITION
Road Allowance	An allowance for a public road laid out by a land surveyor, including a road allowance shown on an original municipal survey and a road allowance included on a plan of subdivision.
R.O.W.	Right-of-way includes all areas of Tillsonburg that are the property of the Town.
Special Provision	Forms part of the Contract Document and shall be used for the supply and installation of works
Top Course	Hot Mixed Asphalt wearing course of any flexible or composite pavement
TAC	Transportation Association of Canada
WHMIS	Workplace Hazardous Materials Information System

1.4 Other Reference Documents

The Proponent shall design and construct the linear infrastructure in accordance with the latest version of this manual, industry standards, best practices, and related documents including but not limited to:

- Ontario Provincial Standard Specifications and Drawings
- Applicable Town of Tillsonburg By-laws
- Oxford County Design Guidelines
- Oxford County Official Plan
- Applicable Oxford County By-laws
- Accessibility for Ontarians with Disabilities Act (AODA)

Other reference documents related to various linear infrastructure components are identified in each section of the manual.

1.5 Permits and Approvals

The Proponent shall follow the requirements and seek approvals of other applicable authorities, agencies and Ministries including but not limited to the following:

- County of Oxford
- Long Point Region Conservation Authority
- Electrical Safety Authority
- Ministry of Environment, Conservation and Parks
- Ministry of Tourism, Culture and Sport
- Ministry of Natural Resources and Forestry
- Ministry of Transportation
- Fisheries and Oceans Canada

All required permits and approvals shall be in place prior to finalizing any development agreement.



**SUBDIVISION APPROVAL PROCESS
Operations Services
The Corporation of the Town of Tillsonburg
Development Guidelines and Design Criteria**

Section 2



Table of Contents

2	SUBDIVISION APPROVAL PROCESS	1
2.1	General Requirements	1
2.2	Draft Plan Approval	4
2.2.1	Pre-Consultation	4
2.2.2	Prepare the Application.....	5
2.2.3	Submission Requirements	5
2.2.4	Application Fee	7
2.2.5	Assess Application for Completeness.....	7
2.2.6	Return of Incomplete Draft Plan of Subdivision Application Packages.....	7
2.2.7	Notice of Application	7
2.2.8	Planning Evaluation Report	8
2.2.9	Public Meeting before Town Council.....	8
2.2.10	Statutory Public Meeting Before County Council	8
2.2.11	Notice of Decision	8
2.2.12	Design Studies/Engineering Drawings.....	8
2.3	Subdivision/Development Agreement	9
2.4	Other Approvals	9
2.5	Security Collection and Release	9
2.6	Pre-Construction Meeting.....	10
2.7	Construction and Inspection of the Works	10
2.8	Preliminary Acceptance of the Works.....	11
2.9	Maintenance of Works.....	12
2.10	Maintenance Securities	12
2.11	Final Acceptance of the Works.....	12
2.12	Assumptions of the Works.....	13

2 SUBDIVISION APPROVAL PROCESS

2.1 General Requirements

The purpose of this Section is to outline the submission process for subdivision development within the Town of Tillsonburg for the Proponent and its agent(s), Planner and Consulting Engineers required.

Plans of Subdivision are processed and approved under Section 51 of the Planning Act. Process and circulation requirements are identified in O. Reg. 544/06 of the Planning Act. The County of Oxford is the approval authority for draft plans of subdivision. Please refer to the Flow Chart on the next page for a brief overview of the approval process.

Draft Plan Approval Process

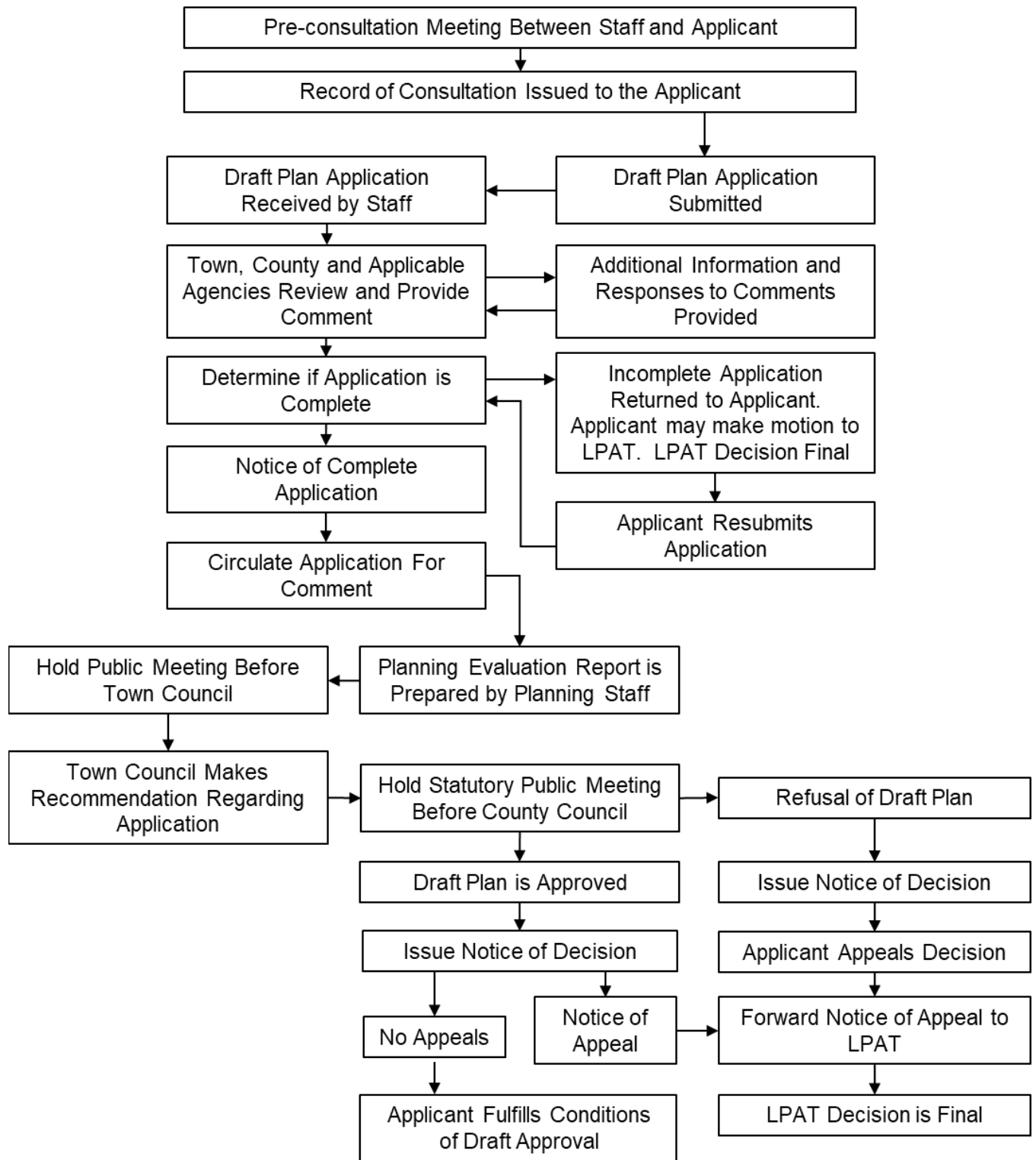

Engineering Design Approvals Process

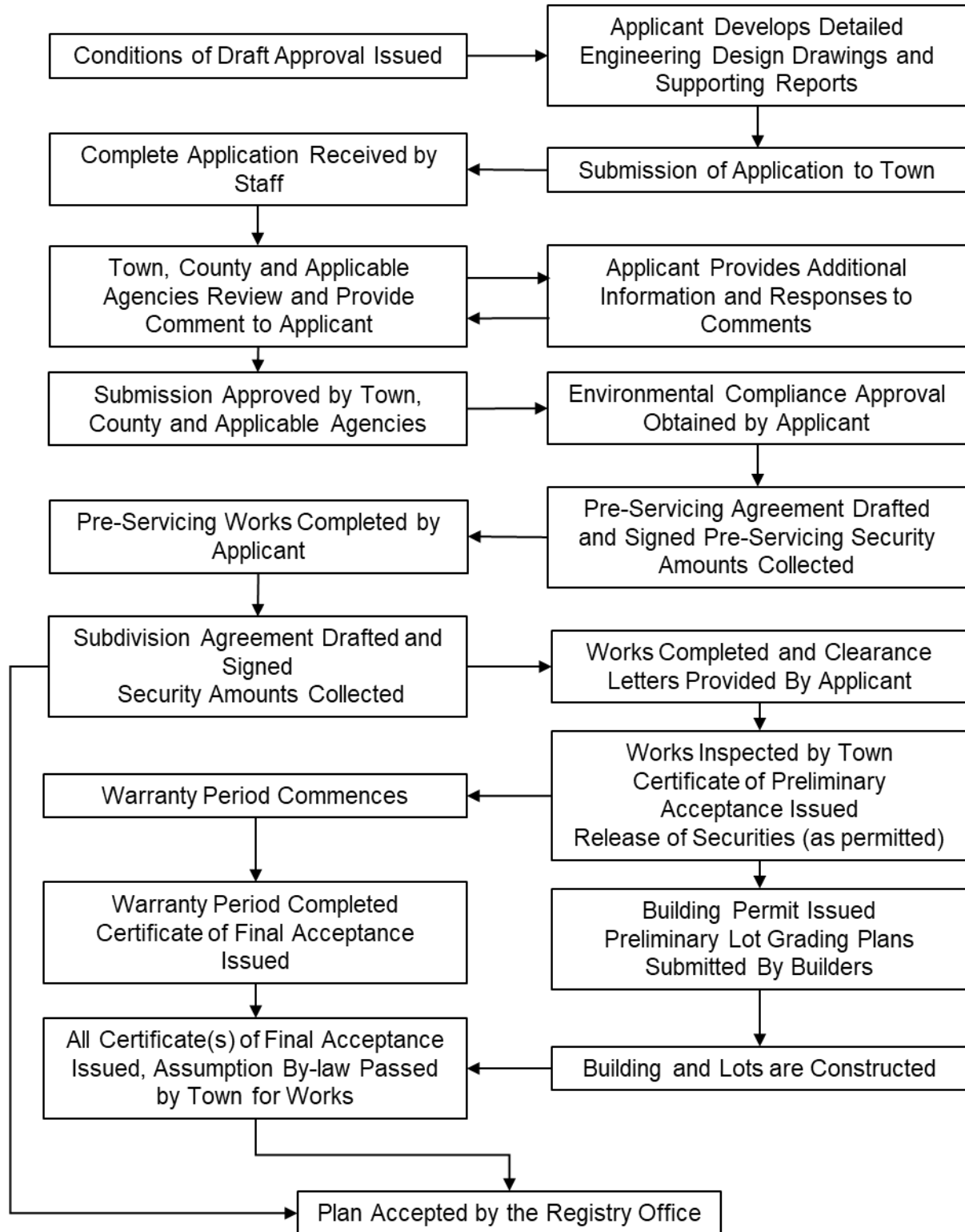

2.2 Draft Plan Approval

Planning services for the Town of Tillsonburg are provided by the Oxford County Community and Strategic Planning Office (CPO) including approvals for Draft Plan of subdivision. The Draft Approval Stage covers all activities from submission of a Draft Plan of Subdivision Application to Final Approval and registration of the Draft Plan. The following Guidelines will provide direction for the submission and processing of complete applications.

2.2.1 Pre-Consultation

Pre-consultation meetings are a mandatory part of the development review process for applications for Draft Plans of Subdivision. The Proponent meets with CPO staff/Development Planner to discuss the proposed application and to review zoning, servicing and characteristics of the site that are relevant to the development. This meeting will be initiated at the request of the Proponent at which time the Proponent shall submit to CPO a concept plan illustrating the configuration of the lots, frontages, road widths, open space etc.

Prior to the pre-consultation meeting the CPO staff/Development Planner will review the concept plan and confirm conformity with the Official Plan and Zoning By-law and identify any necessary amendments which may be required in addition to draft plan approval. Parkland dedication requirements will be identified as well as the preferred location for parks and open space requirements. CPO staff/Development Planner may consult with other County/Municipal divisions or agencies if there are concerns or constraints that are identified.

A meeting agenda will be prepared and distributed by the Development Planner and will be distributed to Town Staff at least 1 week before the meeting to ensure that the necessary staff are present.

During the pre-consultation meeting, application requirements will be discussed including:

- application forms,
- application fees,
- any supporting documents required for the official plan and zoning by-law amendment and draft plan of subdivision,
- public consultation strategy requirements and checklist,
- review of timelines and potential scheduling for notices and public meetings.

Although the requirements for a complete application will be identified during the pre-consultation meeting it should be recognized that as the approval process proceeds other items, not noted at the pre-consultation meeting, may be requested as the design progresses and more information becomes available.

2.2.1.1 Record of Consultation

A concise record of the requirements for draft plan approval as identified by planning and engineering at the pre-consultation meeting will be completed by the Consultant. The requirements identified in the

Record of Consultation will form the contents of a complete subdivision application submission. The requirements identified in the Record of Consultation will allow the Conditions of Draft Approval to be crafted during the draft approval stage. It is anticipated that the Record of Consultation will be distributed no later than 7 business days after the pre-consultation meeting.

2.2.1.2 Consult Other Agencies

The application process can involve consultation with several outside agencies. In some cases, the Proponent may be required to consult with one or more of these agencies prior to the submission of the application to determine if any additional items will be required. Fees associated with those consultations are not covered by the fee submitted to the CPO for draft plan approval.

2.2.2 Prepare the Application

The Proponent has sole responsibility for submitting a complete application and may be required to prepare drawings or studies depending on feedback from the pre-consultation meeting and consultation with other agencies. The complete application including supporting material, declarations and the appropriate fees are to be submitted to CPO by mail or in person. The application shall have regard for matters of Provincial interest and shall be consistent with the Provincial Policy Statements issued under Section 3 of the Planning Act. Section 51(24) of the Planning Act requires that when a draft plan of subdivision is considered, it must have regard for health, safety, convenience and welfare of the present and future inhabitants of the municipality.

If it has been determined during pre-consultation that a zoning by-law amendment and/or an official plan amendment is required, submission of the zoning by-law amendment application and official plan amendment application may take place at any time prior to the granting of final plan approval, however it is recommended that the necessary zoning by-law amendment application and official plan amendment application be filed with the local municipality at the same time as the plan of subdivision application so that a combined public meeting can be held.

2.2.3 Submission Requirements

All applications for draft plan approval must include the following:

- Six (6) full size folded copies of the draft plan drawn to scale, with boundaries certified by an Ontario Land Surveyor
- Two (2) reduced copy no larger than 11" x 17" and a digital file in pdf and an e-transmit CAD file format are required

All draft plans must include all items as required under Section 51(17) of The Planning Act including:

- the boundaries of the proposed subdivision certified by an Ontario Land Surveyor, Ontario land surveyor's name, signature and date of signature
- map scale, legend, north marker
- name of person or firm who prepared the plan, date plan prepared and dates of any revisions

- the location, widths and names of the proposed highways within the proposed subdivision and of existing highways on which the proposed subdivision abuts
- dimensions and layout of the proposed roads, lots and blocks, including walkways, school sites and park blocks (if any)
- on a small key plan at a scale of not less than 1cm:100m,- all of the adjacent land to the proposed subdivision that is owned by the Proponent or in which the Proponent has an interest, and every subdivision adjacent to the proposed subdivision and the relationship of the boundaries of the land to be subdivided to the boundaries of the municipal lot or other original grant of which the land forms the whole or part
- the purpose for which the proposed lots are to be used
- the existing land use on the site and on all adjacent lands
- the approximate dimensions and layout of proposed lots
- natural and artificial features within or adjacent to the land proposed to be subdivided including:
 - existing buildings and structures to be retained or demolished
 - active or inactive railways, rail rights-of-way
 - highways and other roads - existing, public/private, open/closed location, width, and proposed generic street labels (i.e. Street A, Street B) with a separate list of proposed street names
 - watercourses (lakes, streams, ponds, wetlands, etc.)
 - flood plains/flood elevations, flood lines, fill lines, top of slopelines
 - woodland
 - significant plant and wildlife habitat (including ESA's & ANSI's)
 - drainage courses, retention ponds (natural or man-made)
 - archaeological or historic features
- the municipal services available or to be available to the land proposed to be subdivided
- waterlines and sewer
- main hydro lines
- the nature and porosity of the soil
- existing contours (Site surveys are not to exceed 5 years) or elevations as may be required to determine the grade of the highways and drainage
- the availability and nature of domestic water supplies
- the nature and extent of any restrictive covenants or easements affecting the site
- lot and concession/registered plan number/street address
- Owner's name(s), signature(s) and date of signature(s) or Authorized Individual
- all measurements, scales, etc. must be in metric units

2.2.4 Application Fee

The application must be accompanied by the application fee and any required peer review deposit in accordance with Schedule "A", County of Oxford By-law No. 4889, as amended, made payable to the 'County of Oxford. The application fee is established by County Council under Section 69 of the Planning Act to recover the administrative costs involved in processing applications.

Additional fees, as set out in the County of Oxford By-law No. 4889, as amended, may be required to review supporting reports and studies. The Proponent shall submit a deposit, as determined by the County, based on the estimated cost of peer review for studies submitted in support of the application. Any amount in excess of the actual cost of a peer review shall be reimbursed.

2.2.5 Assess Application for Completeness

From the date the application is submitted, the approval authority has up to 30 days to assess the submission for completeness based on consistency with Planning Act requirements and the Record of Consultation. They will then notify the Proponent of the decision in writing (Letter of Complete Application). If the application is deemed complete, it is accepted for processing and review. Completeness at this point is for receipt of the application and does not imply or convey acceptance of the technical information provided or any associated recommendations. Applications accepted for review are required to receive an approval authority decision within 180 days of submission of the application package.

2.2.6 Return of Incomplete Draft Plan of Subdivision Application Packages

Applications deemed incomplete by the approval authority are returned to the Proponent in full including a written response identifying the outstanding requirements. If the Proponent disagrees with the approval authority's assessment of the completeness of the application, the Proponent may contact CPO. If agreement is not reached, the Planning Act provides 30 days for the Proponent to make a motion to the Local Planning Appeal Tribunal (LPAT) for a determination on the matter and the decision of LPAT is final.

When all required information has been submitted, a Letter of Complete Application will be issued. The 180-day decision period will begin when packages are returned for reconsideration.

2.2.7 Notice of Application

The approval authority is required to provide a Notice of Complete Application within 15 days after the Letter of Complete Application has been issued to the Proponent. The application is circulated to the public, agencies and municipal departments. The public circulation applies to every property owner within 120 metres of the subject land and to every person and public body that has provided a written request for such notice. Any member of the public, agency or municipal body may make written submissions to the approval authority before its decision.

2.2.8 Planning Evaluation Report

The Development Planner will undertake an evaluation of the application using the relevant planning policy documents and Town Zoning By-law, taking into account oral and written comments received. The Development Planner will prepare a Report on the development application(s) which will establish staffs position on the application(s), either approval or refusal. If the Planning Evaluation Report recommends approval it will include conditions that are to be satisfied before the issuance of Draft Plan Approval. The report will address all comments and positions received from the public and will include all comments received from internal divisions and external commenting agencies.

2.2.9 Public Meeting before Town Council

A meeting will be held before Town Council on the second or fourth Monday of the month to present the application to the public, to hear comments and concerns, to provide technical clarification and to explain the development review process. The Planning Evaluation Report prepared by Planning Staff will be made available on the Towns Website on the Friday before the public meeting. At this meeting, the Proponent and or the Proponent's agent(s) may present details about the proposed development. Town Council will then make a recommendation as to the appropriateness of the development. If Town Council recommends draft plan approval, the application is forwarded to the County of Oxford for consideration.

2.2.10 Statutory Public Meeting Before County Council

Plan of Subdivision Applications require a statutory public meeting in accordance with the Planning Act. The statutory public meeting will be held on the second or fourth Wednesday of every month. Notice of any statutory public meeting will be given at least 20 days prior to the date of the meeting. The meeting agenda and the Planning Evaluation Report will be made available on the County's website on the Friday before the meeting. Any person in attendance at the public meeting shall be afforded the opportunity to make representations regarding the proposed development application(s). County Council exercises the final approval authority responsibility.

2.2.11 Notice of Decision

The Proponent, owners and any person or public body that requested to be notified will be notified of the decision within 15 days. After County Council has granted draft plan approval the County's decision is subject to a 20-day appeal period from the date of the Notice of Decision. If no appeals are received after the Notice of Draft Approval has been sent, the owner must satisfy all the conditions of draft plan approval.

2.2.12 Design Studies/Engineering Drawings

Following Draft Approval, the Proponent shall compile design studies and drawing submission package including all required and requested supporting studies/investigation as identified in the conditions of draft plan approval and Section 3 – Subdivision Submission Requirements of this document.

The requirements of various studies, investigations and drawings for this process can be found in Section 3 of this document.

Engineering shall circulate the completed development application to all departments as required to solicit comment and feedback on the proposed design. The Town/County will review the application and provide a Summary Comment Letter and/or drawings for the Proponent to address and provide justification and/or comment.

The Proponent shall address all the comments and issues identified from the Town/County review and provide a resubmission of the complete development application to the engineering department and associated fees as per the Town's and County's Rates & Fees By-law, as amended

2.3 Subdivision/Development Agreement

Once all departments have been satisfied with the development submission, a draft pre-servicing or draft subdivision agreement will be circulated to relevant agencies and departments prior to finalization of the respective agreement(s), for their review and comment. Once all parties are satisfied with the contents of the agreement(s), it may be prepared for final signature.

2.4 Other Approvals

The Proponent is solely responsible for obtaining all required approvals and clearances prior to the finalization of the pre-servicing or subdivision agreement. These approvals may include, but are not limited to, the following:

- All Ministry of the Environment, Conservation and Parks – Environmental Compliance Approvals as noted during pre-consultation
- County of Oxford
- Ministry of Transportation
- Ministry of Natural Resources and Forestry
- Long Point Region Conservation Authority
- Fisheries and Oceans Canada

2.5 Security Collection and Release

Upon execution of the pre-servicing and/or subdivision agreement, the Town of Tillsonburg will collect full security amounts for all Municipal and R.O.W. works including 1.76% applicable HST.

Suitable forms of the security deposit are:

- An irrevocable Letter of Credit satisfactory to the Town from any financial institution
- Cash
- Certified cheque

- Development Bond, in a manner satisfactory to the Town

Irrespective of the manner in which the amount of security was calculated, the security is deposited to secure all obligations of the Proponent and the security may be used by the Town to complete any aspect of the Works, pay for any works completed, or fulfill any other obligation of the development agreement that the Proponent has failed to complete.

As work progresses and upon issuance of certificates of acceptance by the Town, security amounts may be reduced through the submission of the most current version of the Security Reduction Request Form that can be obtained from the Town of Tillsonburg – Engineering Services. The Town will retain an appropriate amount of securities at all times to ensure completion of all outstanding Works or obligations required of the Proponent. A minimum of \$25,000 will be retained until the Assumption By-Law is in place.

2.6 Pre-Construction Meeting

Once all the pre-requisites for commencement of construction have been met, the Proponent shall request a pre-construction meeting with the Town of Tillsonburg, Proponent, Consulting Engineer and Selected Contractor be arranged a minimum of ten (10) working days prior to construction.

The Proponent will be responsible for organizing the attendance of any utility companies, other agencies and staff who are perceived to have an interest in the construction.

During the meeting, the Proponent shall provide the Town an approximate schedule of construction, list of materials, and mix designs to be used in the construction of the subdivision for review and approval of the Town.

The Consulting Engineer shall prepare meeting minutes to be circulated to all parties after being reviewed and approved by the Town.

2.7 Construction and Inspection of the Works

All works to be constructed shall be inspected and tested under the direction of the Consulting Engineer.

The Proponent shall be responsible for providing full time site inspection for all municipal and R.O.W. works occurring within the subdivision. The Town may provide independent periodic site inspection to confirm the contract documents and approvals are being adhered to.

At the sole discretion of the Town or County, the Town and County shall reserve the right to have inspectors/consultants employed to review all the approved plans and specifications and observe the construction and installation of the Works and Services at any time. The cost of this inspection will be the sole responsibility of the Proponent.

The Consulting Engineer shall notify the Town of Tillsonburg regarding the timing for all watermain work within the R.O.W. The Town shall have full time inspection on-site during all watermain work to confirm compliance to applicable standards.

2.8 Preliminary Acceptance of the Works

Upon completion of all Works by the Proponent and submission of all compliance letters and clearances to the Town of Tillsonburg for all underground and surface works from the Consulting Engineer, the Town Engineering Department will prepare a Preliminary Certificate of Acceptance to commence the respective maintenance period(s) and permit request for security reduction(s) by the Proponent.

The Proponent may be required to provide the following information:

- Maintenance securities as determined by the Town
- Statutory Declaration for all accounts
- Watermain testing result for commissioning
- Daily construction diary
- Proof of the MOE Environmental Compliance Approvals (ECA)
- Proof of insurance as determined by the Town
- Proof of the registration to title of the Plan of Subdivision, subdivision agreement and associated schedules
- Certification from an Ontario Land Surveyor (OLS) that all survey monuments and iron bars are installed and located at grade
- Copies of the test results for:
 - Concrete sidewalk
 - Curb and gutter
 - Base course asphalt
 - Surface course asphalt
 - Geotechnical testing
 - Sieve analysis and compaction testing for sewer and watermain bedding material
 - Sieve analysis and compaction testing of road subgrade and granular base courses
- A certification letter from the Consulting Engineer certifying:
 - All Services and Works have been constructed in conformance with the approved drawings
 - Rough grading has been completed to provide a proper outlet for the major design storm
 - All hydrant testing has been completed in the presence of a licensed Operator from the County and/or designated service provider
 - All sanitary and storm manholes and catch basins have been flushed and cleaned along with a CCTV inspection of the sanitary and storm systems

The final course surface asphalt is not placed for a minimum of two (2) years after Preliminary Acceptance.

At the sole discretion of the Town's Director of Operations and Development, separate certificates of Preliminary Acceptance may be issued for below ground (including curb and base course asphalt) and above ground works or stormwater management facilities.

2.9 Maintenance of Works

The Proponent shall be responsible for the repair and maintenance of all works and services constructed, installed or provided by the Proponent for a minimum period of two (2) years from the date of the associated Preliminary Certificate of Acceptance. An additional one (1) year maintenance period shall be required for the final course of asphalt commencing from the date the Preliminary Certificate of Acceptance is provided for that specific work.

The Proponent shall complete any maintenance or repair work within seventy-two (72) hours after receiving a written request from the Town. Should the Proponent fail to complete the works within the required seventy-two (72) hours, the Town may draw from the securities posted to complete the work.

For stormwater management facilities, the Proponent shall undertake final cleaning and dredging of the facility once 90% of the contributing lots have been completed, as confirmed by the Town.

2.10 Maintenance Securities

The Proponent will be required to post maintenance securities for ten percent (10%) of the total estimated cost of the works and services with an additional fifteen percent (15%) for the base and surface course asphalt and curb and gutter works plus full securities for the final cleaning and dredging of all stormwater management facilities.

2.11 Final Acceptance of the Works

Upon the conclusion of the maintenance period, final inspections will be completed with the Town of Tillsonburg Staff, the Consulting Engineer, and other Applicable parties to confirm and verify the warranty/maintenance work required and final state of the project.

The Proponent may be required to provide the following information:

- Statutory Declaration for all accounts
- Proof of the MOE Environmental Compliance Approvals (ECA)
- Proof of insurance as determined by the Town
- Certificate from the Electrical Safety Authority certifying the streetlighting system
- Proof of the registration to title of the Plan of Subdivision, subdivision agreement and associated schedules
- Certification from an Ontario Land Surveyor (OLS) that all survey monuments and iron bars are installed and located at grade

- Confirmation from the Town that any emergency repairs that may have been required are fully paid for by the Proponent
- A certification letter from the Consulting Engineer certifying:
 - All Services and Works have been constructed in conformance with the approved drawings
 - Rough grading has been completed to provide a proper outlet for the major design storm
 - All hydrant testing has been completed in the presence of a licensed Operator from the County and/or designated service provider
 - All sanitary and storm manholes and catch basins have been flushed and cleaned along with a CCTV inspection of the sanitary and storm systems
 - Retaining wall structures are structurally sound and were constructed as per the approved design drawings and applicable standards
- Final “as-constructed” drawings on original mylar transparencies and electronically on a USB 2.0 drive in AutoCAD or DXF format.
- Record Forms (provided by the Town) indicating the swing ties to all plant features.

Once the Town deems that all deficiencies have been rectified and all conditions of the subdivision agreement have been met, the Town will provide a Certificate of Final Acceptance at which time the associated maintenance securities can be released by the Town. At the sole discretion of the Town’s Director of Operations, separate Certificates of Final Acceptance may be issued for below ground works (including curb and base course asphalt) and above ground works or stormwater management facilities.

2.12 Assumptions of the Works

The Town will assume the works once all Certificates of Final Acceptance have been issued by the Town and the Town has approved and passed an Assumption By-law.

Once the water distribution and sanitary collection systems have been installed to the satisfaction of the Town/County, the water distribution and sanitary collection systems shall be assumed and operated by the County and/or designated service provider.

Once all repairs have been completed and the Proponent has complied with all terms and conditions of the subdivision agreement, the Town Director of Operations shall submit a written report to Town Council outlining compliance with the approved drawings and subdivision agreement.

The works shall not be construed as assumed by the Town until the Assumption By-law is passed by Town Council.



SUBDIVISION SUBMISSION REQUIREMENTS
Operations Services
The Corporation of the Town of Tillsonburg
Development Guidelines and Design Criteria

Section 3

Table of Contents

3	SUBDIVISION SUBMISSION REQUIREMENTS	1
3.1	General Requirements.....	1
3.1.1	Tillsonburg Hydro Inc	1
3.1.2	Water Distribution System	1
3.1.3	Utilities	1
3.1.4	Easements	1
3.1.5	Geotechnical Report	2
3.1.6	Excess Soil Management Plan	2
3.1.7	Functional Servicing Report	2
3.2	Submission of Servicing Drawings	3
3.2.1	First Submission.....	3
3.2.2	Subsequent Submissions	4
3.2.3	Ministry of the Environment, Conservation and Parks Applications	4
3.2.4	Other Approvals	4
3.3	Drawing Format and Requirements.....	4
3.3.1	Calculate Survey Plan and Draft Plan.....	5
3.3.2	Cover Sheet	5
3.3.3	General Plan of Services.....	5
3.3.4	Sanitary Sewer Design and Area Plan.....	5
3.3.5	Storm Sewer Design and Area Plan	6
3.3.6	Plan and Profile Drawings	7
3.3.7	Lot Grading Drawings.....	8
3.3.8	Storm Water Management Drawings	9
3.3.9	Photometric Plan Submission	10
3.3.10	Composite Utility Plan	11
3.3.11	Landscape Plan	11
3.4	“As-Constructed” Drawings	11
3.4.1	“As-Constructed” Field Survey.....	12
3.4.2	Drawings Revisions.....	12
3.4.3	Submission of “As-Constructed” Drawings	12
3.4.4	GIS Information	13
3.4.5	Asset Management Information	13



SUBDIVISION SUBMISSION REQUIREMENTS
Operations Services
The Corporation of the Town of Tillsonburg
Development Guidelines and Design Criteria

Appendices

Section 3 - Appendix "3-1" Asset Management Plan Data Table Example

3 SUBDIVISION SUBMISSION REQUIREMENTS

3.1 General Requirements

The purpose of this section is to provide general submission requirements and design guidelines for the developer and its engineering consultants required for project acceptance by Operations Services of the Town of Tillsonburg.

3.1.1 Tillsonburg Hydro Inc.

Tillsonburg Hydro Inc. is responsible for the approval of the electrical distribution system and services installed within all road allowances and associated registered easements within the Town of Tillsonburg.

All hydro servicing is to be designed by an Electrical Consultant and installed within the road allowance or applicable easement in accordance with the most recent requirements and specifications of the Town and Tillsonburg Hydro Inc. The developer will be required to enter into a separate Connection Agreement for the hydro installation with Tillsonburg Hydro Inc. All inquiries regarding hydro servicing shall be directed to Tillsonburg Hydro Inc.

3.1.2 Water Distribution System

The Consultant shall submit a general plan of the proposed water distribution system indicating the main size, material, location of hydrants, valves, blowoffs and other appurtenances, including sidewalks prior to the preparation of the plan and profile drawings to the Town for review and approval. If hydraulic modelling is required to verify watermain sizing, the County of Oxford will provide water pressures and flows at locations specified by the consulting engineer for their design.

3.1.3 Utilities

The Developer shall arrange for streetlight, servicing cables, telecommunication cables and natural gas to be installed underground, all to the satisfaction of the respective Operating Authority and the Town of Tillsonburg.

A street lighting system providing illumination in accordance with the requirements of Section 9 - Utilities and installed by the Developer to the current standards of the Town. A digital file in AutoCAD Format shall be submitted to the Town.

3.1.4 Easements

The Developer shall provide easements of sufficient width for all municipal services and utilities that cross private property. Easement width shall be determined based on minimum trench width, side slopes and soil types as per Ontario Health and Safety Act. The developer shall register all

easements at no cost to the Town of Tillsonburg. Preliminary reference plans shall be submitted to the Town of Tillsonburg for approval.

3.1.5 Geotechnical Report

A soils investigation and report from a qualified geotechnical engineer is required to be provided with the first submission of engineering drawings, which will address the following:

- soil types to be encountered during construction and building
- information on water table levels and impacts on road structure
- recommendations regarding trench backfill and bedding material
- road structure design
- recommended stable trench construction and building foundation support

3.1.6 Excess Soil Management Plan

An Excess Soil Management Plan shall be prepared by a Qualified Person, as defined by Ontario Regulation 153/04, for proposed developments that require excess soil to be removed from site and meets the criteria of current Ontario regulations. The purpose of the report is to characterize the quality of the excess soil and generate a management plan that is in compliance with the current Ontario regulations for excess soil management.

The Plan shall be prepared as per the MOE's "Management of Excess Soil – A Guide for Best Management Practices" and shall comply with the current regulatory implementation schedule as put forth by the MOE.

The Excess Soil Management Plan shall be submitted to the Town of Tillsonburg for approval. If deemed appropriate by the Town, the Town may appoint a qualified third-party reviewer to review the plan for compliance to the current regulatory obligations. The owner shall be responsible for the cost of the third-party reviewer.

The Owner will be responsible for O.Reg 406/19 ON-SITE AND EXCESS SOIL MANAGEMENT

3.1.7 Functional Servicing Report

A functional servicing report (FSR) describes the layout of the development and required infrastructure including detailed engineering to demonstrate the feasibility of the services requiring approval from the Town and County. The FSR ensures that the proposed development can be serviced for its intended use, and that all on-site and off-site servicing requirements are identified.

In cases where the subdivision development under consideration forms part of a larger area set aside for future development, the FSR shall be a definite requirement in order to confirm that the servicing design does not limit the future development. The FSR shall be a definite requirement, when a subdivision is being phased and the engineering design is being undertaken for each phase separately. The FSR shall be signed and sealed by a professional engineer.

A FSR shall include, but will not necessarily be limited to the following considerations:

- Major roadway alignments, cross-sections and intersections
- Watercourse improvement and channelization
- Railway crossings as applicable
- Major trunk sewers and watermains
- Stormwater management facilities
- Storm drainage systems
- Sanitary drainage systems
- Water distribution systems
- Utility servicing
- Site grading design
- Pumping station locations (if applicable)

3.2 Submission of Servicing Drawings

3.2.1 First Submission

The first submission of servicing drawings and design calculations for a proposed development shall contain the following information:

- three copies of the proposed Draft Plan
- three copies of the Calculated Survey Plan
- three copies of the General Plan of Services
- three copies of the Sanitary Drainage Areas and Design Sheet
- three copies of the Storm Drainage Areas and Design Sheet
- three copies of the External Drainage Areas (if required)
- three copies of the Plan and Profiles
- three copies of the Lot Grading & Erosion Control Plans
- three copies of the Storm Water Management Facility (if required)
- three copies of the Photometrics Plan
- three copies of the Composite Utility Plan
- three copies of the Landscape Plan
- three copies of the Details and Notes
- three copies of all External Works (if required)

- three copies of the geotechnical report, storm water management facility functional report, slope stability report, all reports required as noted in the conditions of draft plan approval
- three copies hydraulic water analysis report and drawing (if required)
- Digital copies in PDF format of all requirement documentation.

The above information will be reviewed by the Town of Tillsonburg and a summary comment letter will be provided to the Consultant Engineer for review and responses.

3.2.2 Subsequent Submissions

Subsequent submissions of applicable drawings and calculations shall be made until the engineering drawings, design, and calculations are acceptable to the Town of Tillsonburg. Once approved two copies of all supporting information shall be forwarded to the Town of Tillsonburg Operations Services for their records.

Fees for additional submissions will be assessed based on the Town of Tillsonburg Rates and Fees Bylaw (as amended).

3.2.3 Ministry of the Environment, Conservation and Parks Applications

Once the engineering design, drawings, and calculations have been approved by the Town of Tillsonburg, three copies of Ministry of the Environment, Conservation and Parks Applications completed by the Developer / Consulting Engineer shall be forwarded to the Town of Tillsonburg and the County of Oxford for signing.

A copy of the MOE Form 1 for any watermain systems shall be forwarded to the Town of Tillsonburg for their records.

3.2.4 Other Approvals

The developer/engineering consultant shall be required to make all submissions and representations necessary to obtain approval from all authorities affected by the development. These may include but are not limited to the following: County of Oxford, Ministry of Transportation, Ministry of Natural Resources and Forestry, Fire Department, Parks Division, and Long Point Region Conservation Authority. The Town of Tillsonburg shall be kept informed of the progress of these approvals by copies of all correspondence. All approvals shall be in place prior to the execution of any Development Agreement.

3.3 Drawing Format and Requirements

The following information is required to be submitted for approval of servicing drawings.

3.3.1 Calculate Survey Plan and Draft Plan

A calculated plan completed by an Ontario Land Surveyor must be completed and submitted with the first submission of servicing drawings. The calculated plan shall be drawn in metric units. The approved draft plan shall also be provided with the first submission of servicing drawings.

3.3.2 Cover Sheet

The cover sheet shall include the Name of Development, Developers Name, List of Drawings, Town's Logo and Key Plan showing location of project.

3.3.3 General Plan of Services

The General Plan of Services shall include sanitary sewers, storm sewers, watermains, storm water management facilities, and all easements. Lot numbering and lot fabric shall match that of the draft plan. The General Plan of Services shall show all proposed and existing services required for servicing the proposed development and serves as a "key" plan for the remainder of the drawing set. In addition, the General Plan of Services shall satisfy the following requirements:

- scale shall be 1:1000
- metric A1 sheet
- north arrow
- delineate limits of subdivision and/or phasing
- proposed and existing lot/block numbers
- proposed and existing street names
- proposed and existing sanitary and storm sewers
- label all proposed and existing sewer lengths (one decimal), size, manholes, catch basins, ditch inlet catch basins, grades (two decimals) and direction of flow
- all proposed and existing watermains, size, material, hydrants, valves and fittings
- legend
- at least three geodetic benchmarks
- reference drawing numbers for plan and profiles
- all drawings to be stamped, signed and dated by a professional engineer

3.3.4 Sanitary Sewer Design and Area Plan

The Sanitary Sewage Design and Area Plan shall include all information necessary to complete a thorough review of the design. All external areas shall be shown on the drawing. If the external areas are too large to be accommodated, a separate drawing for the external sanitary areas shall be included in the set. Drainage areas shall be delineated on a lot line by lot line and manhole to manhole basis and shall include drainage area numbers, areas in hectares and population or non-

residential zoning class. A design sheet shall also be included on the drawing. If the design sheet cannot be accommodated on the drainage area plans, the sanitary design sheet can be shown on its own drawing or included with the storm design sheet on its own drawing. In addition, the Sanitary Sewage Design and Area Plan shall satisfy the following requirements:

- scale shall be 1:1000
- metric A1 sheet
- north arrow
- delineate limits of subdivision and/or phasing
- proposed and existing lot/block numbers
- easements, municipal numbers of existing lots, road widenings, identify semi- detached lots
- proposed and existing street names
- proposed and existing sanitary sewers
- label all proposed and existing sewer lengths (one decimal), size, manholes, grades (two decimals) and direction of flow
- delineate all sanitary drainage areas by lot line and on a manhole by manhole basis, show drainage area number, area in hectares, and population and/or non-residential zoning class for each catchment area
- design sheet to be shown on drawing
- legend
- all drawings to be stamped, signed and dated by a professional engineer

3.3.5 Storm Sewer Design and Area Plan

The Storm Sewer Design and Area Plan shall include all information necessary to complete a thorough review of the design. All external areas shall be shown on the drawing. If the external areas are too large to be accommodated, a separate drawing for the external storm areas shall be included in the set. Drainage areas shall be delineated on an actual contributing drainage area and manhole to manhole basis and shall include drainage area numbers, areas in hectares and runoff coefficients. A design sheet shall also be included on the drawing. If the design sheet cannot be accommodated on the drainage area plans, the storm design sheet can be shown on its own drawing or included with the sanitary design sheet on its own drawing. In addition, the Storm Sewer Design and Area Plan shall satisfy the following requirements:

- scale shall be 1:1000
- metric A1 sheet
- north arrow
- delineate limits of subdivision and/or phasing
- proposed and existing lot/block numbers

- lot/block dimensions, easements, municipal numbers of existing lots, road widenings, identify semi- detached lots
- proposed and existing street names
- proposed and existing storm sewers, ditches and watercourses
- label all proposed and existing sewer lengths (one decimal), size, manholes, catchbasins, ditch inlet catchbasins, grades (two decimals) and direction of flow
- delineate all storm drainage areas by the actual catchment area and a structure by structure basis, show drainage area number, area in hectares, runoff coefficient for each catchment area
- design sheet to be shown on drawing
- legend
- all drawings to be stamped, signed and dated by a professional engineer
- overland flow

3.3.6 Plan and Profile Drawings

Plan and Profile drawings of each street and easement shall include all information necessary to construct the proposed works. In addition, Plan and Profile drawings shall satisfy the following requirements:

- scale shall be horizontal 1:500, vertical 1:50
- metric A1 sheet
- north arrow
- delineate limits of subdivision and/or phasing
- proposed and existing lot/block numbers
- lot/block dimensions, easements, municipal numbers of existing lots, road widenings, horizontal curve data, vertical curve data, S.I.B. locations, identify semi-detached lots and all pertinent survey data
- proposed and existing street names
- proposed and existing sanitary and storm sewers and watermain
- label all proposed and existing manholes, catch basins, ditch inlet catch basins, hydrants, valves, etc
- for storm, sanitary and watermain label pipe material, size, bedding type, inverts or C/L of watermain, length (one decimal) and grade (two decimals)
- elevations for top of base flange of hydrants, catchbasin and ditch inlet frame and grates
- all proposed and existing surface features such as curb and gutter, sidewalk, asphalt roadways, ditches, swales, existing buildings, etc
- all existing utilities abutting proposed development shall be shown

- all landscaping shall be shown as per the landscape plan
- show elevations and chainages at Beginning of Curves (B.C.'s), End of Curves (E.C.'s), project limits, centerline intersections, 20m intervals, and breakpoints
- show private drain connections, and water services
- show existing and future profiles for a distance of 60m from project limits
- plan and profiles of rear yard catchbasins, walkways, and servicing easements are required
- reference drawing numbers for adjoining plan and profiles
- borehole information in plan and profile
- dimensions for road width, manholes, catch basins, sidewalks, watermain, etc
- show all existing features i.e. trees, mailboxes, creeks, ponds, etc
- all drawings to be stamped, signed and dated by a professional engineer

3.3.7 Lot Grading Drawings

The Lot Grading Drawings shall include all information and grades necessary to ensure proper grading of the proposed lots as well as ensuring drainage compatibility with existing lands, which abut the proposed development, i.e. not restricted or inundated due to the new development. The drawings should also include overland flow arrows which delineate the proposed flow route of a major storm. Erosion and sediment control measures and notes can be included on the Lot Grading Drawings. In addition, Lot Grading Drawings shall satisfy the following requirements:

- scale shall be 1:500
- metric A1 sheet
- north arrow
- delineate limits of subdivision and/or phasing
- proposed and existing lot/block numbers, registered plan numbers etc
- lot/block dimensions, easements, municipal numbers of existing lots, road widenings, S.I.B. locations, identify semi-detached lots and all pertinent survey data
- at least two geodetic benchmarks
- proposed and existing street names
- all proposed and existing surface features such as curb and gutter, sidewalk, asphalt roadways, driveways, ditches, swales, existing buildings, hydrants, valves, manholes, catch basins, ditch inlet catch basins, etc
- all existing surface utilities abutting proposed development shall be shown
- show proposed elevations at B.C.'s, E.C.'s, project limits, centreline intersections, 30m intervals, lot corners, building setback line, and breakpoints

- show proposed maximum building envelopes, elevations at all lot and block corners, proposed elevations at the front and rear of all buildings, proposed finished floor or top of foundation elevations for all lots as well as break point elevations along rear and side yard swales and accompanying slopes along each side yard / swale
- provide drainage arrows for overland surface flow
- provide drainage arrows for major overland flow due to 100-year storm flooding
- show existing contours at 0.5m interval and existing spot elevations around perimeter of development
- show a minimum of 30m of existing contours and features around perimeter of development
- show all existing features i.e. trees, mailboxes, creeks, ponds, etc
- all drawings to be stamped, signed and dated by a professional engineer

3.3.8 Storm Water Management Drawings

The Storm Water Management Drawings shall include all information necessary to construct the stormwater management facility so it will function as per design. Details for the Storm drainage area shall be included. Details for inlet and outlet structures shall be included on this sheet. Cross sections along the length and perpendicular to the facility shall be included. Ground cover and erosion protection to be detailed on this drawing. In addition, Stormwater Management Drawings shall satisfy the following requirements:

- scale shall be 1:500 or larger.(i.e. 1:250)
- metric A1 sheet
- north arrow
- delineate limits of subdivision and/or phasing
- proposed and existing lot/block numbers
- lot/block dimensions, easements, municipal numbers of existing lots, road widenings
- at least two geodetic benchmarks
- proposed and existing street names
- all proposed and existing features such as curb and gutter, sidewalk, asphalt roadways, ditches, swales, existing buildings, hydrants, valves, manholes, catch basins, ditch inlet catch basins, etc
- all existing surface utilities abutting proposed development shall be shown
- show a minimum of 30m of existing contours and features around perimeter of development
- show all existing features i.e. trees, mailboxes, creeks, ponds, etc.
- show all related design features, structures, weirs and grades / elevations, etc.

- show maintenance access
- Overland Flow route
- all drawings to be stamped, signed and dated by a professional engineer
- details and notes

The Details and Notes drawings shall contain specific details and notes needed to construct the proposed works. Notes shall include standard specifications relating to general construction or specific items. There shall be a typical cross-section through a R.O.W. showing pavement width, road structure, general sewer locations, watermain and utility locations. In addition, the Details and Notes drawings shall satisfy the following requirements:

- details to scale if possible
- metric A1 sheet
- standard general construction notes
- sewer and watermain construction notes
- list of standard OPSD and Town of Tillsonburg standards to be used on project
- typical cross section showing sewer and watermain locations, R.O.W. dimensions, pavement structure, trenching details based on soil type, curb and gutter type, sidewalk location, subdrains, trench backfill details, and proposed utility locations
- miscellaneous details and sections required for construction of development
- benchmark list (at least two)
- all drawings to be stamped, signed and dated by a professional engineer

3.3.9 Photometric Plan Submission

The Photometric Plan shall be prepared and should reference 'LUX' units of measure for information purposes. The Plan should include a point-by-point photometric grid superimposed over the site that clearly indicates the proposed site lighting levels.

Other plan requirements include:

- a fixture legend indicating the fixture details
- arm length and height
- LED wattage
- LED Colour Rendering Index Rating(s)
- shield specifications (if applicable)
- fixture light shield locations
- A chart that confirms calculated average, minimum and maximum LUX, veiling luminescence and uniformity

3.3.10 Composite Utility Plan

The Composite Utility Plan shall include sanitary sewers, storm sewers, watermain, storm water management facilities, and all easements. Lot numbering and lot fabric shall match that of the registered plan. The Composite Utility Plan shall show all proposed and existing services required for servicing the proposed development and serves as a "key" plan for the remainder of the drawing set. In addition, the Composite Utility Plan shall satisfy the following requirements:

- scale shall be 1:500;
- metric A1 sheet;
- north arrow;
- location of all existing and proposed utilities;
- offsets from property line;
- location of all proposed street trees;
- location of all proposed streetlights;
- location of all driveways; and,
- all drawings to be stamped, signed and dated by a professional engineer.

3.3.11 Landscape Plan

The landscaping plan shall include all plantings, tree, and landscaping features proposed as part of the development. In addition, the Landscaping Plan shall satisfy the following requirements:

- scale shall be 1:500;
- metric A1 sheet;
- north arrow;
- location of all trees, shrubs, and miscellaneous plantings;
- complete list of tree/planting sizes, common name, species name, and quantities;
- All drawings are to be stamped, signed and dated by a landscape architect

3.4 "As-Constructed" Drawings

The "As-Constructed" Drawings constitute the original engineering drawings, which have been amended to incorporate the construction changes and variances to provide accurate information on the works as installed in the development. The Registered Plan Number must be clearly shown on all "As-Constructed" Drawings.

3.4.1 “As-Constructed” Field Survey

The "As-Constructed" revisions shall be based on a final survey of all the subdivision services and from construction records. The final survey of the subdivision services shall include a field check of the following items:

- location and invert elevations of all sewer manholes and revised grade of sewers
- distance between manholes
- location of all roadway catchbasins
- location, lid and invert elevations for all rear yard catchbasins
- location of curb and sidewalk
- location of hydrants
- location and ties to all valve boxes and valve chambers located in landscaped areas
- location and ties to watermain (horz. & vert.) all blow-offs and other special watermain appurtenances
- road centreline elevations
- location and elevation site benchmarks established during construction
- location of all service connections to all lots and blocks and chainage of the connection at the sewer to the nearest downstream manhole
- all sewer and watermain sizes, material, bedding type
- location of fencing constructed as part of the subdivision services
- location of all street light poles and transformers

3.4.2 Drawings Revisions

The original drawings shall be revised to reflect the "As-Recorded" changes which were documented by the consulting engineer. The drawing revisions shall include but are not limited to the following:

- all sewer and road grades are to be recalculated to two decimal places
- all screening shall be removed
- all street names, lot and block numbering and dimensions shall be checked against the registered plan
- an "As-Recorded" revision note shall be placed on all drawings

3.4.3 Submission of “As-Constructed” Drawings

Upon completion of all underground and road construction the "As-Constructed" drawings shall be submitted to the Town of Tillsonburg Operations and Development Services on 'white prints' for review. When the drawings have been revised to the satisfaction of the Town, the engineering consultant will supply the Town with one set of stamped "As-Constructed" mylars and

an AutoCAD digital file for their records.

The information shown on the "As-Constructed" drawings may be checked by the Town at any time up to two years from the "Final Acceptance" of the development and if discrepancies are found between the information shown on the drawings and the field conditions, the drawings will be returned to the Engineering Consultant for rechecking and further revisions.

The Engineering Consultant may be required to explain, in writing, any differences between the design and the "As-Constructed" data and provide verification that the alterations will not adversely affect the design of the subdivision services. The "As-Constructed" drawings shall be submitted to the Town before "Preliminary Acceptance" for the underground works will be given.

3.4.4 GIS Information

Finalized digital CAD files, properly georeferenced (NAD 83 17N) are to be provided, showing all services for the entire development with each asset category drawn on its own layer.

3.4.5 Asset Management Information

As part of the submission of "As-Recorded" drawings, it is necessary to supply all infrastructure attribute information for the development to the Town in a spreadsheet format that will allow for importation into the Towns Asset Management system (sample spreadsheets and datasets are included in Appendix 3-1 for this purpose). The collection of infrastructure attribute information is required to enable efficient lifecycle management practices for infrastructure and to account for infrastructure assets on annual financial statements.



Section 3 - Appendix “3-1”
Asset Management Plan Data Table Example

ROAD		
FIELD NAME	DATA TYPE	COMMENTS
RoadID	Text	To be assigned by ToFT
STREET NAME	Text	
XSTREET1	Text	
XSTREET2	Text	
CLASS	Number	
TYPE	Text	Alley, Arterial, Collector, Local
MATERIAL	Text	
LENGTH (m)	Number	
# OF LANES	Number	
GRAN_A (mm)	Number	
GRAN_B (mm)	Number	
BASE (mm)	Number	
SURFACE (mm)	Number	
COMPLETION DATE	Date	
DATA SOURCE	Text	e.g. Drawing #

CURB		
FIELD NAME	DATA TYPE	COMMENTS
RoadID	Text	To be assigned by ToFT
STREET NAME	Text	
XSTREET1	Text	
XSTREET2	Text	
LENGTH (m)	Number	
OPSD #	Number	
COMPLETION DATE	Date	
DATA SOURCE	Text	e.g. Drawing #

SIDEWALK		
FIELD NAME	DATA TYPE	COMMENTS
RoadID	Text	To be assigned by ToFT
STREET NAME	Text	
XSTREET1	Text	
XSTREET2	Text	
LENGTH (m)	Number	
WIDTH (m)	Number	
MATERIAL	Text	
COMPLETION DATE	Date	
DATA SOURCE	Text	e.g. Drawing #

POLE		
FIELD NAME	DATA TYPE	COMMENTS
POLE ID	Text	
LOT #	Number	
STREET #	Number	Service address #
STREET NAME	Text	Service address street name



Section 4

Table of Contents

4	SITE PLAN APPROVAL PROCESS	1
4.1	General Requirements.....	1
4.2	Introduction.....	1
4.2.1	Definition of Development	1
4.2.2	Site Plan Approval Required	2
4.2.3	Goals of Site Plan Control	3
4.3	Site Plan Control Process	3
4.3.1	Approval Process	3
4.3.2	Site Plan Approval Pre-consultation.....	4
4.3.3	Exempt from Site Plan Approval	4
4.3.4	Minor Site Plan Approval Application	6
4.3.5	Major Site Plan Approval Application	7
4.3.6	Site Plan Amendment Application.....	7
4.3.7	Site Plan Approval Application Submission.....	8
4.3.8	County, Town and Agency Review.....	8
4.3.9	Site Plan Meeting, Review and Resubmission of Plans	9
4.3.10	Public and Town Council Information/Consultation	9
4.3.11	Final Approval	10
4.3.12	Agreement or Undertaking Execution	11
4.3.13	Building Permit.....	11
4.3.14	Post-Construction.....	11
4.3.15	Partial Release of Performance Securities.....	12
4.3.16	Release of Performance Securities for Landscaping.....	13
4.3.17	Drawing Upon the performance security – Failure to Complete Works.....	13
4.3.18	Appeals.....	14
4.3.19	Red-line Amendments.....	14
4.3.20	Minor Corrective Amendments	15



Appendices

Section 4 - Appendix "4-1" Site Plan Approval Pre-Consultation Application

Section 4 - Appendix "4-2" Site Plan Approval Application

Section 4 - Appendix "4-3" Cost Estimate of Site Works and Services

4 SITE PLAN APPROVAL PROCESS

4.1 General Requirements

In the Province of Ontario, Section 41 of the Planning Act authorizes municipalities to employ Site Plan Control as a land use tool to ensure the appropriate location of a development on a site and to ensure the safety, attractiveness and compatibility with the surrounding land. This section is to inform potential developers and the public about the process of Site Plan Control within the Town of Tillsonburg.

4.2 Introduction

4.2.1 Definition of Development

For the purposes of Site Plan Control, development is defined in the Planning Act as:

... the construction, erection or placing of one or more buildings or structures on land or the making of an addition or alteration to a building or structure that has the effect of substantially increasing the size or usability thereof, or the laying out and establishment of a commercial parking lot or of sites for the location of three or more trailers as defined in subsection 164 (4) of the Municipal Act, 2001 or subsection 3 (1) of the City of Toronto Act, 2006, as the case may be, or of sites for the location of three or more mobile homes as defined in subsection 46 (1) of this Act or of sites for the construction, erection or location of three or more land lease community homes as defined in subsection 46 (1) of this Act. R.S.O. 1990, c. P.13, s. 41 (1); 1994, c. 4, s. 14; 2002, c. 17, Sched. B, s. 14 (1); 2006, c. 32, Sched. C, s. 47 (8). (S. 41(1) Planning Act, R.S.O. 1990, c. P.13)

In addition to the provisions in the Planning Act, within Oxford County and its local area municipalities, the general policies for use of Site Plan Control are contained in the County of Oxford Official Plan. **The Official Plan defines the entire Town as a proposed Site Plan Control area.** Development in the Town is further regulated through the Town of Tillsonburg Zoning Bylaw No. 3295 as amended, the Town Site Plan Control By-law and other applicable By-laws.

Pursuant to Section 41 of the Planning Act, the Council of the Town of Tillsonburg has enacted a comprehensive Site Plan Control By-law. The Town's Site Plan Control Bylaw 4151 as amended identifies the development situations and land use classes subject to Site Plan Control and exempts certain classes of land use from these controls. This by-law also outlines the requirements for the submission of plans and drawings, and where necessary appropriate studies, prior to permitting "development" on the lands which are subject to Site Plan Control.

4.2.2 Site Plan Approval Required

Site Plan Approval (SPA) is required for all commercial, industrial, institutional, private recreational and medium or high-density residential types of development in the following situations:

The construction, erection or placing of one or more buildings or structures on the land

An interior or exterior alteration to a building or structure on a property that has the effect of increasing the usability of the property

An addition or alteration to a building or structure on a property that has the effect of increasing the size of the building or structure in an industrial zone by more than 30% of the gross floor area or increasing the size of the building or structure in all other zones by more than 20% of the gross floor area, subject to the review of the proposal by the Town and County

- The making or construction of, or addition to, a commercial, institutional or industrial parking lot resulting in five or more parking spaces
- An amendment to an existing site plan, elevation plan, landscape plan, and/or servicing plan or an amendment to an existing site plan agreement with the Town

It should be noted that all submissions must meet the requirements of the Town Zoning By-law No. 3295 as amended and the County of Oxford Official Plan, otherwise planning approval will be required prior to the final approval of a site plan application.

The following classes of development are exempted from site plan approval:

- Dwellings: single detached dwelling, semi-detached dwelling, duplex dwelling, triplex dwelling, freehold street-fronting townhouses on public streets and converted dwelling containing a maximum of two (2) dwelling units, as well as all residential accessory buildings
- An addition or alteration to a building or structure mentioned in Section 2.1 of Site Plan Control By-law (as amended)
- Placement of a portable classroom on a school site of a district school board if the school site was in existence on January 1, 2007
- Agricultural and farm-related buildings, building additions, building alterations or structures that are utilized in farming operations, but not including agricultural, commercial or industrial operations such as farm equipment sales and service, farm supply sales and agricultural storage, service or supply establishments
- For more information please see the section titled Exempt from SPA found in section 44.3.3.

4.2.3 Goals of Site Plan Control

The principal goals of Site Plan Control are to:

- Ensure the safety and convenience of vehicular and pedestrian traffic to, from, and on the site of a new development or redevelopment
- Reduce the cost to the Town where development requires the widening of existing roads or the granting of easements for Town purposes
- Ensure that off-street parking and loading facilities are properly located, constructed and maintained during all seasons
- Improve the quality and aesthetic appearance of developments for greater enjoyment by the users and tenants
- Improve the image of the Town through well designed individual developments
- Ensure proper stormwater management, drainage, lot grading for individual developments
- Proper and adequate Town services and utilities are provided

4.3 Site Plan Control Process

4.3.1 Approval Process

In order to expedite SPA applications, the Town has created three separate application types, Minor, Major and Amendment.

Minor SPA applications will take approximately 15 business days from submission of a complete application if the application conforms to the provisions in the Town of Tillsonburg Zoning By-law No. 3295 as amended, the policies of the County of Oxford Official Plan, the Town's SPA Guidelines, and other applicable policies and guidelines. Major applications will take approximately 25 business days from submission of a complete application. Site Plan Amendment applications will vary in the length of time to approve based on the complexity of the proposed development.

Please note that the application process can be expedited by ensuring that all submitting drawings and reports meet the requirements of the SPA Guidelines. In order to ensure a complete application, it is recommended to contact Staff to arrange for a pre-consultation meeting (application attached as Appendix "4-1"). After the pre-consultation meeting, the Proponent completes the SPA application form (attached as Appendix "4-2"), and completes the attached SPA application checklist, supplies cost estimates (attached as Appendix "4-3", if necessary) along with all required drawings/reports/studies/etc.

Furthermore, timely resubmission of amended plans based on comments/concerns of commenting agencies can also greatly expedite the approval process.

4.3.2 Site Plan Approval Pre-consultation

The Town encourages that the Proponent and their agents (if applicable) meet with the County Development Planner and Town staff (if applicable) to discuss the development proposal before submitting any application for SPA. The purpose of the meeting is to advise the Proponent of the various Official Plan policies and Zoning By-law provisions which apply to the development. The review of these policies and provisions will assist the Proponent in the design of the site such as the placement of the proposed buildings, structures and other built features before preparing the required site plan drawings.

If it is identified that additional planning approvals are required before the proposed site plan could be considered for approval, staff will discuss with the Proponent in determining if an application for planning approval should be submitted and considered concurrently with the site plan application.

In order to determine if SPA is applicable, and to assist the Proponent in the preparation of a complete application package, the County Development Planner and Town staff will complete a checklist of what is required to constitute a complete application based on the proposed development on the subject lands. This SPA pre-consultation application can be found attached as Appendix "4-1".

After the completion and submission of the SPA pre-consultation application staff will review the proposal and determine if the proposed development is:

- Exempt from SPA
- An Amendment to an existing SPA
- A minor SPA application
- A major SPA application

It is anticipated that any required drawings, reports, and or studies will be identified during the above noted review. The Proponent will be expected to provide such studies in conjunction with the completed SPA application.

Please be advised that the SPA pre-consultation application is provided to assist the Proponent in moving forward with the proposed development. The above should not be considered an exhaustive list, as additional requirements or information may be identified through a complete review of the formal submission of all required drawings, studies, and reports.

4.3.3 Exempt from Site Plan Approval

Upon the completion and submission of the SPA pre-consultation application, planning staff will discuss the proposal with applicable Town staff and if necessary, additional applicable agencies. Staff will review the proposal against the policies of the Official Plan, Zoning By-law and Site Plan Control Guidelines and Site Plan Control By-law.

The following shall be considered by staff when determining if the proposal should be exempt from Site Plan Control Approval:

- Is the proposal for greenfield development? (Note that new development proposals will not be exempted from Site Plan Control Approval and will generally require either Minor or Major SPA)
- Does the proposed development have the effect of increasing the size of the building or structure in an industrial zone by more than 30% of the gross floor area or increasing the size of the building or structure in all other zones by more than 20% of the gross floor area?;
- Interior renovations will generally be exempt from Site Plan Control Approval, unless a change of use permit is required and the required amount of parking increases.
- Are there any environmental features or constraints as identified by the Official Plan located on the subject property or within the immediate area?
- Does the extent or scale of the development proposal suggest that a Professional Engineer or other professional(s) be retained to review the development proposal?
- Do existing site conditions complicate the development (i.e. topography, slopes, previous hazardous uses)?
- Does the proposed development conform to the Zoning By-law, Official Plan or any agreements, or are there property standards complaints, open storage problems, outstanding stop work orders, or other matters of Town interest?
- Are there any obvious parking, loading or access problems?
- Are there any obvious drainage or storm water management problems/concerns?
- Are there requirements for internal/external servicing improvements, construction or road works?
- Is the proposed development compatible with the surrounding area in terms of conceptual massing/design?
- Would any traffic hazards and other safety issues result from the development?
- Would the proposed development result in land use conflict/compatibility concerns?
- Is the property subject to an existing Site Plan and/or Agreement?
- Has Council requested a full review of the site?
- Is stormwater management required?
- Are municipal drains located on subject property?
- Geotechnical analysis required?

Within 5 to 7 business days of submission of the SPA pre-consultation application, staff will determine if the proposed development is exempt from SPA. If exempt, a building permit application may be submitted for approval.

If the Town has determined that the proposed development is not exempt from SPA, then the Proponent must submit either a Minor, Major or Site Plan Amendment Approval Application.

4.3.4 Minor Site Plan Approval Application

Minor SPA applications can be required for minor development proposals such as a change of use of an existing building, building additions, or by means of the provisions of the Zoning By-law. The Proponent of the subject lands shall submit a detailed drawing of the subject lands which illustrates the proposed development including all other necessary drawings/reports/studies as identified through the pre-consultation application. If during the site plan review stage, it is determined that the proposed development requires changes to an approved grading plan or may have off-site impacts, the application will be considered a major application and additional fees shall be required.

The Proponent will retain the services of qualified professionals to prepare computer generated site plan required by staff, as noted by the Pre-consultation application. The plans shall be prepared to scale and in metric format, and shall include the following information:

- Registered property Proponent, signature and date
- Legal description and roll number
- Brief statement explaining the proposed development
- Scale, north arrow, and clearly legible labeling
- Property limits and dimensions which coincide with a survey or assessment records
- Location and footprint of all existing and proposed buildings and structures on the subject property
- Identification of all surrounding uses, including distances and locations of all adjacent structures on all adjacent properties
- Access locations
- Delineation of asphalt, grassed, and graveled areas
- Existing on-site drainage, including drainage swales or catch basins
- Location of all signs and lighting
- Location of any nearby hydrants, utility poles or other services for the property or surrounding area
- Landscaping (trees, shrub beds, berms, swales)
- Stormwater management report prepared by a Professional Engineer
- Site statistics including:
 - Property area
 - Percentage of the property which is developed
 - Area of site covered by buildings

- Gross floor area of all buildings
- Number of parking spaces and loading spaces
- Percentage of the site which is landscaped

Upon submission of the complete Minor SPA application and all required drawings/reports/studies, the application will be circulated to various Town staff and other applicable agencies for comment. Comments will be forwarded to the Proponent within 10 business days. The Proponent will be required to address all concerns prior to approval being granted.

Under the Minor SPA process, a Site Plan Agreement or Undertaking is required. The Agreement or Undertaking will be drafted by Town staff, and forwarded to the Proponent of the lands for signatures. The Agreement will then be sent to the Town and signed by the Director of Operations and Development and Chief Administrative Officer. The Agreement must be registered on title of the subject lands, which the Town's solicitor will execute at cost to the Owner.

4.3.5 Major Site Plan Approval Application

In circumstances where approval of a Major SPA Application is required, the Proponent will retain the services of qualified professionals to prepare any necessary drawings or supporting documents, as noted by Town staff during the pre-consultation application.

The process for full Site Plan Control Approval shall generally be as follows (additional details can be found in the checklist as part of the Site Plan Approval Application form):

- Submission of a complete set of plans and the requisite application and fee
- Review of plans by the Town, agencies and appropriate professionals (25 business days)
- Revisions of the plans to address concerns
- Town and County staff approval of the plans and preparation of the Site Plan Agreement
- Posting of performance securities based upon the Cost Estimate of all outside works
- Execution of the Site Plan Agreement by the Town and the Proponent
- Site Plan Agreement is registered on title of the subject lands and proof of registration is provided
- Clearance to the Building Department and commencement of the building permit process

4.3.6 Site Plan Amendment Application

Development proposals for lands which are already subject to an existing Site Plan Agreement or approved site plan that proposes a major addition or alteration will be processed in accordance with the Town's Major Site Plan Application process unless otherwise noted by the County Development Planner, in consultation with the Manager of Engineering and Chief Building Official. Subsequent to SPA Pre-consultation, and within 25 business days the Town and County staff will

utilize the following criteria to determine whether a development proposal is considered major and therefore requires an amendment to the existing Site Plan Agreement:

- An addition or alteration to a building or structure on a property that has the effect of increasing the size of the building or structure in an industrial zone by more than 30% of the gross floor area or increasing the size of the building or structure in all other zones by more than 20% of the gross floor area, subject to the review of the proposal by the Town and County staff

4.3.7 Site Plan Approval Application Submission

The SPA process is initiated by submitting a completed Amendment, Minor or Major SPA application, all required drawings, approvals, reports and studies, and the required fee to the Town of Tillsonburg Customer Service Centre or the County of Oxford Community Planning Office. The SPA application form can be found in Appendix “4-2” of this document. Additional application forms are available at the local Town office, the Oxford County Community Planning Office, and online on the Town and County websites. The required application fee must accompany the completed application. The applicable application fee is contained within the Town’s Rates and Fees By-Law, as amended. **Please note that the fee is payable to the Town of Tillsonburg. Please refer to section 5 for SPA submission requirements.** For information regarding the application fee please contact the Town of Tillsonburg , or visit the County’s Community Planning Office website or the Town of Tillsonburg website (<https://www.tillsonburg.ca>). A checklist of complete application submission requirements are contained within the SPA application form (Appendix “4-2”).

Please note that applications will not be circulated unless deemed to be complete by the County Development Planner.

4.3.8 County, Town and Agency Review

The County Development Planner will review the initial submission and forward to Town staff. The Town’s Development Engineering Technologist will circulate the following public agencies, as required:

- Town staff including, Chief Building Official, Fire Chief, Director of Operations, Manager of Engineering, Director of Recreation, Culture and Parks, Town Water/Wastewater supervisor, Town Development Commissioner, Manager of Public Works & Hydro Design.
- County of Oxford Community Planning Office
- County of Oxford Public Works Department
- Applicable local utility companies (THI)
- County of Oxford Public Health and Emergency Services Department
- County or Town Accessibility Advisory Committee
- Applicable companies.

Depending on the location and nature of the development, the developer may be required to obtain approvals from various other regulatory agencies including (but not limited to) one or more of the following and in addition to and/or prior to obtaining approval from the Town:

- The Department of Fisheries and Oceans (DFO)
- The Ministry of Environment, Conservation and Parks (MECP)
- The Ministry of Natural Resources (MNR)
- The Ministry of Transportation (MTO)
- The Ministry of Tourism, Culture and Sport (MTC)
- Long Point Region Conservation Authority (LPRCA)

It is the responsibility of the developer to provide the Town with suitable written documentation of the approval from the regulatory agencies.

The development will be subject to the requirements of all by-laws within the Town.

Other agencies may be circulated depending on the location and scope of the application. The Proponent will be notified, in writing, if the circulated agencies require revisions of the site plan drawings or if additional information is required.

4.3.9 Site Plan Meeting, Review and Resubmission of Plans

The Proponent will receive an acknowledgement letter, recognizing receipt of the application. If necessary, a site plan meeting will be scheduled with the Proponent, Town and County staff, and if necessary, circulated agencies to review the application and agency comments. This meeting shall be held once the comments from all applicable departments/agencies have been received.

Once all requested comments have been received, the County Development Planner will consolidate all comments and concerns into a formal response and forward them to the Proponent requesting the required revisions to site specific design information, additional information or studies. If requested, the Town and County staff will meet with the Proponent to discuss concerns regarding the proposed development and to clarify resubmission requirements.

Any subsequent site plan resubmission shall include a letter from the Proponent stating in bullet form how they have addressed each of the concerns/comments in the formal response from the Development Engineering Technologist

4.3.10 Public and Town Council Information/Consultation

At the discretion of Town Staff, the Proponent may be required to hold a public information/consultation session to advise the public of the proposed development.

The public information/consultation session is to be conducted at the expense of the Proponent, at a time and location to the satisfaction of the Town. A public notice sign will be erected on the

subject lands advising of the public meeting. Written notification will also be circulated to neighbouring property Proponents within 120m.

Town Council may require the proposed development to be brought forward to a Town Council meeting for information.

4.3.11 Final Approval

For the purposes of SPA, in accordance with Subsection 41(13)(b) of the Planning Act and the Town's Delegation By-law 2020-091 , the authority to approve plans and drawings required for any Site Plan application in the Town has been delegated to the County Development Planner and the Town.

Upon receipt of the final plans and documents, Town staff will prepare the Site Plan Agreement or Undertaking. The approved plans and documents will be noted in the Site Plan Agreement.

4.3.12 Agreement or Undertaking Execution

Once the Site Plan Agreement or Undertaking has been prepared, the following steps will be taken:

- The Proponent will be sent the agreement to be signed by the owner and returned to the Town for signing.
- The Proponent will provide both digital and hard copies of the approved drawings
- The Proponent will provide securities to the Town
- The Agreement must be registered on title prior to the issuance of a building permit, the Town will have this done by their solicitor at cost to the Owner.
- The Owner shall obtain additional approvals from other government agencies or ministries as may be required prior to the issuance of a Building Permit
- Once the Site Plan Agreement has been signed by all parties, the Town has received all performance securities, and the Town has received documentation that the Site Plan Agreement has been registered on title of the subject lands, Town staff shall advise the Chief Building Official that a building permit can be issued

4.3.13 Building Permit

Construction of buildings or structures cannot commence until the Undertaking has been signed or the Site Plan Agreement has been signed by all parties, registered on title, all performance securities have been received by the Town, and all permits required for the development have been obtained from the regulatory agencies. Town staff will notify the Chief Building Official when the Undertaking has been signed or the executed Agreement has been registered on title, and the required performance securities and approvals have been received. The building permit may then be issued to the Proponent.

4.3.14 Post-Construction

All of the works required by the agreement or undertaking shall be completed within two years of the date of building permit issuance, or one year of the date of approval of the site plan if no building permit is required, unless otherwise approved by Town and County staff and specified in the Site Plan Agreement. In anticipation of construction taking longer than two years to complete, the Proponent shall provide written correspondence to the attention of the County Development Planner advising:

- When the approved development will be completed
- What is remaining to be constructed/installed
- Why the approved development has not been constructed within the two-year period

Upon completion of all site works, the Proponent may request the return of all performance securities. The Proponent must provide the Town written confirmation from the consulting engineer that all site works have been completed as per the Agreement and all approved stamped

drawings. The Proponent may be required to provide any professional reports or 'As-Recorded' drawings to confirm the completion of works such as final grading and stormwater management facilities on the subject property, prior to the return of any applicable performance security.

The Manager of Engineering or Development Engineering Technologist and the Chief Building Official will undertake a final site inspection of the development to ensure construction conforms to the approved stamped drawings, after which they will advise the Director of Finance in writing that all site works have been completed and that the performance security can be released.

4.3.15 Partial Release of Performance Securities

Performance securities held by the Town may be released in stages as development progresses to the satisfaction of the Manager of Engineering or Development Engineering Technologist, and Chief Building Official. Prior to the release of partial performance securities, the Proponent must provide the Town written confirmation from the consulting engineer that certain site works have been completed as per the Agreement and all approved stamped drawings. These performance security reductions are dealt with on a request basis. The Proponent will be required to complete the necessary release of performance securities form. The Proponent will be notified within 15 business days of submission of the above if the Town is satisfied to release a portion of the held performance securities.

The Proponent shall be required (at their expense) to provide any professional reports (usually in the form of an Engineer's certificate) along with 'As-Recorded' drawings to confirm the completion of works such as final grading and stormwater management facilities on the subject property, prior to the return of any requested partial performance security. The Proponent will provide a detailed cost estimate stamped by a Professional Engineer.

The Engineer's certificate will provide the following:

- All Services and Works have been constructed in conformance with the approved drawings
- Rough grading has been completed to provide a proper outlet for the major design storm
- All hydrant testing has been completed in the presence of a licensed Operator from the County and/or designated service provider
- All sanitary and storm manholes and catch basins have been flushed and cleaned along with a CCTV inspection of the sanitary and storm systems
- Retaining wall structures are structurally sound and were constructed as per the approved design drawings and applicable standards

If the work required by the agreement is not completed as required in the Agreement, the performance securities or portion thereof will be retained until the deficiencies are remedied. Upon failure of the Proponent(s) to remedy the situation to the satisfaction of the Town, the Town may choose to cash and/or draw upon the performance security.

If any elements of the works have been constructed contrary to the Agreement, revised plans shall be submitted by the consulting Engineer detailing the changes which have been made and the reasons behind the changes. The Town will review the changes to determine if they are acceptable and whether or not an amendment to the site plan is required. If the changes are acceptable and no Amendment is required, the Town will then inspect the site to determine whether or not a reduction in the performance security is justified. If the changes are not acceptable, or if an amendment is required to reflect the changes, no reduction in the performance security respecting the changes can occur until all relevant departments/agencies have approved the changes, or portion thereof, to have the deficiencies corrected.

The Manager of Engineering or Development Engineering Technologist and the Chief Building Official will undertake a site inspection of the development to ensure construction conforms to the approved stamped drawings, after which they will advise the Director of Finance in writing that the noted site works have been completed and that an applicable portion of the performance security can be released. *In all instances, the Town will retain a portion of the performance security (10%) until one year after all works have been completed. This is to ensure performance security against deficiencies, which may occur within that year.*

4.3.16 Release of Performance Securities for Landscaping

Performance securities held by the Town for landscaping purposes will be held until June following the end of the first growing season to ensure all installed landscaping has survived the winter and is healthy.

4.3.17 Drawing Upon the performance security – Failure to Complete Works

In the event of any failure by the Proponent to carry out any provisions of the Agreement, the determination of which shall be at the sole discretion of the Chief Administrative Officer and/or the Director of Operations, the Town may provide Notice to the Proponent of the nature of the failure. Such notice may provide that the Director of Finance will cash any performance security held by the Town.

If, as a result of any work undertaken or not completed by the Owner, there exists in the opinion of the Town's Chief Building Official in his or her sole discretion an emergency which requires immediate attention, the Town, its authorized employees, contractors, and agents may enter upon the Property and complete or repair such work at the sole expense of the Owner. In the event of such emergency, the Town shall provide written or verbal notice to the Owner at the earliest practicable opportunity.

In the event costs are incurred by the Town in performing the works or services required to be affected or deemed by the Town to be necessary pursuant to this Agreement, the Proponent will forthwith pay such costs to the Town, upon demand therefore. In the event of failure by the Proponent to pay such costs within thirty (30) business days of receiving Notice thereof from the Town, the Town shall have the right to recover such costs by drawing upon the performance security.

In the event the costs incurred exceed the amount of the performance security, the Town shall have the right to recover such incurred costs by legal action or in like manner and with the same priority as municipal taxes. The performance security may also be used to remedy deficiencies and/or damages within the road allowance relating to the completion of development of the subject lands.

Up to ninety percent (90%) of any performance security provided to the Town by the Proponent may be returned by the Town to the Proponent without interest when the Works required by the terms and provisions of this Agreement have been completed by, and at the expense of, the Proponent to the satisfaction of the Town. Any reduction in performance security will not occur prior to a written request by the Proponent and a recommendation by the Chief Building Official and Manager of Engineering to the Director of Finance that such reduction be permitted.

A maximum of ten percent (10%) of the initial performance security provided to the Town by the Proponent shall be retained by the Town for a minimum period of one year (commencing on the day that ninety percent (90%) of a deposit has been returned to the Proponent) as a guarantee against any defects that may occur with regard to any building, structure or work effected by the Proponent or on the lands pursuant to the terms of this Agreement and these funds may be used by the Town to pay the expense of rectifying or remedying any such defect. If, after the expiry of this one-year guarantee period, no outstanding defects are found that relate to the lands or to any of the buildings, structures or works in or on the lands, the performance security remaining in the hands of the Town, shall be returned to the Proponent.

4.3.18 Appeals

Under Section 41(12) of the Planning Act, if the Town does not approve a complete application within thirty (30) business days after it has been received or the Proponent is not satisfied with the any of the requirements made by the Town, including any terms of the required Site Plan Agreement, the Proponent may appeal to the Local Planning Appeal Tribunal (LPAT).

Written notice of appeal, including the reasons for appeal and prescribed fees, must be lodged with both the LPAT and the Clerk. After receipt of an appeal, the LPAT will schedule a hearing and determine the matters of issue. Once the LPAT has issued a decision/order, the Proponent shall enter into a Site Plan Agreement with the Town to implement the LPAT decision. The decision of the LPAT is final and binding on all parties.

4.3.19 Red-line Amendments

All approved SPA drawings may be subject to minor red line amendments in accordance with the Town of Tillsonburg SPA Guidelines, to the satisfaction of the Town of Tillsonburg, and authorized by the delegated approval authorities. The Clerk of the Town of Tillsonburg and the County of Oxford shall keep a copy of any redline amendment on file with the original agreement.

4.3.20 Minor Corrective Amendments

Minor grammatical, cross referencing or formatting amendments to the Site Plan Guidelines or the Site Plan Control By-law may be undertaken at the discretion of the delegated approval authorities, without amendment to the Site Plan Control By-law.



Section 4 - Appendix “-1”
Site Plan Approval Formal Pre-Consultation Application

Appendix 'A'

Site Plan Approval Formal Consultation

Office Use Only

Date Received	Date Circulated	File No.
---------------	-----------------	----------

PART I CONTACT INFORMATION

NAME	ADDRESS	TELEPHONE NO.
Registered Owner)		Home:
		Business:
		Email:
Applicant (if different from Owner)		Home:
		Business:
		Email:
All correspondence should be sent to (check one)		<input type="checkbox"/> Owner <input type="checkbox"/> Applicant

PART II GENERAL PROPERTY DESCRIPTION

1. Address & Legal Description

Municipal Address	Lot	Concession	Former Township
Registered Plan No.	Lot/Block	Reference Plan No.	Part

2. Particulars of Subject Lands

Frontage	Depth	Area
----------	-------	------

3. What is the current use of the subject lands?



Development & Communications Services
200 Broadway, 2nd Floor

Tillsonburg, Ontario N4G 5A5I: (519) 842-9200
Fax: (519) 688-0759

Site Plan Approval

FEE SAMPLE ONLY
NOT AS SHOWN

Site Plan Approval—Formal Consultation

CONTINUED

PART III	PROPOSAL
-----------------	-----------------

1. Provide a brief description of the proposal.

2. Sketch Provided? Yes No

PART IV	ZONING & OFFICIAL PLAN INFORMATION
----------------	---

Current Zoning Category: _____

Current Official Plan Designation: _____

PART V	OTHER USEFUL INFORMATION
---------------	---------------------------------

1. Provide any other useful information for consideration

Site Plan Approval—Formal Consultation

CONTINUED

Office Use Only

PART VI	TYPE OF SITE PLAN APPLICATION REQUIRED
----------------	---

Proposed development is considered:

<input type="checkbox"/> Exempt from Site Plan Approval	<input type="checkbox"/> Minor Site Plan Application (\$1950.00)
<input type="checkbox"/> Amendment to Existing Site Plan Approval (\$1700.00)	<input type="checkbox"/> Major Site Plan Application (\$2700.00)

PART VII	REQUIRED SUPPORTING DRAWINGS/REPORTS/STUDIES/ETC
-----------------	---

Department of Development and Communication Services

<input type="checkbox"/> General Plan (3 copies) To be stamped and endorsed by a professional: <input type="checkbox"/> Minor Application: P. Eng or <input type="checkbox"/> OLSMajor Application: P. Eng.	Showing dimension of subject lands, all buildings & structures, all setback information, parking space and aisle dimensions, general vegetation, etc. Please see the Site Plan Approval Guidelines for more information as what is required to be included on submitted drawings.
<input type="checkbox"/> Building Elevations (3 copies) To be stamped and endorsed by a professional: <input type="checkbox"/> P. Eng <input type="checkbox"/> Architect <input type="checkbox"/> Qualified Designer	Shows the proposed façade and window treatments of all sides of a proposed development, certain situations may require the provision of drawings in colour.
<input type="checkbox"/> Site Plan Agreement or Undertaking <input type="checkbox"/> Site Plan Agreement <input type="checkbox"/> Undertaking	The Agreement or Undertaking is drafted by the Town, signed by the Town and the owner of the lands. The Agreement is to be registered on the title of the lands, or the Undertaking signed and returned to the Town prior to the issuance of a building permit.
<input type="checkbox"/> Market Impact Study (3 Copies) To be prepared by a qualified economist	This report will be required to be peer reviewed. Applicant may be required to provide a \$1,500.00 deposit for this peer review.
<input type="checkbox"/> Landscaping Plan (3 copies) To be stamped and endorsed by a professional: <input type="checkbox"/> Minor Application: OALA, P. Eng or Qualified Professional Major Application: OALA or P. Eng. <input type="checkbox"/>	Shall be required for all medium and high density residential, commercial, institutional and industrial development unless otherwise noted.
<input type="checkbox"/> Fire Safety Plan (6 Copies) To be prepared to the satisfaction of the Town Fire Chief	Please contact the Town Fire Chief for information as to the requirements of a Fire Safety Plan.
<input type="checkbox"/> Archeological Study (6 Copies) To be stamped and endorsed by a professional Archeologist	This study must be sent to the Ministry of Culture for review and comment.
<input type="checkbox"/> As-Built Drawings (6 Copies) To be stamped and endorsed by a professional P. Eng	Required to show all completed works. If As-Built drawing differs from the approved plans a Site Plan Amendment application may be required.

Site Plan Approval—Formal Consultation

CONTINUED

Office Use Only

PART VII	REQUIRED SUPPORTING DRAWINGS/REPORTS/STUDIES/ETC (continued)
-----------------	---

Engineering Department

<input type="checkbox"/> Grading and Drainage Plan (3 Copies) To be stamped and endorsed by a professional P. Eng	Including all existing and proposed grades as well as direction arrows and percentages. See the Site Plan Approval Guidelines for more detailed information.
<input type="checkbox"/> Servicing Plan (3 Copies) To be stamped and endorsed by a professional P. Eng	Showing all existing and proposed private or municipal services, including sanitary sewer, storm sewer, water, hydro, gas, telephone, etc. See the Site Plan Approval Guidelines for more detailed information.
<input type="checkbox"/> Illumination Study (3 Copies) To be stamped and endorsed by a professional electrical Engineer or Architect.	
<input type="checkbox"/> Stormwater Management Plan (3 Copies) To be stamped and endorsed by a professional P. Eng	Includes a detailed description as to how stormwater is proposed to be directed and collected.
<input type="checkbox"/> Traffic Impact Study (3 Copies) To be stamped and endorsed by a professional P. Eng	This report will be required to be peer reviewed. Applicant may be required to provide a \$1,500.00 deposit for the peer review.
<input type="checkbox"/> Slope Stability Study (3 Copies) To be stamped and endorsed by a professional Geotechnical Engineer	May be required to be reviewed by the LPRCA.
<input type="checkbox"/> Geotechnical Report (3 Copies) To be stamped and endorsed by a professional P. Eng	May be required to be reviewed by the LPRCA.
<input type="checkbox"/> Noise & Vibration Feasibility Study (3 copies) To be stamped and endorsed by a professional P. Eng	This report will be required to be peer reviewed. Applicant may be required to provide a \$1,500.00 deposit for this peer review.
<input type="checkbox"/> Environmental Impact Study (3 Copies) To be stamped and endorsed by a professional P. Eng	The requirement for an Environmental Impact Study shall be determined by staff from the LPRCA. Please contact Bonne Bravener at 842-4242 ext. 233 for more information.
<input type="checkbox"/> Environmental Site Assessment (3 Copies) To be stamped and endorsed by a professional P. Eng	May be required to be reviewed by the LPRCA.
<input type="checkbox"/> Record of Site Condition (3 Copies) To be stamped and endorsed by a professional P. Eng	May be required to be reviewed by the LPRCA.
<input type="checkbox"/> Cost Estimates (3 copies) To be stamped and endorsed by a professional P. Eng	Includes the estimation of costs for items in which a security will be held by the Town. See the Site Plan Approval Guidelines for detailed description of cost estimates.
<input type="checkbox"/> Securities To be provided in the form of Certified Cheque or Letter of Credit	See the Site Plan Approval Guidelines for detailed description of required Securities.

Please be advised that the above comments are provided to assist you moving forward with this proposed development. The above should not be considered an exhaustive list, as additional requirements or information may be identified through a complete review of the formal submission of all required drawings, studies, and reports.

Site Plan Approval—Formal Consultation

CONTINUED

Office Use Only

PART VIII	OTHER APPROVALS
------------------	------------------------

Prior to the Site Plan Application being approved by the County Development Planner and the Town Director of Development & Communication Services, the following additional approvals/clearances may be required:

<input type="checkbox"/> Zone Change	<input type="checkbox"/> Official Plan Amendment
<input type="checkbox"/> Minor Variance	<input type="checkbox"/> Severance/Easement/Boundary Adjustment
<input type="checkbox"/> Long Point Region Conservation Authority Approval	<input type="checkbox"/> Removal of Holding Provision (Zone Change)
<input type="checkbox"/> Union Gas Limited	<input type="checkbox"/> Bell Canada
<input type="checkbox"/> Canada Post Corporation	<input type="checkbox"/> Railway Approval
<input type="checkbox"/> Ministry of Transportation (MTO)	<input type="checkbox"/> Ministry of Environment (MOE)
<input type="checkbox"/> Ministry of Culture (MOC)	<input type="checkbox"/> Ministry of Municipal Affairs & Housing (MMAH)
<input type="checkbox"/> Ministry of Natural Resources (MNR)	<input type="checkbox"/> Other Provincial Ministry _____
<input type="checkbox"/> Rogers Cable	<input type="checkbox"/> Tillsonburg Hydro Inc.
<input type="checkbox"/> Parkland Dedication/Cash-in-Lieu	<input type="checkbox"/> Cash-in-Lieu of Parking
<input type="checkbox"/> Road Widening (Town/County/MTO)	<input type="checkbox"/> Encroachment Agreement
<input type="checkbox"/> Lifting of Reserve	<input type="checkbox"/> Demolition Permit
<input type="checkbox"/> Public Notification and Consultation Meeting	<input type="checkbox"/> Town Council Review
<input type="checkbox"/> Other _____	<input type="checkbox"/> Other _____
<input type="checkbox"/> Other _____	<input type="checkbox"/> Other _____

PART IX	TOWN/COUNTY STAFF & APPLICANT SIGNATURES
----------------	---

County Development Planner	Signature: _____	Date: _____
Chief Building Official	Signature: _____	Date: _____
Manager of Engineering	Signature: _____	Date: _____
Director of Development & Communication Services	Signature: _____	Date: _____
Owner/Applicant	Signature: _____	Date: _____

Please provide any comments/concerns on the next page

Site Plan Approval—Formal Consultation

CONTINUED

Office Use Only

PART X	OTHER COMMENTS/CONCERNS
--------	-------------------------

Please provide any additional comments or concerns in the space provided below:

FILES SAMPLE ONLY NOT AS SHOWN

NOTE: All of the above noted required drawings/reports/studies/etc must also be submitted in an **electronic format** (Adobe Acrobat .pdf). The electronic files shall be suitably named for convenient access and circulation, and submitted via a compact disc (CD).



Section 4 - Appendix "4-2"
Site Plan Approval Application



APPENDIX "B"
TOWN OF TILLSONBURG SITE PLAN APPLICATION FORM

FILE NO. _____

REC'D: _____

DATE APPLICATION CONSIDERED _____

COMPLETE: _____

TOWN OF TILLSONBURG

SITE PLAN APPROVAL APPLICATION FORM

The undersigned hereby request the Town of Tillsonburg to consider a Site Plan Control application pursuant to Section 41 of the Planning Act on the lands hereinafter described.

Type of Site Plan Approval Application: **Fees include 2 Submissions, Site Plan Approval Fee (includes Registration on Title), Engineering Inspection Fees (applied twice) and Oxford County Works Review fee subsequent submissions-\$515.00 Engineering Inspection Fee- \$ 175.00	<input type="checkbox"/> Amendment to Existing Site Plan Approval (\$1700.00)
	<input type="checkbox"/> Amendment to Existing Site Plan Approval – After (\$2250.00)
	<input type="checkbox"/> Minor Site Plan Approval Application (\$1950.00)
	<input type="checkbox"/> Minor Site Plan Approval Application –After (\$2500.00)
	<input type="checkbox"/> Major Site Plan Approval Application (\$2700.00)
	<input type="checkbox"/> Major Site Plan Approval Application – After (\$4000.00)

1. **BACKGROUND INFORMATION**

a) **Applicant/Agent:**

Name _____

Address _____ City: _____

_____ Postal Code _____

Contact Person E-mail: _____

Telephone Number _____ Fax Number _____

b) **Registered Owner: (if other than applicant)**

Name _____

Address _____ City: _____

_____ Postal Code _____

Contact Person E-mail: _____

Telephone Number _____ Fax Number _____

Solicitor:

Name _____

Address _____ City: _____

_____ Postal Code _____

Contact Person E-mail: _____

Telephone Number _____ Fax Number _____

c) Location of Subject Land:

Lot Number(s) _____ Plan No. or Concession _____

Part Number(s) _____ Reference Plan _____

Lot Number(s) _____ Registered Plan _____

Street Address (or 911 Number) _____

The subject land is located on the _____ side of the street between _____ and _____.

Assessment Roll Number: _____

d) Adjacent Lands:

Does the Registered Owner own any adjacent lands or lands within 120 m of the subject lands? Yes (where) _____ No _____

e) New Development _____ or Expansion of Existing Development _____

If new, is any demolition of existing buildings on the site proposed? Yes ___ No _____

Are there previous site plan or development agreements registered against these lands?

Yes ___ (File no. _____) No ___

f) Existing use of Subject property

g) Proposed uses of land and buildings

h) Official Plan Designation

Schedule “ -1” Land Use Plan _____

Schedule “ -2” Residential Density Plan _____

Other Schedules and Appendices _____

If related to a recent or current Official Plan Amendment application, please indicate the:

File No. _____ Status _____

i) Zoning By-law

Existing Zoning _____

Requested Zoning _____

If related to a recent or current Zone Change application, please indicate the

File No. _____ Status _____

FILES NOT AS SHOWN

2. SITE INFORMATION

Note: Under Parts 2(a) and 2(b) below, where the proposed dimension / feature does not meet the By-law regulation, a Minor Variance(s) or Zoning By-law Amendment will be required. A decision on the Site Plan application cannot be made without first securing approval of the required Minor Variance(s) or Zoning By-law Amendment.

a)	Zoning Provisions	<u>REGULATION</u> by Zoning By-law 3295	<u>PROPOSED</u>
	Lot Frontage	_____	_____
	Lot Depth	_____	_____
	Lot Area	_____	_____
	Lot Coverage	_____	_____
	Front Yard	_____	_____
	Rear Yard	_____	_____
	Interior Side Yard	_____	_____
	Exterior Side Yard (corner lot)	_____	_____
	Landscaped Open Space (%)	_____	_____
	No. of Parking Spaces	_____	_____
	No. of Loading Spaces	_____	_____
	Width of Planting Strip	_____	_____
	Driveway Width	_____	_____
	Handicap Spaces	_____	_____

5 Off-Street Parking and Loading Facilities

Total number of off-street parking spaces existing: _____

Number of off-street parking spaces proposed (include existing & proposed): _____

Number of off-street loading facilities existing: _____

Number of off-street loading facilities proposed (include existing & proposed): _____

b) Proposed Building Size:

Ground Floor Area of Existing Buildings(s) _____

Ground Floor Area of Proposed Development _____

Total Ground Floor Area (including existing & proposed) _____

Number of Storeys proposed _____

Building Height Proposed _____

Total Gross Floor Area Proposed (including existing and proposed) _____

3. COMPLETE AS APPLICABLE

Note: If the application includes a combination of residential, commercial, industrial, institutional or open space development on the same site, the applicable sections must be completed.

a) Multiple Family Residential

Landscaped Area _____ m² (or ft²)

Conversion or Addition to Existing Residential Buildings Yes _____ No _____

Amenity and/or Children's Play Area Yes _____ No _____

UNIT BREAKDOWN

Type	Number of Units	Floor area of Unit Type (m ² or ft ²)
Bachelor	_____	_____
One-Bedroom	_____	_____
Two-Bedroom	_____	_____
Three-Bedroom	_____	_____

Other Facilities provided (e.g. play facilities, underground parking, games rooms, swimming pool, etc.) _____

b) Commercial / Industrial Uses

Describe Type of Business Proposed _____

No. of Buildings Proposed _____

Conversion or Addition to Existing Building Yes _____ No _____

If yes, describe _____

Gross Floor Area (breakdown by type of use - office area, retail, storage etc.) _____

Seating Capacity (if applicable) _____

Number of employees - Initially _____ In future (5 yrs) _____

Open Storage Required Yes___No _____

If yes, describe type, location, area m² (ft²) and buffering provided (if any) _____

Phasing of development/construction if any _____

If residential use proposed as part of, or accessory to commercial/industrial use, please complete Sec. 3 a).

c) Institutional, Open Space or Other Uses

Proposed Use _____

No. of Beds (if applicable) _____

Gross Floor Area by Type of Use (office, common rooms, storage, etc.) _____

Landscaped Area _____ m² (ft²).

FILES SAMPLE NOT AS SHOWN ONLY

4. CHECKLIST TO ENSURE COMPLETE APPLICATION

In order to ensure applications for Site Plan Control are complete please complete the following checklist of the information to be provided on the site plan drawing.

- Site plan at a maximum scale of 1:200 and a minimum scale of 1:300.
- All measurements must be in metric.
- Location/key map at a 1:2000 scale with north arrow.
- Applicant's and owner's name, address and telephone number.
- Project name, municipal address and legal description (Lot and Plan number).
- Professional stamps- Originals
- Property dimensions certified by an Ontario Land Surveyor.
- Site Plan and Building Statistics:
 - Zoning Category / Symbol
 - Lot Area
 - Lot Coverage – proposed and permitted
 - Gross Floor Area – proposed and required
 - Gross Leasable area (if applicable)
 - Landscaped Open Space Area – proposed and required
 - Paved Area
 - Parking spaces – proposed and required
 - Loading spaces
 - Accessible parking spaces provided
- All bearings and dimensions of the property.
- Adjacent land uses, zoning and existing structures.
- Adjacent street names.
- Above ground utilities.
- Existing and proposed services.
- Existing municipal sidewalks.
- Dimensions of all buildings and structures.
- Building setbacks to lot lines and rights-of-way (including overhead canopies).
- Centre line setback of buildings from Arterial roads.
- Existing and proposed easements, rights-of-way and site triangles.
- Location and dimensions of required parking spaces, aisles & loading spaces.
- All vehicular entrances (widths and radii).
- Dimensioned landscape amenity areas.
- Existing and proposed grades around the perimeter of the site and critical points within site, including the base of existing trees to be preserved.
- Finished floor elevations of existing and proposed buildings.
- Retaining walls (top and bottom of wall spot elevations, material).
- Building entrances, including spot elevations at entrances to indicate flush thresholds,.
- Principle building entrance including nearest fire hydrant.
- Existing natural features and vegetation.
- Type and location of all hard surface areas – walkways, stairs, ramps.
- Garbage storage and handling areas.
- Snow removal and storage areas.
- Sign locations and heights.
- The location and turning radii for Fire and Emergency Service access route.
- Completed Appendix 'D' – Cost Estimates for Site Works and Services, if applicable.
- OBC Matrix

Signature of Owner/Applicant

5. AUTHORIZATION

NOTE: The property owner or the authorized agent must complete the application. Where an agent is making the application, the written authorization of the owner must be completed below. If the application is being made under an agreement of purchase and sale, a copy of the agreement must be attached and will remain confidential.

Authorization of Owner(s) for Applicant/Agent to Make the Application

I/We, _____, am/are the owner(s) of the land that is the subject of this application for site plan and I/we authorize _____, to make this application on my/our behalf.

Signature of Owner(s)

DATED

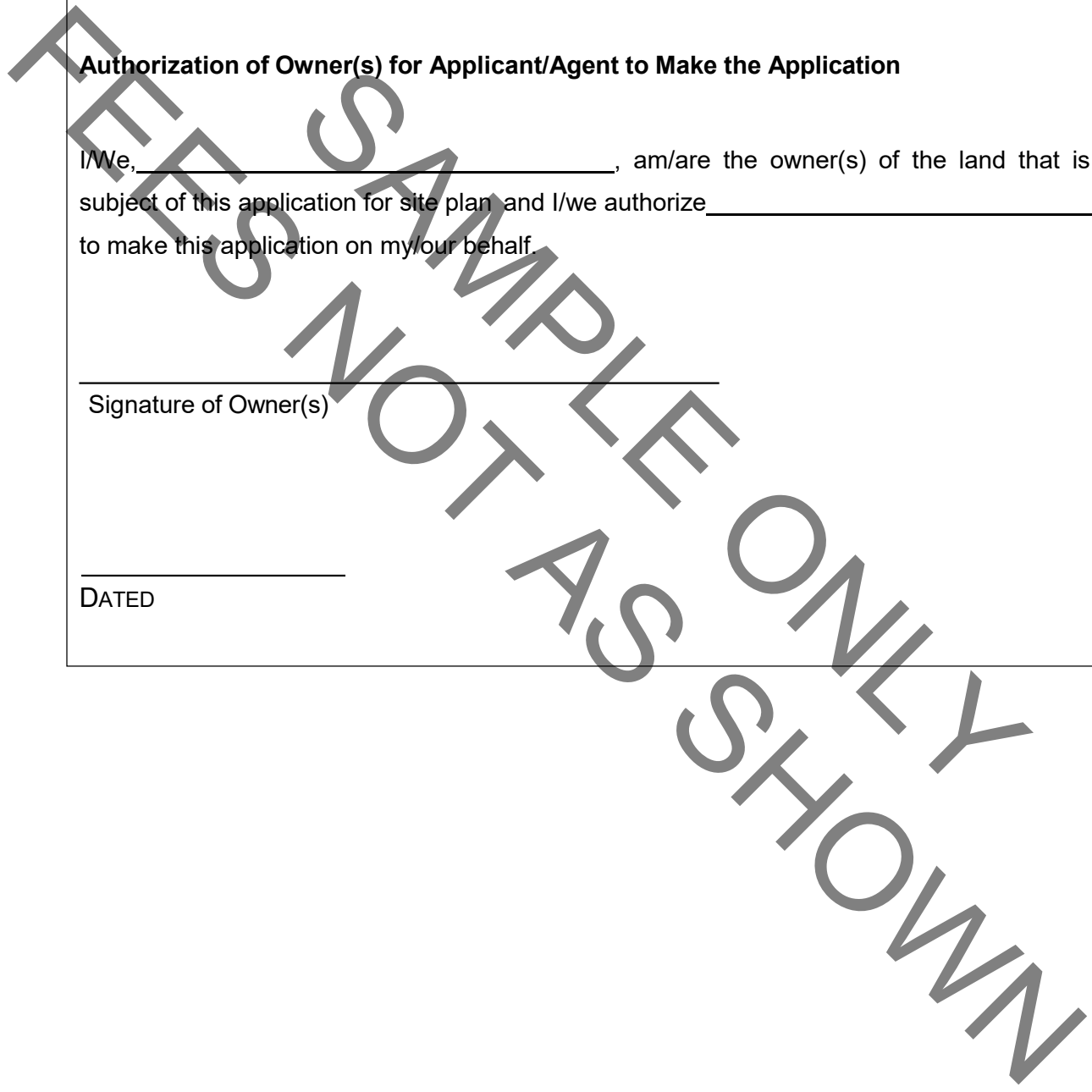

5. DECLARATION:

I/We, _____ of the _____ of
(Name) (Town/City)
_____ in the _____ of _____
(Name of municipality) (County) (Name of County)

DO SOLEMNLY DECLARE THAT:

All of the statements contained in this application are true and I make this solemn declaration conscientiously believing it to be true and knowing that it is of the same force and effect as if made under Oath and by virtue of the Canada Evidence Act.

Signature of Owner/Applicant

DECLARED before me at the _____ of _____
(Town/City) (Name of municipality)
in the _____ of _____
(County) (Name of County)
this _____ day of _____, 20____.

A Commissioner for Taking Affidavits, etc.

Section 4 - Appendix "4-3"
Cost Estimate of Site Works and Services

APPENDIX "D" – COST ESTIMATE OF SITE WORKS AND SERVICES

COST ESTIMATE OF ON-SITE WORKS AND SERVICES		
1.	Site grading and preparation	\$
2.	Paving – granular base and sub base	\$
3.	Paving – base and surface asphalt	\$
4.	Lighting (as applicable)	\$
5.	Fencing	\$
6.	Walkways	\$
7.	Curbing	\$
8.	Waterlines	\$
9.	Sanitary sewers	\$
10.	Storm sewers	\$
11.	Landscaping	\$
12.	Total of other works and services (Please list on a separate page)	\$
TOTAL ON-SITE WORKS AND SERVICES		\$
(A)	TOTAL ON-SITE WORKS AND SERVICES multiplied by 50% or 100% (see page 12 for more detail)	\$
(B)	ON-SITE STORMWATER MANAGEMENT FACILITY (AS APPLICABLE) X 100%	\$
COST ESTIMATE OF OFF-SITE WORKS AND SERVICES		
1.	Water lines and hydrants	\$
2.	Sanitary sewers	\$
3.	Storm sewers	\$
4.	Other works and services (Please list on a separate page)	\$
(C)	TOTAL OFF-SITE WORKS AND SERVICES X 100%	\$
LETTER OF CREDIT IN THE AMOUNT OF THE ABOVE TOTAL (A + B + C)		\$

Signature and Stamp of Professional Engineer



SITE PLAN SUBMISSION REQUIREMENTS
Operations Services
The Corporation of The Town of Tillsonburg
Development Guidelines and Design Criteria

Section 5



Table of Contents

5	SITE PLAN SUBMISSION REQUIREMENTS.....	1
5.1	General Requirements	1
5.2	Application	1
5.3	Fees, Performance Securities and Deposits	1
5.3.1	Fees	1
5.3.2	Performance Securities	1
5.3.3	Deposits.....	3
5.4	General Requirements for Drawings	3
5.5	Drawings Required for Stamping.....	3
5.6	Site Plan Drawing Requirements.....	3
5.7	Building Elevation and Cross-Section Drawings	4
5.8	Landscape Plan Requirements.....	4
5.9	Excess Soil Management Plan.....	4
5.10	Fire Department Access.....	5
5.11	Road Widening(s) and Site Triangle(s).....	5
5.12	Easements.....	5

List of Tables

Table 1. Performance Securities

5 SITE PLAN SUBMISSION REQUIREMENTS

5.1 General Requirements

The purpose of this Manual is to provide submission requirements for the developer and its engineering consultants required for project acceptance for Site Plan Control by the Operations Services of the Town of Tillsonburg.

5.2 Application

The property Proponent or their authorized agent should complete the SPA application found in Appendix "4-2" in Section 4. Where an agent is making the application, the written authorization of the Proponent must accompany the application. If the application is being made under an agreement of purchase and sale, a copy of the agreement must be attached and will remain confidential. Drawings which accompany a site plan application are required to be submitted in standard .pdf format to planning@tillsonburg.ca.

The application must be accompanied by the required fee payable in cash or cheque made to the "Town of Tillsonburg".

5.3 Fees, Performance Securities and Deposits

In accordance with the Town Site Plan Control By-law, a Proponent may be required to provide the Town with an irrevocable, renewable letter of credit, certified cheque, or development bond to ensure satisfactory provision and maintenance of the building, structures, facilities and work approved under the SPA process.

5.3.1 Fees

The required application fee shall be submitted payable to the "Town of Tillsonburg." Please refer to the Rates and Fees By-Law, as amended, for the application fee amount.

5.3.2 Performance Securities

The Proponent shall provide performance securities (in the form of an irrevocable, renewable letter of credit, certified cheque, or development bond) and applicable deposits before the Town issues SPA for the proposed development in the following manner:

Table 1. Performance Securities

For all lands zoned Industrial, Commercial, Open Space or Institutional (excluding retirement homes, nursing homes, etc)	
<u>On-Site Works</u>	
Grading and drainage, seeding, maintenance, erosion control, fencing	50%
Stormwater management facilities	100%
For all lands zoned Residential or Institutional (pertaining to retirement homes, nursing homes, etc)	
<u>On-Site Works</u>	
Grading and drainage, asphalt, curbing, servicing, etc	100%
Landscaping	100%
Stormwater management facilities	100%

The performance security required for all work proposed within the Town or County road allowance, or on Town/County owned land, shall be at 100% of the cost estimate provided by the Proponent’s consulting Engineer to the satisfaction of the Town of Tillsonburg.

The performance security shall also contain 1.76% net non-rebatable HST.

Further to the above, the Town will not require performance securities in the event that the Proponent’s submitted cost estimate (to the satisfaction of the Town Engineering Services), indicates the required performance security will not exceed \$5,000.00.

Also, the Town will not require performance securities relating to stormwater management in the instance where a Town owned regional stormwater management facility has already been constructed. However securities will be required for dredging the storm water management pond.

The amount of the performance securities required by the Town shall be listed in the Site Plan Agreement. Any construction on Town property or the use of public right of ways during construction must be first approved by the Town through the SPA process and outlined in the Site Plan Agreement. Any construction on Town or County properties or road allowances shall require an encroachment permit prior to the commencement of any approved construction.

In order to determine the amount of the performance securities required by the Town, the Proponent’s consulting Engineer must complete Appendix “4-3” – Cost Estimate of the Site Works and Services found in Section 4 and affix their professional stamp.

5.3.3 Deposits

A deposit may be required for a third party peer review of site servicing, grading and storm water management, noise and vibration, and traffic impact, etc. as determined by Town staff. If the collected deposit does not cover the cost of the third party review, the Proponent will be required to pay for any additional/outstanding fees to the Town prior to SPA. Alternatively, any monies from the deposit remaining after the third party review will be returned to the Proponent upon SPA.

5.4 General Requirements for Drawings

The completed application form shall be accompanied by a site plan drawing(s). At a minimum, the drawings used to describe the proposed development will show the site details, landscaping, storm water management, services and grading. Additional separate drawings showing the landscape plan, site servicing plan, building elevations and cross section plans shall also be submitted.

Three (3) full size (maximum size of 24"x 36") folded copies of the site plan drawing(s) are required, including digital .pdf copies of the full size drawings. These drawings shall be prepared by a qualified professional in such a manner as to permit registration at the Oxford County Land Registry Office. Please refer to the SPA Pre-consultation application (Appendix "4-1") in Section 4 to verify the applicable professional required to prepare the SPA drawings.

5.5 Drawings Required for Stamping

Once SPA has been granted, three (3) sets of large drawings, a digital .pdf of the final plans shall be submitted to be included in the Site Plan Agreement or Undertaking. Final plans for SPA shall be certified by the appropriate professional. The drawings and plans submitted for review must meet the requirements set out in this document.

5.6 Site Plan Drawing Requirements

The general site plan requirements are listed in checklist format in SPA application (Appendix "4-2") and are required as a minimum submission for SPA. Further details are listed below. All submitted drawings are required to be in black and white only unless otherwise specified in these Guidelines. Also, please see the completed SPA Pre-consultation application for clear guidance regarding required drawings/reports/studies/etc.

5.7 Building Elevation and Cross-Section Drawings

Building elevation and cross section drawings are required for all commercial, industrial, institutional buildings and residential buildings containing more than four units. These drawings must include the following details:

- Drawing scale
- Elevation and details of all facades of the building including type of surface material and paint colour schemes
- All windows, doors, openings and any mechanical equipment attached to or on the roof of the building including the dimensions of these features
- A longitudinal cross-section view through the building to the street line
- Elevations and dimensions of any signs on the building. If a freestanding sign is proposed, an insert drawing is required with the details of the sign

5.8 Landscape Plan Requirements

The landscape plan(s) must encompass the same area of the site plan and must include:

- The location of all existing and proposed trees and/or shrubs which are to be preserved or removed. The symbol of each tree/shrub must reflect the branch spread or canopy of existing trees/shrubs and the proposed trees/shrubs at maturity
- A landscaping table listing all existing and proposed species, including common name, botanical name, quantity, size and condition at planting
- Planting specifications and any required instructional drawings
- All areas to be seeded or covered in grass sod and calculated area thereof, in addition to the percent coverage for the site

Please refer to Section 15 which lists, in detail, the Landscape Plan Guidelines.

5.9 Excess Soil Management Plan

An Excess Soil Management Plan shall be prepared by a Qualified Person, as defined by Ontario Regulation 153/04, for proposed developments that require excess soil to be removed from site and meets the criteria of current Ontario regulations. The purpose of the report is to characterize the quality of the excess soil and generate a management plan that is in compliance with the current Ontario regulations for excess soil management.

The Plan shall be prepared as per the MOE's "Management of Excess Soil – A Guide for Best Management Practices" and shall comply with the current regulatory implementation schedule as put forth by the MOE.

The Excess Soil Management Plan shall be submitted to the Town of Tillsonburg for approval. If deemed appropriate by the Town, the Town may appoint a qualified third-party reviewer to review

the plan for compliance to the current regulatory obligations. The owner shall be responsible for the cost of the third-party reviewer.

The Owner will be responsible for O.Reg 406/19 ON-SITE AND EXCESS SOIL MANAGEMENT

5.10 Fire Department Access

Access to buildings for emergency services as required by the Ontario Building Code, shall be shown on the site plan.

5.11 Road Widening(s) and Site Triangle(s)

All road widening(s) and site triangles to be dedicated to the Town and/or County are to be shown on the site plan. These lands are to be free of buildings, structures and signs. All road widening(s) and site triangles will be deeded free and clear of all legal encumbrances to the Town. Any costs associated with the dedication of road widening(s) and site triangles are to be incurred by the Proponent.

5.12 Easements

An easement provides the right to use private land for a specific purpose. A title search prior to developing plans will identify existing easements and their specific use, size and location.

In order for any Town and utility installations traversing the site to be properly installed and maintained by the appropriate authority, Town service easements and utility easements are required for any water mains, sanitary and storm sewers, drains, telephone, electricity, gas and cable services that traverse the site.

The site plan shall show both existing easements and any easements to be granted to the Town, County or applicable utility provider. The easements shall be free of all buildings and structures. The treatment of the easement(s) including the placing of fill, vehicular access and landscaping, shall be with the approval of the Town, County or utility company to which the easement is conveyed.



SITE PLAN ADDITIONAL GUIDELINES
Operations Services
The Corporation of the Town of Tillsonburg
Development Guidelines and Design Criteria

Section 6

Table of Contents

6 SITE PLAN ADDITIONAL GUIDELINES 1

6.1 General Requirements 1

6.2 Other Reference Documents..... 1

6.3 Location of Buildings and Facilities 1

6.4 Building Orientation 2

6.5 Building Form 2

6.6 Parking, Driveway and Loading Facilities Guidelines – All Developments 3

 6.6.1 Parking Areas 3

 6.6.2 Parking Space Requirements..... 3

 6.6.3 Internal Driveways 4

 6.6.4 Off-Street Loading Facilities 4

6.7 Garbage Storage Handling Areas – All Developments..... 4

6.8 Snow Removal and Storage Areas – All Developments..... 5

6.9 Access – All Developments..... 5

6.10 Pedestrian Facilities Guidelines – All Developments..... 5

6.11 Landscaping and Buffering Features Guidelines – All Developments..... 6

 6.11.1 Definitions..... 6

 6.11.2 Screening and Ornamental Plantings 7

 6.11.3 Plant Selection..... 7

 6.11.4 Preservation of Existing Landscape Elements..... 7

6.12 Tree Protection Standards - All Developments..... 7

6.13 Guidelines for Commercial Developments 8

 6.13.1 General Guidelines..... 8

 6.13.2 Commercial Development in the Downtown Core Area 8

6.14 Additional Guidelines for Residential Development..... 9

 6.14.1 General Building Orientation..... 9

 6.14.2 Separation Spaces 9

 6.14.3 Private Outdoor Amenity Areas 10

 6.14.4 Children's Play Areas..... 10

 6.14.5 Proximity to Railway Lines and Other Sources of Noise 10



SITE PLAN ADDITIONAL GUIDELINES
Operations Services
The Corporation of the Town of Tillsonburg
Development Guidelines and Design Criteria

6.14.6	Community Mailboxes	11
6.15	Design for Accessibility	11
6.16	Additional Guidelines and Design Criteria	11
6.16.1	Site Servicing Plan Requirements.....	11
6.16.2	Grading.....	11
6.16.3	Sanitary Sewer Systems.....	12
6.16.4	Stormwater Drainage and Collection	13
6.16.5	Stormwater Management Systems.....	14
6.16.6	Water Systems	14
6.16.7	Waste Water Systems	14
6.16.8	Electrical Systems	15
6.16.9	Site Lighting Guidelines - All Developments	15
6.16.10	Excess Soil Management	15

6 SITE PLAN ADDITIONAL GUIDELINES

6.1 General Requirements

This section outlines the recommended requirements for the design and implementation for the specific objectives for each matter which is subject to Site Plan Control, as well as the guidelines, criteria and standards to be used to achieve these goals.

6.2 Other Reference Documents

Lot grading shall be designed and constructed in accordance with the latest version of this manual as well as other industry standards and best practices, including but not limited to:

- Guidelines on Erosion and Sediment Control for Urban Construction Sites, prepared by Ontario Ministry of Natural Resources
- Ontario Provincial Standard Specifications (OPSS) and Ontario Provincial Standard Drawings (OPSD) prepared by the Ministry of Transportation
- Ontario Building Code (OBC)
- Applicable Town of Tillsonburg By-Laws

6.3 Location of Buildings and Facilities

The objectives of Site Plan Control for building and facility location are to demonstrate the extent to which the massing and conceptual design of new developments:

- Minimize conflicts with adjacent land uses
- Provide a comfortable and pleasing environment for the intended uses in terms of building orientation, form and siting
- Are consistent with or complimentary to existing buildings that are to be retained
- Are consistent with or complimentary to existing streetscapes
- Comply with Zoning By-law provisions
- Manage drainage and lot grading on the subject site and mitigate the effects of development on adjacent properties

6.4 Building Orientation

Objectives for proper orientation of buildings on a development site include the following:

- Where possible, buildings should reinforce the prevailing street pattern by aligning with the established building line or street edge. Buildings may be set back from or placed at an angle to the existing street edge if they are of community importance
- Where possible public views, into, through and out of a development site, should be maintained and improved. Community identity can be achieved by ensuring views of community features such as churches, heritage buildings, bodies of water, valleys, open space and bridges are preserved
- New development next to parks, open space and streets should be designed to effectively integrate with the surrounding landscape so that any change resulting from the new development does not compromise the character of the landscape
- Buildings should be oriented to maximize energy conservation

6.5 Building Form

The scale and character of new development should reflect the existing neighborhood pattern and/or adjacent heritage buildings. The following features of the surrounding neighbourhood should be reflected in the new development:

- Building height
- Ground level treatments
- Ground level views
- Roof treatments
- Frontage widths
- Continuity of street face
- Facades
- Scale of doors, windows and other openings
- Canopies
- Lighting and
- Landscaping

The form created by the building should produce a sense of physical security by controlling ingress and egress as well as providing visual surveillance of all public or common areas.

The Proponent is encouraged to consider aesthetic characteristics of adjacent development and incorporate similar features into the design of new buildings and structures such as:

- The compatibility of materials, textures and colours
- The unique architectural details such as cornices, railings, lintels, arches, ironworks and chimneys

6.6 Parking, Driveway and Loading Facilities Guidelines – All Developments

The requirements for parking surface material, space size and number, aisle and driveway widths and loading facilities are to comply with Sections 5.14, 5.24 and all other applicable provisions of the Town of Tillsonburg Zoning By-law, as amended.

6.6.1 Parking Areas

To ensure appropriate design for vehicle access and loading, all parking spaces are to be painted with lines to delineate the location and size of spaces. Consideration may be given to alternative surface materials such as cobblestone which allow precipitation to percolate into the soil, for any parking spaces provided over the minimum number required.

To ensure adequate parking areas have orderly circulation and an attractive community appearance:

- Delineate parking rows to confine traffic to designated parking aisles or driveways
- Minimize access to and from parking aisles along main internal driveways
- Design and clearly mark all accessible parking in accordance with Section 5.24.2.2 of the Town Zoning By-Law
- Clearly identify the types of designated parking areas for employees, visitors and the public
- Ensure public parking does not conflict with shipping, loading, garbage removal or utility areas
- Ensure parking is not the dominant visual element in the streetscape. Screen larger parking areas with buildings, landscaping or low walls, while still maintaining some visibility to provide public safety by means of public surveillance

6.6.2 Parking Space Requirements

As previously mentioned, requirements for the number of parking spaces for specific types of uses and the size of spaces are set out in the Town Zoning By-law, Section 5.24.

The number of parking spaces designated to accommodate persons with disabilities shall be in accordance with Section 5.24.2.2 of the Town of Tillsonburg's Zoning By-law.

6.6.3 Internal Driveways

To ensure proper flow of traffic:

- Delineate main internal driveways with raised curbs
- Avoid lengthy straight sections and use traffic calming devices to discourage high speeds
- Ensure adequate visibility of intersecting traffic movements in the design of driveways and parking aisle intersections
- For large commercial or industrial developments, main internal driveways should be located away from building entrances in order to minimize pedestrian and vehicle conflicts
- Aisles designed for one-way or two-way circulation should be clearly marked
- Driving lanes should widen at drop-off areas near buildings
- Turning radii shall be provided at the end of dead-end driveways
- Identify and design all required fire routes as per the Ontario Building Code and National Fire Code

6.6.4 Off-Street Loading Facilities

To ensure loading facilities are effective:

- Sufficient space should be provided on a property to permit delivery vehicles to make all maneuvers "off-street" away from fire routes which are to be designed to support emergency vehicles
- Separate access or internal driveways should provide access to loading facilities which abut the building to be served
- For commercial developments or other integrated development, the use of joint loading facilities to serve all or several individual businesses will be encouraged

Site Plan designs should ensure that adequate waste storage facilities and enclosures are provided to permit:

- The storage of garbage and recyclable materials between collections thereby avoiding health, safety, and litter problems
- The efficient and safe collection of garbage by collection vehicles
- Adequate separation from other land uses including residential uses

6.7 Garbage Storage Handling Areas – All Developments

To ensure proper design and siting of waste storage facilities include the following:

- Location and accessibility – waste disposal areas should be located at the building service entrance or rear yard which can be easily accessed by the waste collection vehicle

- Collection Platform Material – a concrete pad or other structurally adequate impervious material is required to mitigate any seepage of liquid waste
- Enclosure Wall Material and Height – the enclosure should be constructed with low maintenance durable material
- Street-fronting Townhouses should have an individual waste and recycling storage area within or immediately associated with each unit. Common exterior storage facilities are not recommended and will only be permitted where the Proponent demonstrates that individual storage facilities are not feasible
- Apartments – waste and recycling is to be centrally stored in specifically designed common storage facility

6.8 Snow Removal and Storage Areas – All Developments

To ensure proper snow removal and storage areas, include the following:

- Location of snow storage – snow storage areas should be identified on the site plan outside of a parking area, garbage storage and pedestrian access to the building. Appropriate grading shall be provided to manage snowmelt
- Design – parking areas, outdoor amenity areas, and pedestrian access ways should be designed to ensure accessibility of snow removal equipment

6.9 Access – All Developments

To ensure the orderly and safe movement of traffic with minimum interference with pedestrian traffic:

- The number of access driveways shall be minimized
- Individual residential driveways on to arterial streets should be avoided
- Access for development on a corner lot should be as far from the intersection of the two streets as possible
- Where required, the site plan shall make provisions for the joint use of common driveways between abutting properties

Please note that a Traffic Impact Study may be required to be submitted as part of the SPA application. Further, a deposit may be required to have the study peer reviewed.

6.10 Pedestrian Facilities Guidelines – All Developments

To ensure the provision of safe and convenient pedestrian circulation:

- Install public sidewalks across the frontage of the site in accordance with the Town standards. Please review the Town of Tillsonburg Development Guidelines and Design Criteria or contact the Town of Tillsonburg for the required public sidewalk standards
- On-site walkways should join building(s), access points to parking areas, recreational areas and public sidewalks

- Link building entrances to sidewalks and parking areas by means of a safe, convenient and well-lit walkway system
- Clearly identify walkways that cross vehicular lanes
- Provide continuous pedestrian walkways between entrances of units in buildings with multiple tenancies
- Increase the width of the walkway where pedestrian activity is greater, such as at building entrances
- Protect pedestrian areas from vehicular intrusion with landscaping or curbs
- Minimize grade changes between the public sidewalk and private pedestrian areas
- Design pedestrian facilities for maximized accessibility from the public sidewalk to, at least, one main building entrance and one main parking area by incorporating sidewalk ramps of a proper gradient and surfacing material. Compliance with the Ontario Building Code will be required
- Recommended standards are outlined in the Built Environment Standard of the AODA

Notwithstanding the above, sidewalks shall not be required to be constructed in Restricted Industrial (MR) and General Industrial (MG) zones, unless existing sidewalk networks exist in the vicinity of the proposed development. If a sidewalk network is present within the vicinity of the proposed development, the Proponent shall contact the Town Director of Operations and Development in order to discuss required sidewalk construction and connection to the existing sidewalk network.

6.11 Landscaping and Buffering Features Guidelines – All Developments

The following landscaping design requirements may be required on the landscape plan at the discretion of Town staff.

Landscaping requirements, in the form of planting strips, are outlined in Section 5.25 Planting Strips of the Town of Tillsonburg's Zoning By-law and must be shown on the Site Plan or if required, a separate Landscape Plan.

6.11.1 Definitions

For the purposes of these guidelines, the following definitions are applicable:

- "Landscaping" is comprised of deciduous and/or coniferous trees, shrubs, organic and herbaceous ground cover, berms, water courses, retaining walls, fences, outdoor furniture, and other materials or objects that may be used to enhance the function and/or aesthetics of the landscaped area.
- "Landscaped Open Space" - means the open unobstructed space at grade on a lot and which is suitable for the growth and maintenance of grass, flowers, bushes, trees and other landscaping and includes any surfaced walk, patio or similar area but does not include any driveway or ramp, whether surfaced or not, any curb, retaining wall, parking

area or any open space beneath or within any building or structure. (Section 4.97 of the Town of Tillsonburg's Zoning By-law).

6.11.2 Screening and Ornamental Plantings

The two basic types of landscaping are "Screening" and "Ornamental Planting." The function of each type overlaps. Screening can also be Ornamental and vice versa. Screening and ornamental plantings can include items such as plants, hedges, walls, fences, berms and herbaceous or organic ground cover.

6.11.3 Plant Selection

Native plant species are strongly encouraged wherever feasible. The selection of landscaping and plant material shall be based on the following criteria:

- Year round and seasonal Interest
- Colour
- Height and shape of planting through to maturity
- Maintenance – fertilizing; pruning and watering; plants that drop large seed pods or shrubs with thorns or sharp edges shall be planted away from pedestrian walkways
- Function - wind protection, seasonal shading and vandal resistance
- Physical Conditions - proximity to buildings in terms of shadow and obstruction of sunlight; roads and vehicular access ensuring sight lines are not obstructed and salt spray and snow storage areas do not damage plantings; and Town services and utilities ensuring root systems do not obstruct utilities above or below ground
- All plants will be certified by a landscape architect

6.11.4 Preservation of Existing Landscape Elements

Consideration should be given to the preservation, retention and improvement of existing landscape elements such as major trees and watercourses.

6.12 Tree Protection Standards - All Developments

Tree preservation and protection is encouraged through careful site planning including the appropriate location of buildings, facilities and servicing. In general, when trees are to be saved in a construction area, the following recommendations have to be followed to ensure the longevity of those trees:

- Where deemed necessary, a tree preservation report will be required and prepared by a qualified professional. This report shall include detailed tree inventories, assessments, discussion of alternatives and recommendations
- A snow fence or other barrier should be placed around the tree to at least the "drip line" of the tree. The "drip line" is the outer extent of branches, regardless of tree maturity

- No excavation shall be carried out within the "drip line" of trees to be preserved. Root loss must be minimal
- No heavy equipment shall be driven over the tree lawn area within the drip line, to alleviate soil compaction around the tree roots
- No soil or construction materials shall be piled within the drip line area or around the trunks of trees to be preserved

If comments or questions regarding trees to be saved should arise, the services of the Town's Parks office will be available at 519-842-9200 at any time before or during construction.

6.13 Guidelines for Commercial Developments

In general, commercial uses can have impacts on other more sensitive land uses. New commercial uses and expanding uses must have minimal impacts on nearby sensitive land uses.

6.13.1 General Guidelines

The design should meet the following objectives:

- Ensure new developments are sited such that adjacent properties maintain sunlight exposure, have visual privacy, protection from the new development's lighting, noise, odour and vibration. Screen certain site elements, such as loading areas, snow storage areas, transformers, meters, garbage enclosures and roof-top mechanical equipment from public view
- Avoid building designs with large flat surfaces. Incorporate angles, differing setbacks, peaked rooflines, canopies, and coloured trim to provide interesting, attractive façade(s)
- Provide safe, convenient access for persons with disabilities to all major building entrances by means of minimal grade changes, curb cuts, ramps and railings
- Provide screening and buffering between existing residential uses and new developments

6.13.2 Commercial Development in the Downtown Core Area

Within the Downtown Core Area, locate buildings at the minimum setback line from the street and to a width equal to the maximum frontage of the property to:

- Provide frequent and convenient pedestrian connections between buildings and the public sidewalk
- Provide protection for pedestrians from inclement weather with shelters, canopies and windbreaks at building entrances and along storefront facades
- Minimize the public view of off-street parking areas and servicing facilities

Commercial development within the Downtown Core Area shall reflect the recommendations and guidelines of the Central Area Design Study (2012).

6.14 Additional Guidelines for Residential Development

The following guidelines address residential development proposals which require SPA. As previously mentioned, SPA is required for multi-family (medium and high density) residential types of development.

6.14.1 General Building Orientation

- Consideration should be given to locating residential buildings close to the north lot line to increase solar access to open spaces on the site
- The proposed building(s) should not excessively shade adjacent private or public property. In the case of multiple storey apartment buildings, a shadow study may be required to ensure that adjacent properties are not negatively affected by the proposed development
- The long axis of apartment buildings and multiple residential buildings should be oriented to ensure that most of the dwelling units would receive sunlight during some part of the day
- Residential buildings exceeding 4 storeys should be sited with one of the longest walls parallel to and not more than 6.0 m (20 feet) from a driveway that can accommodate fire equipment

6.14.2 Separation Spaces

Separation spaces generally refer to the space between buildings on the same site. Setbacks refer to the space between a building and the street line or property line. Separation spaces are also required for fire protection under the Ontario Building Code. Separation spaces between buildings and property lines should address:

- Sunlight - Space should be provided around dwellings to ensure the provision of daylight. New housing should be located so not to deprive existing dwellings and private outdoor spaces in the surrounding areas of adequate sunlight or daylight
- Ventilation - The space around the unit should be sufficient to permit natural ventilation of the dwelling
- Noise and Privacy - Physical separation and/or screening should be provided between the dwelling unit and adjacent users and activities to permit the occupant to enjoy rest and privacy without undue interference from external noise. Windows and entrances of a dwelling unit should be separated and/or screened from adjacent buildings and activities to permit residents to make full use of their interior living spaces
- Application of Separation Space - The minimum separation space in front of any window or opening should be applied along the full length and height of the exterior wall. Separation spaces should be free of buildings, roadways, communal parking areas and any communal amenity areas intended for active use

6.14.3 Private Outdoor Amenity Areas

Private Outdoor Amenity Areas are intended to provide private outdoor areas directly related to the dwelling unit that can effectively extend the living area of the unit and may include landscaped open areas, patios, balconies, communal lounges, swimming pools, recreation facilities and any other areas which may be used for recreational or aesthetic purposes. Outdoor amenity areas shall not include any driveway or parking area. Private outdoor amenity areas should address:

- Type of Occupancy - The amenity space should reflect the anticipated type of households that will occupy the dwelling units
- Accessibility - For ease of maintenance, an on-grade private outdoor space should be accessible from the front of the unit without requiring access through a living or dining room. A private outdoor space above grade should be easily accessible from a principle habitable room such as a living room
- Separation and Screening - Separation, in the form of distance or separation screening, between private outdoor spaces and adjacent uses should be provided. Where screening is used to provide separation between abutting privacy areas at the same grade, this screening should be at least 1.5m (5.0ft) high
- Parking Separation - Common parking lots should not be closer than 3.0m (9.8ft) to a private outdoor space and should be oriented so that headlights and fumes are not directed towards the private outdoor space by using a parallel parking arrangement or by screening with planting or fencing

6.14.4 Children's Play Areas

All multi-family residential developments shall have an area set aside within the site for the exclusive use by children as a play area. This play area shall consider the following factors in the design:

- The area shall be located away from parking areas, driveways and garbage bins. If located adjacent to a property line, the area shall be fenced with a six foot privacy fence
- The areas shall be level and be landscaped with grass and perimeter trees

6.14.5 Proximity to Railway Lines and Other Sources of Noise

Proponents may be required to provide, in conjunction with site plans, an acoustical engineering study outlining on-site noise and vibration measurements, methods of evaluation, noise sources and abatement measures. New residential development which is proposed to locate in proximity to railway lines or other major sources of noise will be required to meet Provincial Noise Guidelines for residential development to ensure an acceptable acoustical environment is provided for future occupants. Where noise abatement measures are required, site plans and/or landscaping plans shall incorporate the necessary remedial measures.

The Proponent will be responsible for any costs associated with having the study reviewed by an independent acoustical engineer on behalf of the Town.

6.14.6 Community Mailboxes

Community mailboxes are to be located according to the following criteria:

- In areas which are satisfactory to Canada Post and the Town
- In areas which reduce the potential for conflict with surrounding properties
- In areas that provide a suitable location for the temporary parking of automobiles and on a portion of the Town road allowance which has been widened slightly to recognize the location of the mailbox
- In a visible and well lit area that provides a sense of security
- For townhouse developments, within a common element area that is easily accessible to all dwelling units and, preferably, protected from the natural elements

6.15 Design for Accessibility

In accordance with the Accessibility for Ontarians with Disabilities Act, 2005 the Town aims to make all buildings accessible to persons with disabilities. This new act will be progressively implemented to replace the existing ODA. The legislation will apply to all private and public sector organizations and businesses with the release of five standards relating to accessibility with respects to goods, services, facilities, employment, accommodation and buildings. All site plans shall be required to adhere to the standards released under the Act, and any accessibility requirements of the Town Zoning By-Law and Ontario Building Code.

Site plans shall incorporate design features that will make all facilities accessible. Indoor and outdoor design of facilities shall be made safe and convenient by minimizing grade changes and providing such things as disabled parking spaces, suitable curb cuts, tactile plates, ramps and hand-rails.

6.16 Additional Guidelines and Design Criteria

6.16.1 Site Servicing Plan Requirements

The Town of Tillsonburg Development Guidelines and Design Criteria and Oxford County Design Standards are to be adhered to when designing any new developments within the Town. The guidelines can be obtained by either visiting the Town's website or by contacting the Town of Tillsonburg Engineering Services for a copy of these guidelines. The site servicing plan must also include details of all water, sanitary sewer, storm drainage, and electricity systems. The Oxford County Design Standards are available online on the Oxford County website.

6.16.2 Grading

Proper grading and disposal of storm and surface should be constructed in order to optimize:

- Safe, convenient and functional access for pedestrians and vehicles to all areas of the site
- Preservation of the natural features of the site where feasible

- The prevention of stormwater from entering the sanitary sewer system
- Proper site drainage such that stormwater is contained within the site and directed to an internal storm drainage system, thereby preventing drainage onto adjacent properties

All designs for the conveyance of storm and surface water are to be prepared by a qualified professional. When deemed necessary by the Town, these designs are to be certified and the drawings appropriately stamped.

Grading shall comply with the Accessibility for Ontarians with Disabilities Act, 2005 as well as Oxford County's Facility Accessibility Design Standards.

The grading design shall be in accordance with Section 14 of these guidelines.

6.16.3 Sanitary Sewer Systems

The sanitary sewer features are to be designed in accordance with the Town of Tillsonburg Development Guidelines and Design Criteria, as well as the Provincial standards (including the Ontario Building Code) and the County of Oxford standards and specifications. Please contact the County of Oxford Public Works Department at 519-539-9800 for information regarding the County standards and specifications. The following features must be illustrated on the servicing drawing.

- On-site sewer - location from building to private drain connections, size and grade
- Private drain connections - existing and new, location, size and grade
- Control manholes to be located at the street line on private property and shall remain the responsibility of the owner to maintain
- All manholes must show invert and finish grade elevations
- Ministry of Environment requirements - "private sewers" are to be designed generally in accordance with Guidelines for the Design of Sanitary Sewage Works, Systems, Storm Sewers (interior), Water Distribution Systems and Waste Storage Facilities
- Location and capacity of existing and proposed septic tank(s) and tile bed(s) on the property, if Town sanitary sewers are not available

6.16.4 Stormwater Drainage and Collection

The storm drainage features are to be designed in accordance with the Town of Tillsonburg Development Guidelines and Design Criteria and Long Point Region Conservation Authority standards and specifications. For information regarding the Conservation Authorities' requirements, please visit the Long Point Region Conservation Authority websites at www.lprca.on.ca. For lands abutting County road allowances, storm drainage features are to be also designed in accordance with County standards. Please contact the County Public Works Department at 519-539-9800 for information on the County standards. The following features must be illustrated on the servicing drawing:

- Catch basins - locations, proposed elevations for grates and inverts
- Drainage piping location and all access hole inverts and final grade elevations from building to private drain connections
- Private drain connections - existing and new, location, size and grade, drainage swales (landscaped areas) - elevations along swale, cross sections % grade (slope)
- Overland flow - show flow arrows to permit ready identification of overland flow direction, show existing and proposed elevations along property lines, and key points on site and abutting properties
- Flows from adjacent properties - in the event that adjacent private properties drain onto the site being developed, the storm drainage system is to be designed to prevent stormwater from backing up and creating a flooding or ponding condition on the adjacent property
- Weeping tiles - identify how flows will be handled should weeping tiles be installed
- Stormwater management systems display such relevant detail contained in the consulting Engineer's design as will be necessary to ensure that these features are implemented by the contractor
- Surface ponding shall not exceed 0.15m in depth at any location
- Sediment and erosion control measures to be implemented before and during construction and post-construction
- Stormwater management systems and design

Depending on the site and scale of the development, a stormwater management report may be required in addition to the above servicing drawing requirements. New stormwater management ponds will require an Environmental Compliance Approval from the Ministry of Environment and Climate Change.

6.16.5 Stormwater Management Systems

The Proponent shall be required to submit a stormwater management report, prepared by a professional engineer competent in stormwater management and licensed to practice in Ontario. The stormwater management shall be submitted to and approved by the Town and shall follow the stormwater management practices within the Town of Tillsonburg Development Guidelines and Design Criteria. Each site plan application shall comply with the following:

- Quantity Controls - The flows from a development site are to be controlled to those pre-development flows (green field) or to the allocated flow rate within the R.O.W. storm sewer servicing the site
- Quality Controls – For all residential, commercial, institutional and industrial developments, the Town requires Enhanced Water Quality Protection (80% Total Suspended Solids Removal) as described in the Stormwater Management Planning and Design Manual prepared by the MOE (2003) prior to discharge from the site to the receiving outlet
- Certification by Engineer - Upon completion of construction, the Proponent will be required to have the professional engineer certify that the stormwater management system was constructed in accordance with the approved design
- Surface ponding to be limited to 300mm within parking lots.

6.16.6 Water Systems

The water system features are to be designed in accordance with Provincial, County of Oxford and the Town of Tillsonburg Development Guidelines and Design Criteria standards and specifications. The following features must be illustrated on the servicing drawing:

- Location and size of all existing or proposed water pipes and mains, valves, shutoffs and blow-offs
- Location of existing and proposed fire hydrants in the vicinity which will service the development
- Location of existing and proposed private water wells on the subject property, if applicable

6.16.7 Waste Water Systems

Access cleanouts may be required to permit monitoring by the Town and the County Public Works Department. These access holes shall be displayed specifically on the site plan and shall be located on the private drain connection(s) within the development site at the street line

6.16.8 Electrical Systems

The electrical system features are to be designed in accordance with the electrical distribution authority (Tillsonburg Hydro Inc.) and the Town of Tillsonburg Development Guidelines and Design Criteria standards and specifications. The following features must be illustrated on the servicing drawing:

- Transformer and vault location
- Primary, secondary and service wire and/or cable location
- Service entrance and meter location on any buildings or structures

6.16.9 Site Lighting Guidelines - All Developments

The type, location, height, intensity and direction of lighting shall be shown on the site plan. Lighting should be kept internal to the site and not adversely affect adjacent residential properties, or adjacent public streets, which could pose a vehicular safety hazard. Illumination patterns and levels must be designed to ensure that the site is not illuminated more than necessary. The usage of LED lighting is preferred.

A photometric site plan may be required to demonstrate lighting is entirely contained within the site and zero illumination at property line so that not adversely affecting adjacent residential properties.

All site lighting shall be consistent with the requirements and standards of the Institute of Electrical and Electronics Engineers (IEEE).

6.16.10 Excess Soil Management

An Excess Soil Management Plan shall be prepared by a Qualified Person, as defined by Ontario Regulation 153/04, for proposed developments that require excess soil to be removed from site and meets the criteria of current Ontario regulations. The purpose of the report is to characterize the quality of the excess soil and generate a management plan that is in compliance with current Ontario regulations for excess soil management.

The Plan shall be prepared as per the MOE's "Management of Excess Soil – A Guide for Best Management Practices" and shall comply with the current regulatory implementation schedule as put forth by the MOE.

The Excess Soil Management Plan shall be submitted to the Town of Tillsonburg for approval, if deemed appropriate by the Town, the Town may appoint a qualified third-party reviewer to review the plan for compliance to the current regulatory obligations. The owner shall be responsible for the cost of the third-party reviewer.

The Owner will be responsible for O.Reg 406/19 ON-SITE AND EXCESS SOIL MANAGEMENT

Section 7

Table of Contents

7	ROADWAYS	1
7.1	General Requirements	1
7.1	Other Reference Documents.....	1
7.2	Industry Standards and Specifications.....	1
7.3	Other Applicable Acts and Legislations	1
7.4	Road Classifications.....	2
7.5	Roadway Cross-sections	3
7.5.1	Bike Lanes	3
7.6	Geometric Design Elements.....	3
7.7	Intersections	4
7.8	Cul-de-Sacs	5
7.9	Temporary Roads	5
7.10	Emergency Access	5
7.11	Pavement Design	5
7.11.1	General Requirements	5
7.11.2	Alternative Materials	6
7.12	Concrete Curb	6
7.13	Subdrains	6
7.14	Driveways	7
7.14.1	General Requirements	7
7.14.2	Driveway Materials	7
7.15	Curb Depression	8
7.16	Sidewalks	8
7.16.1	Tactile Surface Warning Plates.....	8
7.17	Location of Utilities.....	9
7.18	Parking	9
7.18.1	Accessibility Parking.....	9
7.19	Topsoil, Seed and Sod.....	9
7.20	Fences and Walls	9
7.20.1	Fences	9
7.20.2	Noise Attenuation Walls.....	10
7.21	Subdivision Entrance Structures	10

List of Tables

- Table 1. Street Classifications - Residential
- Table 2. Geometric Design Elements
- Table 3. Curb Return Radii
- Table 4. Minimum Pavement Design Requirements
- Table 5. Driveway Requirements
- Table 6. Concrete Sidewalk Parameters

7 ROADWAYS

7.1 General Requirements

This section outlines the recommended minimum requirements for the design and implementation of the transportation network and roadways within the Town of Tillsonburg. This section will outline the design requirements.

7.1 Other Reference Documents

All roads and transportation systems are to be designed and constructed in accordance with the latest version of this manual as well as other industry standards and best practices, including but not limited:

- Oxford County Official Plan
- Town of Tillsonburg Standard Drawings
- Ontario Provincial Standard Specifications (OPSS) and Ontario Provincial Standard Drawings (OPSD) prepared by the Ministry of Transportation (MTO)
- Geometric Design Guide for Canadian Roads prepared by the Transportation Association of Canada (TAC)
- Ontario Traffic Manual (OTM) prepared by the Ministry of Transportation (MTO)
- Roadway Lighting ANSI/IES RP-8 prepared by the Illuminating Engineering Society of North America (IESNA), latest edition
- O. Reg. 366/18: Minimum Maintenance Standards for Municipal Highways

7.2 Industry Standards and Specifications

All roads and transportation systems are to comply with the latest version of all applicable industry standards and specifications for quality management and quality control, including but not limited to the following:

- Electrical Safety Authority (ESA)
- Canadian Standards Association (CSA)
- American Society for Testing and Materials (ASTM)

7.3 Other Applicable Acts and Legislations

This manual does not supersede, nor replace any legislation governing the design and construction of roads and transportation systems. When carrying out design and construction of

Town linear projects, the Proponent is to be fully familiar with the latest version of the following legislative requirements:

- Ontario Highway Traffic Act
- Municipal Act
- Environmental Assessment Act
- Environmental Protection Act
- Accessibility for Ontarians with Disability Act (AODA)

7.4 Road Classifications

All urban roadways shall be classified according to the traffic volume expected and the intended use of the roadway. The proposed classification of all streets in the development shall be confirmed with the Town prior to commencement of design.

All roads within the urban boundary shall be designed and constructed to Town standards with full municipal services.

Table 1 is presented as a summary of the three major road classifications within the Town. However final classification will ultimately be determined by and at the sole discretion of the Town.

Table 1. Street Classifications - Residential

	Local	Collector	Arterial
Surfaced Width (m)	8.0	10.0	14.0
Right of Way (R.O.W) (m)	20.0	22.0	26.0
Number of Through Lanes per Direction	1	1	2
Traffic Volume Range (AADT)	Less than 2,000	2,000 to 4,000	Greater than 4,000
Posted Speed Range (km/h)	40-50	50	50 - 60 ¹
Minimum Design Speed (km/h)	60	70	80
Utility Location	As per the Town of Tillsonburg Typical Cross Sections		

1. *Proponent to confirm with the Town and County prior to Design.*
2. *School / community safety zone 40*
3. **CONFIRM SPEED**

7.5 Roadway Cross-sections

Refer to the typical cross-sections illustrated in Appendix “A” Town of Tillsonburg Standard Drawings, within these guidelines for requirements on above and below grade infrastructure for local, collector, and arterial roads.

Typical cross-sections are included in Appendix “A” of manual for the following:

- Local Roads
- Collector Roads
- Arterial Roads

The cross-sections are provided for guidance purposes during design and construction.

Deviations may be necessary and will be reviewed and accepted by the Town on a case-by-case basis.

The Proponent shall provide justification for the change for review at the full discretion of the Town. 18.0m R.O.W can be used in reconstructions pending Town approval. 18.0m R.O.W within new subdivisions are not permitted unless received Town approval such as “window lanes”.

7.5.1 Bike Lanes

Bike lanes shall be incorporated into typical road cross-sections at the request of the Town. Bike Lanes shall be a minimum of 1.5m in width and shall clearly be delineated with pavement markings from the vehicle travel lane on collector and arterial roads.

7.6 Geometric Design Elements

Geometric design for horizontal and vertical road alignment must meet the following requirements or the TAC Geometric Design Guide for Canadian Roads Part 1 and Part 2, whichever is more conservative.

All points of grade change in excess of 1.0% shall be designed with vertical curves as outlined in the TAC Guide and shall list the vertical curve properties on the plan and profile drawings.

Table 2. Geometric Design Elements

Geometric Detail	Local	Collector	Arterial
Maximum Longitudinal Road Grade (%)	8.0	8.0	6.0
Minimum Longitudinal Road Grade (%)	0.5	0.5	0.5
Minimum Crossfall (%)	2.0	2.0	2.0

Geometric Detail	Local	Collector	Arterial
Sidewalk Separation from Back of Curb (m)	2.2	2.2	2.2
Maximum Sub Base Grade (%)	3.0	3.0	3.0
Maximum Grade Major Approach at Intersection (%)	2.0	2.0	3.0
Grade for Minor Approach at Intersections (%)	Match cross fall of major approach		
Minimum Curb Grade (%)	0.5	0.5	0.5
Vertical Curve Minimum Sight Stopping Distance (m)	85.0	85.0	85.0 – 140.0
Maximum Superelevation (%)	2.0	2.0	2.0

7.7 Intersections

All standards pertaining to the design of intersections are as outlined in Table 2 and shall be in accordance with TAC Geometric Design Guide for Canadian Roads, latest edition.

Should there be an island within the intersection, the Proponent must have a suitable separation and radius to allow for a Tandem Axle Plough complete with wing with a 0.5m buffer.

At a minimum, curb return radii measured from edge of pavement and the daylighting (sight triangle) requirements from property line shall meet the following as outlined in Table 3.

Table 3. Curb Return Radii

Street to Street	Minimum Curb Return Radii	Daylighting
Local to Local	7.5m R	3m x 3m
Local to Collector	9.0m R	5m x 7m
Local to Arterial	9.0m R	5m x 10m
Collector to Collector	12.0m R	7m x 7m
Collector to Arterial	12.0m R	7m x 10m
Arterial to Arterial	15.0m R	10m x 10m
Industrial to any other street	18.0m R	12m x 12m

7.8 Cul-de-Sacs

Where necessary and approved by the Town, temporary and permanent cul-de-sacs are to be implemented in accordance with this manual.

The minimum radii of the cul-de-sac as measured from the edge of pavement shall be 15m. The minimum road allowance radii of the cul-de-sac is to be 20m as per the Town standard drawings.

Minimum gutter grades of 0.8% are to be maintained along the flow line of all gutters around the cul-de-sacs, the design road grade on the cul-de-sac and at the beginning of the bulb area where catchbasins are to be located.

The details shall show gutter, crown and other grades sufficient to determine that the road will properly drain.

7.9 Temporary Roads

Temporary roads shall be constructed with smooth transitions to paved structures. Pavement design for temporary roads are to be confirmed by a qualified Geotechnical Engineer and have a minimum of 450mm Granular 'B' and 150mm Granular 'A'.

7.10 Emergency Access

Emergency access shall be designed in consultation with emergency services and the Town. The use of knock over bollards and gates shall be evaluated on a case by case basis.

7.11 Pavement Design

7.11.1 General Requirements

Minimum thickness of asphalt and granular materials are provided in Table 4. These designs are considered to be minimums and final thickness are to be recommended and confirmed by a qualified Geotechnical Engineer.

All designs are to be submitted to the Town for approval and shall comply with the current OPSS standards.

Table 4. Minimum Pavement Design Requirements

Road Classification	Surface Course HL3 (mm)	Base Course HL8 (mm)	Granular 'A' (mm)	Granular 'B' (mm)	Total (mm)
Local	40	50	150	300	540
Collector	40	60	150	375	625
Arterial	50	60	150	450	710

Road Classification	Surface Course HL3 (mm)	Base Course HL8 (mm)	Granular 'A' (mm)	Granular 'B' (mm)	Total (mm)
Industrial	50 (HL4)	60	150	450	710

7.11.2 Alternative Materials

The Town may consider alternative materials on a case-by-case basis, such as reclaimed concrete and asphalt for typical granular applications such as:

- Engineered fill
- Pavement shoulders
- Construction access roads, bike paths and trails,

A qualified Geotechnical Engineer shall outline the suitability and location of reuse of reclaimed materials and shall be submitted for approval to the Town. The materials shall be in accordance with OPSS.

7.12 Concrete Curb

Curb and gutters shall be in accordance with OPSS 353 and OPSD 600.10, 600.04 and 600.09.

The minimum curb and gutter grade will be 0.5% unless it is located in cul-de-sacs where it will be 0.8%.

For all retrofit projects, concrete curb will be curb and gutter as per the Town's typical cross section for the road type in accordance with the applicable OPSD, or as otherwise approved by the Town.

7.13 Subdrains

Subdrains are to be in accordance with the applicable OPSS. Subdrains are to be installed a minimum of 3.0m from each catchbasin structure. Additional Subdrains may be required on a case-by-case basis as specified by a qualified Geotechnical Engineer and or the Town or where the majority of longitudinal grades are less than 1% in fine clay or silt conditions. Subdrains are to include the connection of an outlet to a drainage structure.

Subdrains shall be perforated high density polyethylene pipe complete with geotextile sock with a minimum diameter of 150mm and a minimum slope of 0.5% installed continuously below the curb and gutter complete with clear stone bedding wrapped in filter fabric, unless soil conditions warrant otherwise as recommended from a Geotechnical Engineer. Subdrains shall be installed in accordance with OPSD 216.021.

7.14 Driveways

7.14.1 General Requirements

Driveways and approaches/curb depressions are to be designed in accordance with OPSS, OPSD, Town of Tillsonburg Zoning By-law.

Minimum design grade for all driveways are 2% and maximum grade are 8.0%. The specified driveway grade shall be directed away from the lot towards the roadway. The use of reverse fall driveways is not permitted.

Existing driveway to property and driveway approaches are to be replaced with like materials if impacted by construction activities.

All new driveways and approaches within the Town's R.O.W. shall be submitted to the Town for review and approval prior to construction. The details shall include the location, width, slopes and grades.

Existing curb returns at driveways will be reinstated on a case-by-case basis as approved by the Town.

A minimum driveway separation distance shall be determined based on TAC standards, Town of Tillsonburg Zoning By-law (No.3295 as amended), and in accordance with OPSS.

7.14.2 Driveway Materials

Table 5 outlines material requirements for asphalt and concrete driveways. All driveways are to be in accordance with OPSS and this manual.

Driveway and driveway approaches shall match existing conditions wherever possible and applicable. Any deviation is to be reviewed and approved by the Town.

Table 5. Driveway Requirements

Land Use	Asphalt	Concrete
Single Family Residential	50mm of HL3 surface course 200mm of Granular 'A'	125mm Concrete 150mm Granular 'A'
Apartments, Commercial and Light Industrial Properties	40mm of HL3 surface course 50mm of HL4 base course 300mm of Granular 'A'	150mm Concrete 150mm Granular 'A'
Heavy Industrial Properties	50mm of HL4 surface course 60mm of HL8 base course 300mm of Granular 'A'	200mm Concrete 300mm Granular 'A'

7.15 Curb Depression

Curb depressions are required at all pedestrian road crossings and provide the smooth integration of vehicles to and from roadways at driveways. These are to be designed in accordance with Town of Tillsonburg Zoning By-law and the Accessibility for Ontarians with Disability Act (AODA).

7.16 Sidewalks

The location and extent of sidewalks shall be reviewed and approved by the Town and shall conform to typical Right of Way cross-sections as per the Town’s Standard Drawings wherever possible.

Sidewalk locations should first be located in areas to promote continuity of routes and provide direct access to major pedestrian destinations. It is the preference of the Town for the sidewalk to be located on the north and east side of the roadway in cases of only one sidewalk.

The Proponent shall take all precautions to minimize impacts to existing and propose driveways.

Reconstruction projects must have the sidewalk replaced or repaired if an existing sidewalk is in place. In the absence of an existing sidewalk, a new sidewalk is to be considered, at the discretion of the Town. Sidewalks shall be designed in accordance with Accessibility for Ontarians with Disabilities Act (AODA) requirements. Best attempts to eliminate depressing the sidewalk at driveways shall be taken,

Should sections of sidewalk be removed as part of development works, the minimum number of panels to be removed and replaced shall be three (3) on connecting streets to provide a smooth transition. Table 6 outlines typical concrete sidewalk design parameters.

Table 6. Concrete Sidewalk Parameters

Parameter	Requirement
Sidewalk Thickness	Residential – 125mm Street Crossings – 200mm Industrial/commercial entrances – 150mm
Sidewalk Width	1.5m (Local roads), 1.8m adjacent to curb as per OPSD 310.020
Sidewalk Grade *	0.5% to 8%
Sidewalk Crossfall	2% to 4%
Distance from Curb	Minimum 2.2m between back of curb and sidewalk

* Steeper grades shall be reviewed and approved by the Town based on site conditions.

7.16.1 Tactile Surface Warning Plates

As a minimum, tactile surface warning plates shall be integrated into sidewalks at curb ramps and depressed curb areas to assist pedestrians who are visually impaired. They shall be designed in

accordance with OPSD 0310 series, Accessibility for Ontarians with Disabilities Act (AODA) requirements and the Town of Tillsonburg Accessibility Plan, latest versions and as approved by the Town.

7.17 Location of Utilities

The location of all utilities within the road allowance are to be in accordance with the Typical Cross-section as per the Standard Drawings in this manual and Section 9 - Utilities of this document.

7.18 Parking

Parking is to be in accordance with the details in Town of Tillsonburg Traffic and Parking By-law.

7.18.1 Accessibility Parking

Where accessibility parking is warranted, the design and implementation shall be in accordance with the Accessibility for Ontarians with Disabilities Act (AODA) requirements and Town of Tillsonburg Traffic OTM Book 11, and Parking By-law, amended.

7.19 Topsoil, Seed and Sod

Topsoil shall be of the best quality fertile, loose, loamy material screened to be free from stones and weeds, to be placed and graded in the locations and to a minimum depth of 150mm as directed by the Town. Topsoil must not contain any chemical contamination or material detrimental to plant growth.

Bags are to bear the seed supplier's label clearly indicating species' content, grade and mass as well as the recommended seeding rate for the establishment of new lawn areas.

Sod shall be Commercial Grade Kentucky Bluegrass Nursery Sod according to the Specifications, Classifications and Use of Turfgrass Sod for Nursery Sod Growers Association of Ontario.

Sod shall be seeded and established in nursery sod fields as a turfgrass sod. There shall be no more than 5 broadleaf weeds per 40 square metres of sod and up to 20% non-specified grass. Sod shall be of sufficient density that no surface soil is visible.

Fertilizer shall be supplied in bags bearing the manufacturer's label indicating mass and analysis. All fertilizer shall be in granular form: dry, free flowing, free from lumps and with a composition of 8-32-16 (P-K-N) as per OPSS 803.

7.20 Fences and Walls

7.20.1 Fences

Fencing shall be implemented within the ROW as required by the Town. Fencing is not required where noise barrier walls are to be installed. Fencing within the ROW shall be a

minimum of 1.52m (5ft) and be non-climbable as required in the Town's Pool Enclosure By-Law.

If designed of chain link:

- (a) have a diagonal mesh length of not greater than 38mm and shall consist of 12-gauge galvanized steel wire; and
- (b) no rails, bracing or exposed attachments on the exterior that could facilitate or permit climbing from the exterior; and top and bottom rails are firmly fastened to upright posts, which rails consist of galvanized steel pipe at least 32 millimetres (1.25 inches) thick, provided that a continuous galvanized steel tension rod at least 5 millimetres (0.2 inches) thick may be substituted for the bottom rail. All private fencing shall be located entirely on private property and shall conform with standards outlined in the Town of Tillsonburg Fence By-Law and/or Pool Enclosure By-Law. Private gates shall not be allowed on fencing along the R.O.W.

7.20.2 Noise Attenuation Walls

The acoustical design and structure of all required noise attenuation walls shall be approved by the Town. A noise attenuation wall abutting Town property shall be located a minimum of 0.3m from the property line in the R.O.W.

All private noise attenuation walls shall be located entirely on private property and shall be designed by a Professional Engineer.

7.20.3 Subdivision Entrance Structures

The Town will not accept any subdivision gate or decorative entrance structures to be located on the R.O.W. If these entrances are required, the Proponent shall locate the structure entirely on private property. The Town will not be responsible for the future maintenance or repairs of any such subdivision entrance structures.



Section 8



Table of Contents

8	STREETLIGHTING	1
8.1	General Requirements.....	1
8.2	Design Criteria.....	1
8.2.1	Within Public ROW.....	1
8.2.2	Site Plans.....	4
8.2.3	Lighting Configurations and Pole Offsets.....	5
8.2.4	Installation.....	5
8.2.5	Materials.....	6

List of Tables

Table 1. Maintained Luminance for Mid-Block Street Sections (Non-Intersection Areas)

Table 2: Maintained Luminance for Street Corridors near Intersections, Curvilinear Sections and Pedestrian Walkways/Bikeways Table 3. Tree Protection Zones

Table 3. Streetlighting Material List

8 STREETLIGHTING

8.1 General Requirements

All roadways are to be lit, unless written approval is received from the Town. Streetlights shall be provided throughout all developments and may be required on roadways bordering developments if deemed necessary by the Town.

A qualified engineering consultant shall prepare the streetlight design, including photometric layouts using an approved computer lighting program such as AGI 32, AutoLux, or equivalent.

All drawings must be sealed by a registered electrical Professional Engineer, licensed to practice in the Province of Ontario. Any attachments to hydro poles must have Hydro Authority approval and comply with Regulation 22/04 (or the latest revision thereof). All roadway lighting design and construction is subject to Electrical Safety Authority (ESA) inspection and approval.

The Transportation Association of Canada (TAC) “Guide for Design of Roadway Lighting”, Volumes 1 and 2 provide comprehensive design guidelines and may be used for lighting devices for roadways and associated facilities.

8.2 Design Criteria

8.2.1 Within Public ROW

Lighting design criteria for roadways, sidewalks, pedestrian walkways, and bikeways on public right-of-ways within the Town of Tillsonburg shall be based on the “American National Standard Practice for Roadway Lighting”, ANSI/IESNA RP-8-14, or the latest revision thereof.

The lighting system shall provide the average maintained light levels and meet the recommended uniformities and veiling luminance ratios as indicated in Table 4 and 5.

“Luminance” criteria may be used for determining light levels on straight and level roads that have a minimum length of ten (10) luminaire mounting heights.

“Illuminance” criteria to be used for intersections, curvilinear road sections, pedestrian walkways, and bikeways.

The design criteria requirements for luminance, illuminance, and pedestrian conflict area classifications in Tables 1 and 2 are derived from ANSI/IES RP-8-14.

The criteria listed in Table 2, for intersections, is to be applied to cover the thirty-two (32) conflict points identified in ANSI/IES RP-8-14 (se. 5.1.2). The criteria listed in Table 4 would apply outside of this.

Local roads within new subdivisions will use black coated Standard Roadway Luminaires: LED – Decorative light poles and fixtures unless expansion of existing subdivision and transition from existing pole and fixture colour and type cannot occur; to be approved by Town staff.

Table 1. Maintained Luminance for Mid-Block Street Sections (Non-Intersection Areas)

Road Classification	Minimum Average Maintained Luminance L_{avg} (cd/m ²)	Maximum Uniformity Ratio L_{max} to L_{min}	Maximum Luminance Ratio L_{avg} to L_{min}	Maximum Veiling Luminance Ratio L_v to L_{avg}	Pedestrian Conflict Area Classification
Arterial/Major Roads	0.6	6.0 to 1	3.5 to 1	0.3 to 1	Low
Arterial/Major Roads	0.9	5.0 to 1	3.0 to 1	0.3 to 1	Medium
Collector Roads (Minor)	0.4	8.0 to 1	4.0 to 1	0.4 to 1	Low
Collector Roads (Major)	0.6	6.0 to 1	3.5 to 1	0.4 to 1	Medium
Local Roads (Rural)	0.3	10.0 to 1	6.0 to 1	0.4 to 1	Low
Local Roads	0.5	10.0 to 1	6.0 to 1	0.4 to 1	Medium

Table 2. Maintained Luminance for Street Corridors near Intersections, Curvilinear Sections and Pedestrian Walkways/Bikeways

Maintained Illuminations for Roadways near Intersections and Curvilinear Sections		
Road and Pedestrian Conflict Area Classification	Minimum Average Maintained Illuminance (Horizontal Only) (R2 & R3 Pavements) E_{avg} (lux)	Maximum Illuminance Uniformity Ratio E_{avg} to E_{min}
Arterial/Major Roads - Low	9	3.0 to 1
Arterial/Major Roads - Medium	13	3.0 to 1
Collector Roads (Minor) - Low	6	4.0 to 1
Collector Roads (Major) - Medium	9	4.0 to 1
Local Roads (Rural) - Low	4	6.0 to 1
Local Roads (Urban/Industrial) - Medium	7	6.0 to 1

Maintained Illuminations for Pedestrian Walkways/Bikeways		
Road and Pedestrian Conflict Area Classification	Minimum Average Maintained Illuminance (Horizontal Only) (R2 & R3 Pavements) E_{avg} (lux)	Maximum Illuminance Uniformity Ratio E_{avg} to E_{min}
Rural and Semi - Rural Areas	2	10.0 to 1
Pedestrian Areas – Low (2 or fewer dwelling units per acre or 5 units per ha)	3	6.0 to 1
Pedestrian Areas – Medium (2.1 to 6 dwelling units per acre or 5.1 to 15 units per ha)	5	4.0 to 1

Intersections shall have an illumination level equal to the sum of the recommended average illumination levels for each of the intersecting roadways. If it is not practical to achieve this level due to geometric constraints, then a minimum level of 50% higher than the recommended level for the main roadway may be acceptable, subject to the Town’s approval. Alternatively, Town may request to follow Table 8 in ANSI/IES RP-8-14, or any update of this standard.

For illumination of crosswalks (mid-block or at intersections) refer to Section 5.3 of ANSI/IES RP-8-14.

Light levels shall be increased by 50% through school areas, libraries, recreation centres, medical centres, railway crossings, bridges and any other location where increased conflict is possible. The street lights shall typically be serviced with underground wiring in ducts between poles. The luminaires shall be alternated between circuits to maintain 50% illumination upon loss of one circuit feeder.

Light source for roadway lighting shall be long life (minimum 100,000 hours).

Power supply shall be coordinated and arranged with the Supply Authority from the nearest feasible location. Power supply shall be unmetered and the street lights shall operate at 120 volts 60 Hz AC. Maximum voltage drop at the end of the lighting circuit shall not exceed 5% of the supply voltage.

The design drawings shall show all surface features, all street light pole complete with ID#, all power pedestals complete with ID#, the individual conduits from the power pedestal to the light-emitting diode (LED) lights, the conduit from street light pole to street light pole, all utility road crossings with dimensions from the road crossing to either a side lot line or a street light pole, and dimensions from the street light pole to the lot lines where the street light pole is not opposite a side lot line. The LED street light ID# shall include the type of LED lighting fixture, the circuit number, and the power pedestal number to which it is connected. The Legend shall include duct sizes and an explanation of the street light symbol/ID#’s.

On the single line drawing, there should be an electrical schematic for each power pedestal showing the transformer (complete with Town ID#) that supplies power to the power pedestal, the power pedestal cabinet contents (service breakers, service panel, grounding rods, etc.), each circuit and all of the LED street lights (complete with ID#) connected to that circuit with conductor lengths from the pedestal to the first light and from light to light, and all electrical components inside the LED street light fixtures. It should be noted that the maximum conductor length is 100 m.

Lighting calculations shall be prepared for all outdoor site lighting and forwarded to the Municipality for approval.

All luminaires are to be provided with ANSI C136.41 compliant dimming photocontrol allowing at least three different settings for dimming levels and start times.

Refer to Table 3 for a list of materials and specifications.

Streetlight designer should contact Town and confirm full set of criteria before the start of design.

8.2.2 Site Plans

Lighting should be controlled by automatic switching devices such as timers or photocells.

Parking Lots

Parking lot illumination has to address good visibility for drivers and pedestrians, provide good colour rendition for security identification, and leave sufficient impact for customer attraction.

The recommended light levels for high activity community shopping developments are:

- Average maintained illuminance level 2.0 fc (20 lux) minimum. This could be increased up to 5.0 fc (50 lux), as is common practice for current commercial developments
- Uniformity, average to minimum 4:1

The minimum recommended light levels for parking lots are:

- Minimum horizontal illuminance level 0.2 fc (2 lux)
- Uniformity ratio, maximum to minimum 20:1

Roadways

The recommended light levels for the site roadway zones are:

- Average maintained illuminance level 0.9 fc (9.0 lux)
- Uniformity, average to minimum 6:1

Pedestrian Walkways

The recommended light levels for pedestrian walkways up to and surrounding any commercial buildings are:

- Average maintained illuminance level for medium activity areas 2.0 fc (20 lux) and high activity areas 4.0 fc (40 lux)
- Uniformity, average to minimum 4:1

Site Restriction

The recommended light levels projected onto a residential property (spill light) shall not exceed 0.1 vertical foot candles, measured line-of-site at the property line.

Pylon Signs

Externally illuminated pylon signs shall have the light source aimed downward towards the sign.

8.2.3 Lighting Configurations and Pole Offsets

All streets are to employ a staggered streetlight configuration with pole offsets from EP as per TAC criteria or on shoulder rounding.

In rural areas where TAC pole offsets outside the clear zone are not possible, frangible breakaway bases may be used. Frangible bases are not permitted at intersections and areas where pedestrians are expected.

Pole offsets that are identified on the Town's Typical Road Cross Sections take precedence.

Lights at signalized intersections should be combined with joint-use traffic signal poles wherever possible.

On curved roadways, the light poles should be positioned on the inside of curves, if possible. Alternatively, light poles may be placed on the outside of curves, but shall be kept out of the vehicle overrun area (the extension of the tangent in the direction of vehicle travel).

Street lights and power pedestals should be located on the extension side lot lines where possible.

8.2.4 Installation

The installation of the street lighting system shall be in compliance with ESA, CSA, the Hydro Supply Authority requirements, the Town's standards and specifications, as well as the manufacturer's installation instructions.

Ducts

Ducts shall be solvent welded together in trenches with minimum cover of 750 mm. Ducts shall be surrounded by 80 mm of brick sand and warning tape to cover width of trench.

Road crossings to be carried out by directional bore method using thickwall PVC duct.

Where open-cut road crossings are necessary, ducts shall be concrete encased.

Installation as per OPSD 2100.06, 2103.02 and OPSS 603.

Cables

Cables to be continuous without splices and shall be installed after trenches are back-filled.

Installation Specifications as per OPSS 604.

Fuses

Fuses in pole handholes as per OPSD 2255.020 and OPSS 617.

Grounding

Ground rods to be installed at power service disconnect (minimum 2 rods), at every fifth (5th) lighting pole, and at the last lighting pole in each circuit.

Installation Specifications as per OPSS 609.

Poles

Installation Specifications as per OPSS 615.

Brackets and Luminaires

Installation Specifications as per OPSS 617.

Power Service Disconnect

Installation Specifications as per OPSS 614.

Dimming control

Specifications as per ANSI C136.41. DIM-4 adjustable control.

8.2.5 Materials

All materials used for street lighting must be CSA approved. Refer to Table 3 for a list of Materials and Specifications.

Table 3. Streetlighting Material List

Material	Standards	Features	Manufacturer	Catalogue No.
1.0 Lighting				
Electrical Handholes	CSA	Precast concrete type complete with cover, 460mm Dia., as per OPSD 2112.02.		
Ducts	CSA C22.2, No.211.1 CSA C22.2, No.211.2 CSA Standard B137.1, Series 75 or ENT CSA C22.2, No.227.1	In boulevard, rigid PVC DB2 duct, 53mm Dia. Below roadways, rigid PVC Thickwall duct, 53mm Dia. Flexible duct (Polypipe) to be used for protection of cables entering the wiring aperture in the concrete poles.		
Cables	CSA C22.2 No.38	Power supply cables shall be 3-#2 AWG copper RWU90 (including ground wire), with cross- linked polyethylene insulation rated 600 volt. Street light cables shall be 1-2C#6AWG copper and #10 AWG copper GND, 60°C, NMWU; or 2-#6 AWG copper RW90 and #8AWG copper GND RW90 Riser wires from pole handhole to luminaire shall be #12 AWG stranded copper type RWU90 insulation. Insulation colour for line conductors for 1-phase, 3-wire 240/120V system shall be "Red" and "Black" and for 1 phase, 2-wire 120V system shall be "Red". Insulation colour of all neutral conductors shall be "White". Cable connectors in pole handholes shall be compression connectors with insulating covers.		
Fuses		Fuse holders in pole handholes shall be in-line break-away type rated 600V complete with 10 amp KTK fuse.		
Grounding	CSA C22.2 No.41	Ground rods shall be solid steel, 19mm Dia., 3.0m long, copper clad for full length.		

Material	Standards	Features	Manufacturer	Catalogue No.
2.0 Poles				
Standard Roadway Lighting Poles	CSA A14-M1979	<p>Direct Buried, Class “B” spun concrete, tapered round with natural concrete smooth mold finish, complete with handhole cover plate, nameplate and ground lug.</p> <p>Arterial Roads – 12.2m (40ft) Collector Roads – 10.7m (35ft) or 12.2m Local Roads – 7.5m (25ft) or 10.7m</p> <p>Base mounted galvanized octagonal steel poles as per OPSD-2415.010.</p> <p>Arterial Roads – 10.5m Collector Roads – 9.0m/10.5m Local Roads – 7.5m/9.0m</p>	StressCrete Sky Cast U.S.I.	
Poles for Walkways/Bikeways		<p>Base mounted contemporary pole with high tensile carbon steel shaft round (76mm) welded to top and bottom of anchor plate.</p> <p>Pole to be black semi-gloss powder coat finish complete with base cover assembled with stainless steel hardware.</p> <p>Photobutton light control recessed near top of pole.</p>		
Poles for Commercial Sites		<p>Poles shall be metal type square or round to suit the luminaire style and shall be base mounted. Poles shall have durable powder coat finish, colour to match the luminaire.</p> <p>Poles in parking areas shall be restricted to 30 ft. (9.1m) in height. Poles may be reduced in height down to 12 ft. (3.65m) level for pedestrian pathway applications.</p> <p>Wherever feasible, poles shall be located off the edge of pavement, behind barrier curbs (islands).</p> <p>Concrete bases in parking areas shall be protected by bollards or shall be raised to minimum 900mm above grade and be 760mm diameter.</p>		
3.0 Brackets				
Standard Roadway Lighting Brackets		<p>Tapered elliptical aluminium brackets as per OPSD 2420.01. The length of the bracket depends on offset from pavement and pole height.</p> <p>Arterial Roads – 2.4m (10ft) preferred, 3.0m maximum Collector Roads – 1.8m (8ft) preferred. Local Roads – 1.2m (6ft) preferred.</p>		
Walkways/Bikeways Brackets		<p>Single or double brackets with bend aluminium tubing with decorative aluminium rod, welded assembly and cast aluminium adaptor.</p>		

Material	Standards	Features	Manufacturer	Catalogue No.
4.0 Luminaires				
Standard Roadway Luminaires: High Pressure Sodium				
NOTE – HPS fixtures were allowed in the past. Currently all luminaires are to be LED type. This section is kept for general information only. Designer to consult the Town at the project start-up to confirm all design parameters.				
Arterial/Industrial Roads		<p>“Cobra Head” style, type II or III distribution pattern, medium cutoff, internally shielded with flat tempered glass lens and photocontrol receptacle.</p> <p>Lamp wattage to be long life 200W to 400W high pressure sodium.</p> <p>Luminaire housing to be die-cast aluminum with latch and standard grey polyester powder coat finish.</p> <p>Permanent type marking to be applied on underside of the luminaire housing for lamp wattage identification, (Yellow for HPS).</p> <p>Ballast to be C.W.I., 120 volt, 60Hz.</p>	<p>Cooper Lighting (OVF)</p> <p>AEL (series 315)</p> <p>GE (M-400A)</p>	
Collector Roads		<p>“Cobra Head” style, type II or III distribution pattern, medium cutoff, internally shielded with flat tempered glass lens and photocontrol receptacle.</p> <p>Lamp wattage to be long life 70W to 150W high pressure sodium.</p> <p>Luminaire housing to be die-cast aluminum, with latch and standard grey polyester powder coat finish.</p> <p>Permanent type marking to be applied on underside of the luminaire housing for lamp wattage identification, (Yellow for HPS).</p> <p>Ballast to be C.W.I., 120 volt, 60Hz.</p>	<p>Cooper Lighting (OVH)</p> <p>AEL (Series 315)</p> <p>GE (M-250R2)</p>	
Photo-controller		<p>Model TRS-1</p> <p>Photocontroller to have minimum surge protection of 40,000 amps and a minimum load rating of 1,000W/1,800 VA.</p> <p>Must have operating strength of 5,000 volts, and the photocell must be silicon sensor in glass and metal hermetic enclosure.</p> <p>Photocells shall be rated for a minimum of 100,000 operational hours.</p>	<p>FP Outdoor Lighting Controls/Sunrise Technologies</p>	

Material	Standards	Features	Manufacturer	Catalogue No.
Standard Roadway Luminaires				
Standard Roadway Luminaires: LED – Cobra Head		<p>Luminaire – Cobra Head style, type 2 or 3 distribution pattern, rugged die cast aluminum housing with surge and brown-out protection, LED drivers and electronic transfer switch. Temperature control by robust heat sink ensuring a minimum of 80,000 hours L70 at 40C operating ambient.</p> <p>Operating range from – 40 to + 50C with light engines meeting the dust and moisture rating of IP-66.</p> <p>Luminaire design to meet CSAC22.2 number 250 for 40C, wet location and to be ROHS compliant. Maximum total harmonic distortion to conform to ANSI C82.77: 2002.</p> <p>Solid state 120 volt 60 Hz electronic drivers with extended life to 100,000 hours minimum.</p> <p>LED colour temperature 4000 K nominal.</p> <p>All luminaires to be provided with a Dimming Module.</p> <p>5 year limited warranty on LED light engine, LED drivers and all non-electrical components.</p>	General Electric	<p>ERL1005B340A GRAYL</p> <p>ERL1007B340A GRAYL</p> <p>ERL1008B340A GRAYL</p> <p>ERL1010B340A GRAYL</p> <p>ERL1014B340A GRAYL</p>
Standard Roadway Luminaires: LED – Decorative		<p>Luminaire – Decorative lantern style, available in numerous distribution patterns to meet project specific requirements, rugged die cast aluminum housing with surge and brown-out protection, LED drivers.</p> <p>Operating range from – 40 to +40C, LED luminaire to meet IP65 rating. Luminaire design to meet CSA-C22.2 number 250 for 40C, wet location and to be ROHS compliant. Maximum total harmonic distortion to conform to ANSI C82.77: 2002.</p> <p>Solid state 120 volt 60 Hz electronic drivers with extended life to 100,000 hours minimum. Temperature control by robust heat sink ensuring a minimum of 100,000 hours L70 at 40C operating ambient</p> <p>LED colour temperature 4000 K nominal.</p> <p>All luminaires to be provided with a Dimming Module.</p> <p>Minimum 7 year limited warranty (10 year preferred) on LED light engine, LED drivers and all non-electrical components.</p>	<p>General Electric</p> <p>Phillips</p>	<p>K601D-S-P4NL-III-60(SSL)7030-120-4K-F4</p> <p>K601D-T-P4NL-III-40(SSL)7030-120-4K-F4</p> <p>K118R-B3AR-III-40(SSL)1036-120-K14-4K-F1</p> <p>MPTR-55W48LED4K-T-LE2-UNIV-RCD-NP</p>
Park Walkway/Bike way Luminaires		50W pulse start metal handle.	<p>General Electric</p> <p>Eaton</p>	<p>ERL1H05B340A GRAYL</p> <p>PRVA15DUNVT 2SABZ</p>

Material	Standards	Features	Manufacturer	Catalogue No.
Commercial Site Luminaires: Metal halide		<p>In general shall be of the “Architectural Site Lighting” style, contributing a cohesive look to the overall site lighting system.</p> <p>The architectural outdoor luminaires may be shoe-box or round type with good optics and full cut-off with optional house side shielding.</p> <p>Luminaires at lower mounting heights shall have a vandal proof lens. The luminaires shall be post top arm mounted suitable for 1A to 4C configurations and also be suitable for optional wall mount applications.</p> <p>Luminaire housings shall be diecast type with durable powder coat finish colour to match site architectural features.</p> <p>Lamp wattage for parking lot and site roadway lighting shall be in the 150 to 400 watt range, subject to application. Lamp wattage for pedestrian scale pathway and building zone lighting may be reduced to 70 watt metal halide.</p>		
5.0 Power Supply Management				
Pole Mounted Disconnects		<p>Pole mounted power supply disconnects shall be outdoor weatherproof type 240/120 V rated 100 amps with 60 amp 2 pole main breaker suitable for service entrance.</p>		
Pedestal Mounted Disconnects		<p>Pedestal mounted power supply disconnect shall be outdoor heavy gauge galvanized steel with lockable removable front cover complete with precast concrete base.</p> <p>Colour to be equipment green with powder coat finish.</p> <p>Interior power supply disconnect shall be 240/120 V rated 100 amps with 60 amp 2 pole main breaker suitable for service entrance. Branch breakers to be 30 amps 1 pole 120V.</p>	Pedestal Solutions Inc.	



Section 9

Table of Contents

9	UTILITIES	1
9.1	General Requirements	1
9.2	Other Reference Documents.....	1
9.3	Industry Standards and Specifications.....	1
9.4	Town of Tillsonburg Permits and Approvals.....	2
9.5	Long Point Region Conservation Authority Permits and Approvals	2
9.6	Composite Utility Plans	2
9.7	Minimum Cover.....	2
9.8	Alignment.....	3
9.9	Utility Clearances	3
9.10	Separation from Trees	4
9.11	Underground Structures.....	5
9.11.1	Location of Structures.....	5
9.12	Surface Structures	5
9.12.1	Loading Criteria.....	5
9.12.2	Placement Criteria.....	5
9.12.3	Surface Criteria	6
9.13	Poles and Anchors.....	6
9.13.1	Location of Poles.....	6
9.13.2	Down Guy and Anchor	7

List of Tables

Table 1. Minimum Clearances from Utilities

Table 2. Minimum Clearances for Utility Vaults and Structures

9 UTILITIES

9.1 General Requirements

This manual has been prepared to provide the Town, consulting engineers, contractors, developers, utility providers and the general public with a common reference to ensure the consistent application of utility design in the Town.

The information provided is not intended to hinder innovation and is rooted on meeting performance requirements over the lifecycle of the infrastructure. The Proponent shall provide justification for any deviation from the criteria and requirements set out in this manual, and approval will be granted at the Town's discretion.

9.2 Other Reference Documents

All utilities shall be designed and constructed in accordance with the latest versions of this manual as well as other industry standards and best practices, including but not limited to:

- Ontario Regional Common Ground Alliance (ORCGA)
- Ontario Provincial Standard Specifications (OPSS) and Ontario Provincial Standard Drawings (OPSD) prepared by the Ministry of Transportation (MTO)
- Standard Guidelines for the Collection and Depiction of Existing Subsurface Utility Data (ASCE 38-02) prepared by ASCE

9.3 Industry Standards and Specifications

All utilities materials and components shall comply with the most recent version of all applicable current industry standards and specifications for quality management and quality control, including but not limited to the following:

- Electrical Safety Authority (ESA)
- Canadian Standards Association (CSA)
- Other Applicable Acts and Legislations

This manual does not supersede, nor replace any legislation governing the design and construction of utility infrastructure. The Proponent shall be fully familiar with the latest version of these legislative requirements when carrying out design and construction of linear projects, such as:

- Canadian Electrical Code
- Ontario Electrical Safety Code
- Ontario Underground Infrastructure Notification Systems Act (ON1Call)

- Technical Standards & Safety Authority (TSSA)
- Accessibility for Ontarians with Disability Act (AODA)

9.4 Town of Tillsonburg Permits and Approvals

Utility agencies shall apply and secure all necessary permits and approvals from the Town prior to commencement of any works within the R.O.W.

Necessary Town approvals include but are not limited to the following:

- Municipal Consent
- Encroachment Permit
- Tillsonburg Hydro Inc. (If applicable)
- Other Applicable County of Oxford Approvals (Within County R.O.W.)

Proponents shall follow the appropriate procedures with each of the above listed permits and approvals.

All new utility infrastructure projects/installations to be constructed within Town R.O.W. will require a Municipal Consent approval from the Town for each Utility prior to installation.

9.5 Long Point Region Conservation Authority Permits and Approvals

Utility agencies shall apply and/or secure all necessary permits and approvals from the Long Point Region Conservation Authority (LPRCA) for any installations within LPRCA jurisdiction/regulation area, as applicable.

9.6 Composite Utility Plans

To ensure that conflicts are avoided among utilities, street trees, municipal services and driveways, the Proponent shall prepare a Composite Utility Plan (CUP) for all new subdivision developments.

The CUP shall indicate the location of all underground services and utilities.

9.7 Minimum Cover

The minimum depth of cover shall be 1.2m for underground utilities within Town R.O.W. and shall be measured from the street surface to the top of the installed duct or conduit, as per OPSD 2103.02.

When attempting to locate existing underground utilities, it must not be assumed that all utilities are at standard depth.

9.8 Alignment

In preserving the Town R.O.W. for present and future use, the Town coordinates its efforts to minimize the amount, while maximizing the efficient use, of underground space occupied by each utility.

All efforts shall be made when replacing existing or installing new infrastructure to be in accordance with the Standard Drawings in this manual and the Typical Cross-sections.

Alignments selected for proposed utility installations shall adhere to the following conditions:

- Alignment and location of any new plant should coincide and match with that of the existing plant if possible
- Alignments must be parallel or perpendicular to street property lines
- When installing underground services to the same customer, those services running in parallel alignments are required to share a common trench
- Joint trench details must be clearly illustrated on utility company drawings
- When abandoning a plant, the alignment should replace or be placed immediately adjacent to the existing plant
- A continuous alignment for the length of the installation is preferred
- New and existing plant will occupy one utility corridor per street
- Requirements for abandoning of structures and duct banks shall be at the discretion of the Town
- Abandon of structures and duct banks at the discretion of the Town

All efforts should be made to locate service connections and appurtenances out of the driveway. Final decision will be at the final approval/discretion of the Town.

The Town recognizes that existing utilities located within the R.O.W. may present obstacles in satisfying the conditions in this section. If a utility company has any concerns when selecting an alignment, the utility designer, in consultation with the Developer's Consulting Engineer, shall submit an alternate alignment for review and approval by the Town.

9.9 Utility Clearances

Standard utility clearances between underground utilities have been established to minimize conflict and ensure a safe work zone exists around each utility's equipment.

Any exceptions to this clearance will require approval from the Town and the affected utility or utilities.

Sewer and watermain construction often requires deep excavations with wider trenches to allow for extra shoring and safe working room.

With the added concern of shallower utilities collapsing into deeper sewer trenches, the Town places restrictive requirements on utilities, requiring a minimum horizontal clearance of 1.5m from all watermains including hydrants and 2.0m from sewer main lines. In addition, the Town reserves the right to require additional clearance under special circumstances.

All efforts shall be made when replacing existing or installing new infrastructure to be in accordance with the Typical Cross-sections Standard Drawings.

Table 1 represents the minimum clear separation between public utilities and municipal sewer and water services. The trench detail contained in this manual identifies separation within joint trenches.

Table 1. Minimum Clearances from Utilities

Condition	Clearance Required (m)
Minimum distance below ditch inverts (m)	0.90
Minimum vertical distance from Town/County-owned infrastructure (m)	0.60
Minimum horizontal distance from Town/County-owned infrastructure (hydrants, chambers, etc.) (m)	1.5
Minimum horizontal distance from Town/County-owned infrastructure (watermain) (m)	1.50
Minimum horizontal distance from Town/County-owned infrastructure (sanitary and storm sewers) (m)	2.00

9.10 Separation from Trees

To protect the longevity of R.O.W. trees, the following separation requirements shall be followed.

For clearance with existing street trees, the placement of vaults and other structures or the installation by open cut shall maintain the greater distance of:

- 1.5m measured at breast height (TBH) (1.4m high) from the main trunk
- Six times the tree trunk diameter (measured at breast height) from the main trunk of the tree at breast height from street trees

If utilities within developed areas are being installed within these clearances, the Contractor shall have a certified arborist inspect the tree and recommend installation methods (trenchless, air spade, etc.) that would minimize the health impacts.

9.11 Underground Structures

Underground structures shall be in accordance with OPSS, OPSD and the individual Utility Standards, latest versions.

The Town's primary concerns focus on the location of these structures within the R.O.W., capacity for adjustment and drainage provisions.

9.11.1 Location of Structures

To preserve utility corridor space for present and future needs, the Town requires that installation of precast structures:

- Have the longer side of the equipment aligned parallel to the property line
- Preferred location is to align the structure directly over top of a utility
- Maintain a minimum clearance from face of curb of 15.0m from street intersections. This requirement assists with ease of access and adequate visibility for vehicle traffic during maintenance activities
- Preferably, be located in the boulevard or curb lane of the roadway, so as to minimize disruptions during construction and maintenance activities
- Are not permitted within a lane entrance or intersection curb return areas

9.12 Surface Structures

The following sections detail loading and placement criteria of surface structures, including vaults and non-standard maintenance holes.

9.12.1 Loading Criteria

The Town requires that all structures are constructed in accordance with the latest version of industry standards for the suitable application.

9.12.2 Placement Criteria

Clearance shall be maintained near standard pedestrian sidewalk ramps / curb cuts so as not to block access during maintenance.

Alongside the aforementioned loading criteria, surface structures shall comply with the separation distances for utility vaults and structures as per Table 2.

Table 2. Minimum Clearances for Utility Vaults and Structures

Condition	Minimum Clearance (m)
Street Furniture	1.0
Fire Hydrants	1.5
Valves or Manhole Structures	1.5
Traffic Poles	1.0
Entrances	1.0
Awnings, Building Overhands, and Canopies	2.0
Other Utilities	Standard Clearances

9.12.3 Surface Criteria

The following shall apply to structures that are installed at surface:

- The maximum gap permitted for all grates shall be 13mm
- A minimum allowance for a 100mm vertical adjustment of the equipment is required to accommodate changes to street grade and settling
- Equipment must be located within the existing utility alignments and/or corridors and will not be permitted where proposed placement may inhibit the use of a future corridor or limit optimum use of such space

9.13 Poles and Anchors

The following section details the Town's design requirements for utility poles and anchors.

9.13.1 Location of Poles

When the relocation of an existing pole or addition of a new pole is required, the Proponent shall refer to the following criteria regarding pole locations. Noting that existing conditions will generally restrict available locations, best efforts shall be made to conform to the design requirements below.

Generally, pole locations shall be:

- At lot lines or projected lot lines

- A minimum 1.0m clear of vehicular crossings, fire hydrant, catch basins, and midblock crosswalks

9.13.2 Down Guy and Anchor

Placement of down guys and anchors shall maintain access to existing sidewalks, walkways, entrances and driveways without altering traveled routes or clearances. Distance from either side of the sidewalks shall be 1.0m.

A sidewalk guy must be installed with the anchor at a maximum distance of 0.3m (or as otherwise approved by the Town) from property line. The down guy and anchors (including extensions) shall conform to current AODA regulations and not impact pedestrian traffic on the sidewalk including providing a vertical clearance of 3.0m for any extensions over a sidewalk.



Section 10

Table of Contents

10	STORM SEWERS.....	1
10.1	General Requirements	1
10.2	Other Reference Documents.....	1
10.3	Mainline Sewer Design	1
10.3.1	System Layout	1
10.3.2	Drainage System Calculations	2
10.3.3	Design Flow	3
10.3.4	Rainfall Intensity.....	3
10.3.5	Time of Concentration.....	4
10.3.6	Contributing Drainage Area.....	5
10.3.7	Runoff Coefficients.....	5
10.3.8	Velocity	5
10.3.9	Manning’s Roughness Coefficient.....	7
10.3.10	Pipe Size.....	7
10.3.11	Pipe Grade.....	7
10.3.12	Pipe Requirements	7
10.3.13	Minimum Pipe Cover.....	7
10.3.14	Bedding and Backfill	8
10.3.15	Pipe Material	8
10.3.16	Pipe Deflection.....	9
10.4	Maintenance Holes	9
10.4.1	Type and Size	9
10.4.2	Spacing.....	9
10.4.3	Maintenance Hole Frame, Cover and Grate Requirements.....	10
10.4.4	Connections to Maintenance Leads	10
10.4.5	Adjustment Units.....	10
10.4.6	Benching and Pipe Opening Requirements	10
10.4.7	Drop Across Maintenance Hole	10
10.4.8	Drop Structures.....	10
10.4.9	Access Requirements	11



10.4.10	Joints	11
10.5	Catch Basins	11
10.5.1	Type and Size	11
10.5.2	Catch Basin Leads	12
10.5.3	Frame, Cover and Grate Requirements	12
10.5.4	Connections to Mainline Sewer	12
10.5.5	Adjustment Units	12
10.6	Private Drain Connections (PDCs)	12
10.6.1	Foundation Drain Connections	12
10.6.2	Connection Types	13
10.6.3	Minimum Pipe Size	13
10.6.4	Service Location	13
10.6.5	Minimum Service Cover	13
10.6.6	Service Material	13
10.6.7	Service Grade	13
10.6.8	Inspection Manhole/Cleanout	14
10.6.9	Marking and Plugging Requirements	14
10.7	Downspout Discharge	14
10.8	Culverts	14
10.9	Storm Sewer Inlet, Outlet and Special Structures	14
10.9.1	General	14
10.9.2	Storm Sewer Inlet	15
10.9.3	Storm Sewer Outlet	15



List of Tables

Table 1. Minor and Major System Design Components

Table 2: IDF Design Parameters

Table 3. Recommended Runoff Coefficients

Table 4. Manning's Roughness Coefficients

Table 5. Insulation of Storm Sewer and Services

Table 6. Maximum Spacing for Storm Maintenance Holes

Table 7. Minimum Drop Across Maintenance Hole

Table 8. Catch Basin Leads

10 STORM SEWERS

10.1 General Requirements

This manual has been prepared to provide Town staff, consulting engineers, contractors, developers and the general public with a common reference to ensure the consistent application of storm sewer drainage design in the Town.

The information provided is not intended to hinder innovation and is rooted on meeting performance requirements over the lifecycle of the infrastructure.

Detailed storm sewer design sheets are to be included in all subdivision and site plan development applications.

10.2 Other Reference Documents

All storm sewers and appurtenances shall be designed and constructed in accordance with the latest version of this manual as well as industry standards and best practices, including but not limited to:

- Ontario Provincial Standard Specifications (OPSS) and Ontario Provincial Standard Drawings (OPSD) prepared by the Ministry of Transportation (MTO)
- Ministry of the Environment (MECP as amended) Design Guidelines for Sewage Works
- Ministry of the Environment (MECP) Stormwater Management Planning and Design Manual
- Ministry of Transportation (MTO) Highway Drainage Design Standards

10.3 Mainline Sewer Design

This section outlines the minimum requirements to aid the Proponents in the design of minor and major storm systems in the Town.

10.3.1 System Layout

All catch basin leads shall be placed at a minimum of 1% grade. All benching and pipe opening alternatives shall be designed in accordance with OPSD 701.0210. All changes in flow direction shall utilize a maintenance hole. Pipes 1050 mm and larger shall not exceed a maximum change in direction of 45°. Easements shall be avoided where feasible. Where an easement is deemed to be required, the width for the easement will be reviewed and approved by the Town.

10.3.1.1 New Development

Storm sewers shall be located in accordance with the Town’s Standard Drawings and Typical Cross-Sections as part of Appendix A of this manual. Where this location cannot be provided, the Proponent shall submit a suitable alternative for the Town’s approval.

Storm Sewers shall be terminated with a maintenance hole at the subdivision limits when external drainage areas are considered in the design.

10.3.1.2 Existing Infrastructure

Location of replacement storm sewers shall be determined specifically based on the location of existing utilities and other site conditions. All efforts shall be made to design in accordance with the Town’s Standard Drawings and Typical Cross-Sections as part of Appendix A of this manual.

10.3.1.3 Horizontal and Vertical Separation

Clearances between watermains, sanitary and storm sewers shall be based on the MECF Procedure F-6-1: Procedures to Govern the Separation of Sewers and Watermains.

The Town prefers a minimum horizontal separation of 2.5 m from outer wall of adjacent sewers and a minimum vertical separation of 500mm. The Proponent shall ensure that the excavation of storm sewer utilizing an open cut method will not disturb the bedding of neighbouring infrastructure.

10.3.2 Drainage System Calculations

The urban stormwater drainage system consists of the minor system and the major system, as outlined in Table 1.

Table 1. Minor and Major System Design Components

	Minor System	Watercourse and Culverts	Major System
Objective	To convey minor events and prevent nuisance flooding.	To convey larger storm events and prevent road flooding.	To reduce risk to life and property damage.
Design Storm Frequency	1 in 5 year	1 in 25 year	1 in 100 year

Under special circumstances and at the discretion of the Town, a higher design storm frequency (e.g. 1 in 10 year) may be required for the minor. Consultants are therefore required to consult with Town staff prior to the commencement of detailed storm sewer design for any project.

Consultation with the Town will be required if a trunk sewer that drains multiple developments is being considered.

Town may request a Hydraulic Grade Line Design/Calculation when storm PDC's are connected to the storm sewer.

10.3.3 Design Flow

Storm sewers shall be designed to collect stormwater runoff from pervious and impervious surfaces both on private and public lands.

Storm sewers shall be designed to accommodate a minimum 5-year design flow (see Table 1 above) without surcharge. The capacity of the sewer shall be determined on the basis of the pipe at or below 80% full flow. Design flow rates shall be sized using the Rational Method as follows:

$$Q = \frac{CIA}{360}$$

where,

Q = peak flow (m³/s)

C = runoff coefficient (dimensionless)

I = average rainfall intensity (mm/h)

A = contributing drainage area (hectares)

Design flows for storm sewer networks shall be calculated using the Rational Method for each maintenance hole reach and shall be submitted to the Town using the Storm Sewer Design Sheet provided in Appendix A of this manual.

10.3.4 Rainfall Intensity

The Rainfall Intensity (“I”) shall be based on the Intensity-Duration-Frequency (IDF) curves provided below. It should be noted that IDF curves are subject to review and may be altered from time to time to more accurately represent local trends in rainfall patterns, including impacts due to climate change.

For most residential and industrial developments, the rainfall intensity shall be determined from the formula indicated on the IDF Curve chart for the respective storm for the 1 in 5-year storm.

Under special circumstances the Town may request a 1 in 10-year storm be used to determine rainfall intensity for major trunk sewers.

Table 2: IDF Design Parameters

Parameter	Rainfall Intensity (mm/h)					
	2 Year	5 Year	10 Year	25 Year	50 Year	100 Year
A	21.4	28.3	32.8	38.5	2.7	46.9
B	-0.675	-0.662	-0.656	-0.651	-0.647	-0.645

The rainfall intensity shall be determined using the formula as follows:

$$i = A \times t_c^B$$

where,

i = rainfall intensity (mm/h)

t_c = time of concentration (minutes)

A and B are IDF values (dimensionless)

10.3.5 Time of Concentration

The time of concentration (t_c) shall be 15 minutes for most low density residential, open spaces, industrial, commercial and medium to high density residential.

For undeveloped lands upstream or external rural drainage, the Consulting Engineer shall calculate the initial time of concentration for upstream, undeveloped land utilizing the Airport Method Equation or the Bransby Williams Formula as per the MTO Drainage Manual, and provide documentation supporting the calculations.

In watersheds with a runoff coefficient, C, greater than 0.40, the Bransby Williams formula a typically accepted method. The Bransby Williams Formula is as follows:

$$t_c = \frac{0.057 \times L}{S_w^{0.2} \times A^{0.1}}$$

where,

t_c = time of concentration (minutes)

A = area (square metres)

L = watershed length (metres)

S_w = watershed slope (%)

For watersheds where the runoff coefficient, C, is less than 0.40, the Airport formula gives a better estimate of time of concentration. The Airport Method Equation is as follows:

$$t_c = \frac{3.26 \times (1.1 - C) \times L^{0.5}}{S_w^{0.33}}$$

where,

t_c = time of concentration (minutes)

C = runoff coefficient (dimensionless)

L = watershed length (metres)

S_w = watershed slope (%)

10.3.6 Contributing Drainage Area

The Drainage Area (“A”) shall be determined based on the proposed general area grading plans (and using available contour mapping for upstream unplanned and undeveloped lands).

When the design abuts undeveloped areas, the Consulting Engineer shall review and confirm the external watershed limits.

Any deviations to the existing mapped areas shall be reviewed and approved by the Town and the Long Point Region Conservation Authority (LPRCA). Areas, coefficients and times of concentration shall be shown for all drainage areas within external watershed limits.

10.3.7 Runoff Coefficients

The runoff coefficient (“C”) is based on the relative perviousness of the drainage area and varies based on the type of land use. Mixed land uses and reconstructions will require a composite (blended) runoff coefficient based on an area-weighted average of coefficients to represent specific land uses. The typical runoff coefficients are outlined in Table 3.

Table 3. Recommended Runoff Coefficients

Land Use	Runoff Coefficient
Parks, open spaces, and grassed areas (greater than 2 hectares)	0.20
Parks, open spaces, and grassed areas (less than 2 hectares)	0.25 – 0.35
Single family/semi-detached	0.45 – 0.6
Townhouses/rowhouses	0.65 – 0.8
Apartments	0.65 – 0.8
Commercial/Industrial	0.80 - 0.90
Impervious	0.95
Roof top storage	1.00

10.3.8 Velocity

The flow velocity shall be determined using the following formula:

$$V = \frac{Q}{A}$$

where,

v = flow velocity (m/s)

Q = design flow (m³/s)

A = cross-sectional area of flow (m²)

Flow velocities for storm sewers shall meet the following requirements, in accordance with MOE Guidelines:

Minimum full flow velocity = 1.0 m/s (transport solids and avoid deposition)

Maximum full flow velocity = 4.5 m/s for 300mm to 825mm diameter sewers

6.0 m/s for 900mm diameter or larger sewers

To determine velocities based on actual flow, the Consulting Engineer shall refer to the Town's Storm Sewer Design Sheet that includes the roughness coefficient required for Manning's Equation calculations.

$$Q = \frac{1}{n} \times A \times R^{\frac{2}{3}} \times S^{\frac{1}{2}}$$

Q = design flow (m³/s)

n = Manning's roughness coefficient

A = cross-sectional area of flow (m²)

R = hydraulic radius (area of flow / wetted perimeter)

S = slope of pipe (m/m)

10.3.9 Manning’s Roughness Coefficient

The Consulting Engineer shall use values for Manning’s Roughness Coefficients from Table 4.

Table 4. Manning’s Roughness Coefficients

Pipe Type	Manning’s Roughness Coefficient
Smooth walled pipe, all sizes and materials	0.013
Corrugated culvert pipe, all sizes and materials	0.024

10.3.10 Pipe Size

Pipe size shall be determined using Manning’s Formula. The capacity of the storm sewer shall be determined on the basis of the pipe at or below 93% full flow of the pipe during the selected design storm event. Percentage of pipe full shall be displayed on Storm design sheet. The minimum size for a mainline storm sewer shall be 300mm, regardless of the type of land use. The minimum size for a catch basin lead shall be 250mm.

No decrease of pipe size from a larger upstream pipe to a smaller downstream pipe will be permitted regardless of increase in grade.

10.3.11 Pipe Grade

The minimum pipe grade shall be 1% on the first leg of the sewer wherever possible to achieve a self-cleaning velocity of 1.0 m/s within the storm sewer wherever feasible. The remaining system shall not be less than 0.5% and as required to achieve the minimum velocity as stated above unless specifically approved by the Director of Operations and Development and Development.

10.3.12 Pipe Requirements

The pipe and appurtenances identified in this manual refer to conventional, open cut installation methods.

Alternative infrastructure installation methods will be submitted to the Town for review prior to design completion.

10.3.13 Minimum Pipe Cover

The minimum depth of cover shall be 1.5m from the finished grade to the top of the pipe. Additional depth may be required in areas where there is potential for conflict with other underground infrastructure.

Where the minimum specified cover of 1.5m on storm sewer cannot be achieved, sufficient insulation to prevent freezing of such sections of storm sewer shall be provided as specified in Table 5.

Table 5. Insulation of Storm Sewer and Services

Depth of Cover (m)	Thickness of Insulation (R5) (mm)	Width of Insulation (m)
1.20 to 1.50	50	1.2
1.05 to 1.19	65	1.2
0.90 to 1.04	75	1.5

10.3.14 Bedding and Backfill

Bedding material (and embedment for flexible pipes) shall consist of Granular ‘A’ unless saturated trench conditions are encountered and then bedding shall be 19mm clear stone and entirely wrapped in geotextile as per the Town’s Standard Drawings in Appendix A.

Trenches, bedding, embedment / cover and backfill to be in general conformance with applicable OPS drawings (OPSD 802.010 – 802.034).

Bedding, cover and embedment materials shall meet OPSS and be placed and compacted in accordance with Town’s Standard Drawings.

Bedding, embedment and cover materials shall be placed for the full width of the trench and mechanically compacted to 98% SPMDD, as determined by ASTM.

Backfill shall be considered as starting at 300mm above the storm sewer.

10.3.15 Pipe Material

Both rigid and flexible pipe complete with bell and spigot connections shall be permitted in the construction of storm sewer systems including private drain connections and catch basin leads. These materials include concrete, PVC and double walled HDPE.

On Private property, material for storm building sewers and private sewer shall comply with Part 7 of the OBC.

Circular concrete pipe and fittings shall conform to OPSS 1920. Non-reinforced concrete pipe shall be according to CSA A267.1. Reinforced Concrete pipe shall be according to CSA A257.2. Joint and gaskets shall be according to CSA A257.3.

PVC pipe and fittings complete with bell and spigot joints, rubber gasket, lubricant and all necessary appurtenances shall be manufactured in conformance with OPSS 1841 and shall be certified to either CSA B182.2 for PVC sewer Pipe and Fittings or B182.4 for Profile PVC Sewer Pipe and Fittings. PVC pipe shall have a minimum pipe stiffness of 320kPa. The maximum size of PVC pipe shall be 450mm diameter; anything greater shall be concrete pipe.

No Ultra-Rib pipe shall be installed within the Town right-of-way unless with Town approval.

In determining the suitable pipe class to be used, live load, dead load, soil type and trench conditions in accordance with OPSD 802 Series shall be considered in the calculation. The pipe manufacturer's recommendations shall be incorporated into the design.

10.3.16 Pipe Deflection

Maximum pipe deflection (for flexible pipes) from combined live and dead loading shall not exceed the more stringent of OPSS 410 or the pipe manufacturer's recommendations and shall be confirmed via mandrel testing, as per OPSS 410. The Town shall be notified regarding testing and results.

10.4 Maintenance Holes

Maintenance holes shall be in accordance with OPSS and OPSD 701 Series. Maintenance holes shall be located at changes in alignment, grade, pipe size, material, at pipe junctions. There is a maximum permitted spacing of maintenance holes for storm sewers based on the diameter of pipe as outlined in Table 6 - Maximum Spacing for Storm Maintenance Holes. Wherever possible, maintenance holes placed in the travel portion of roadways shall not be placed in vehicle wheel paths.

10.4.1 Type and Size

Maintenance holes shall be precast concrete structures. Under special circumstances, designs using cast-in-place concrete will be considered.

Maintenance holes shall be provided with monolithic bases and watertight joints. Adjustment units shall be provided where grade adjustments are necessary and shall be in accordance with OPSS.

10.4.2 Spacing

The maximum spacing distance between each storm maintenance hole shall be in accordance with the spacing requirements specified in Table 6.

Table 6. Maximum Spacing for Storm Maintenance Holes

Pipe Size (mm)	Maximum Spacing (m)
300 to 975	90
1050 to 1200	120
Greater than 1200	As approved by the Town

10.4.3 Maintenance Hole Frame, Cover and Grate Requirements

Maintenance hole frame and covers are required for all maintenance holes and shall be in accordance with OPSD 401.01 and applicable OPSS.

10.4.4 Connections to Maintenance Structure

Flexible storm sewers shall be connected to maintenance holes using Town approved adaptors. Connections for rigid pipe shall be fixed in place.

10.4.5 Adjustment Units

Maintenance holes shall be designed to include precast concrete adjustment units and shall be in accordance with OPSD 704.010.

10.4.6 Benching and Pipe Opening Requirements

Maintenance hole benching and pipe opening alternatives shall be designed in accordance with OPSD 701.021.

A Benching detail is required should the design deviate from OPSS.

10.4.7 Drop Across Maintenance Hole

The minimum drop across a maintenance hole shall be based on the change in direction of the inlet and outlet pipes as outlined in Table 7.

Table 7. Minimum Drop Across Maintenance Hole

Change in Direction, Θ	Minimum Drop Across Maintenance Hole (mm)
0°	25
Less than or equal to 45°	50
Greater than 45°	90

10.4.8 Drop Structures

Drop structures shall be provided in maintenance holes when the difference in elevation between the invert of the inlet and the bottom of the maintenance hole is greater than 0.9 m. Drop structures shall be external and designed in accordance with OPSD 1003.010. Internal drop structures may be considered on a case-by-case basis and shall be designed to OPSD1003.030 and accommodate person access.

10.4.9 Access Requirements

10.4.9.1 Steps

Design of steps shall be in accordance with OPSD 405.020.

10.4.9.2 Safety Landings

Safety landings shall be in accordance with OPSD 404 Series.

10.4.10 Joints

All joints below the groundwater level shall be sealed using a bituminous sealant tape.

10.5 Catch Basins

Catch basins shall be in accordance with OPSS and OPSD 400 Series. Catch basins shall generally be located upstream of all pedestrian crossings and upstream of intersections where the road grade falls towards the intersection. Catch basins shall not be located on walkways or driveway entrances/aprons, if possible.

Double catch basins shall be required at low points where drainage is received from more than one direction.

The design of the catch basin location and type shall take into consideration the drainage areas, road grades and intersection locations.

The maximum spacing distance between each catch basin shall be 90m in two (2) lane roads and 60m in four (4) lane roads. The location and layout of storm maintenance holes and catch basins shall be reviewed and approved by the Town. The Consultant shall ensure that the catch basin spacing is adequate to collect the storm water.

Due to maintenance issues rear yard catch basins are typically not permitted by the Town except when other options are not feasible. Wherever possible, site grading shall be designed in such a way that rear yard catch basins are not required.

10.5.1 Type and Size

Catch basins shall be precast concrete structures. Under special circumstances, designs using cast-in-place concrete will be considered. No curb inlet catch basins or set back catch basin are allowed.

Adjustment units shall be provided where grade adjustments are necessary and shall be in accordance with OPSS.

10.5.2 Catch Basin Leads

The minimum size and slope of catch basin leads for single, double and rear lot catch basins shall be in accordance with Table 8 - Catch Basin Leads.

Table 8. Catch Basin Leads

Catch basin Type	Minimum Connection Size (mm)	Minimum Grade (%)	Minimum Velocity (m/s)
Single	250	1.0	1.0
Rear Lot	300	0.8	1.0
Double	300	1.0	1.0

10.5.3 Frame, Cover and Grate Requirements

Frames, covers and grates shall be constructed in accordance with OPSD 400.02 and applicable OPSS. Catch basin grates shall be bicycle-proof.

10.5.4 Connections to Mainline Sewer

Catch basins located in close proximity to a manhole (< 10m) shall have their leads connected to the manholes. The Town's preference is to have connections directly into the manhole wherever possible in accordance with OPSS 410.

10.5.5 Adjustment Units

Catch basins shall be designed to include precast concrete adjustment units and shall be in accordance with OPSD.

Alternative materials on collector and arterials roads may be accepted on a case by case basis as approved by the Town.

10.6 Private Drain Connections (PDCs)

10.6.1 Foundation Drain Connections

The Town requires that all single family, semi and townhouse residential development applications include a foundation drain connection to the local storm sewer lateral via a sump pump with a gooseneck and air break. The foundation drains shall not be connected by gravity to the PDC.

If no local storm sewer lateral is available, then the sump pump shall discharge via a concrete splash pad to a grassed area away from the house avoiding driveways, walkways and adjacent properties.

10.6.2 Connection Types

Connections to storm sewers shall be made using pre-manufactured tee fittings.

Storm sewer PDCs shall not be connected directly to maintenance holes or catch basins. Connections shall be made using long sweep elbows and tees or wyes.

Connections shall not be made by breaking through the pipe wall on site, unless approved by the Town in existing infrastructure in accordance with OPSS 410.

10.6.3 Minimum Pipe Size

Storm PDCs shall have a minimum pipe size of 125mm.

One storm sewer lateral is permitted per dwelling unit for semis and townhome complex.

PDCs for multi residential applications larger than townhome complex shall be minimum 300mm shall be white PVC DR 35

10.6.4 Service Location

The location of the storm lateral is shown in the Town's Standard Drawings in this manual.

Cross connection of storm PDCs to any sanitary or combined sewer will not be accepted.

10.6.5 Minimum Service Cover

Storm sewer PDCs shall have a minimum cover of 1.2m at the property line from finished grade to the top of the pipe.

The minimum clearance to a watermain shall be 0.5m vertically

10.6.6 Service Material

PDCs shall be white PVC DR 35.

10.6.7 Service Grade

The grade of the storm sewer lateral shall range between a minimum and maximum of 2% and 8%, respectively.

Connections to mainline storm sewers consisting of rigid or flexible pipe shall be made at 10 and 2 o'clock (along the top of the pipe) using long sweep elbows.

10.6.8 Inspection Manhole/Cleanout

For institutional, commercial and industrial properties an inspection maintenance hole shall be located on the property line for access to the public side service lateral. The maintenance hole shall be installed flush to grade and equipped with a metal lid. For residential lots, the storm PDC shall be equipped with a cleanout at the property line. The cleanout shall be installed flush to grade with hard surfaces and equipped with a screw down metal lid. For soft surfaces, the cleanout shall be buried in topsoil to a depth of 150mm and shall be equipped with a metal lid for locating purposes.

10.6.9 Marking and Plugging Requirements

Plugged or capped service laterals shall be provided with an end cap and be marked with white paint and with adhesive tape labeled "CAUTION STORM SEWER". The location of the PDC shall be stake at the surface.

The service lateral shall be capped 0.3m inside of property line.

10.7 Downspout Discharge

Downspouts shall discharge into side yard swales via concrete splash pads. Downspouts shall not discharge onto driveways or walkways.

Commercial, industrial and high-density residential building sites may not have the ability to discharge to landscaped areas, therefore, the storm water roof drainage may be discharged directly into a storm sewer system given that flow control shall be applied where deemed necessary.

10.8 Culverts

Culverts shall be in accordance with MTO's Highway Drainage Design Standards, OPSS and OPSD.

The minimum culvert size shall be 450mm dia.

Approved pipe materials for culverts are as follows:

- Corrugated Steel Pipe (Aluminized)
- Concrete

10.9 Storm Sewer Inlet, Outlet and Special Structures

10.9.1 General

Inlet and outlet structures shall be designed and included on the engineering drawings. The details provided shall include the existing topography, proposed grading and the work necessary to protect against erosion.

10.9.2 Storm Sewer Inlet

For other than minor swales, the grates on inlet structures generally consist of inclined parallel bars or rods set in a plane at between 4:1 and 2:1 with the top furthest away from the direction of flow. Appropriately sized rip rap shall be provided at all inlets to protect against erosion and to channel the flow to the inlet structure.

10.9.3 Storm Sewer Outlet

The OPSD 800 Series Standard Headwalls shall be used for all storm sewers up to 1800mm. For sewers over 1800mm in diameter, the headwalls shall be individually designed. All headwalls shall be equipped with OPSD 804.05 grating over the outlet end of the pipe. Handrails shall also be installed at the top of all headwalls with grade differences greater than 0.6m from top of headwall to pipe invert. Alternate outlet designs will be considered on a specific basis.

All outlets shall bend in the direction of flow of the watercourse with the directional change being taken up in the sewer rather than the channel.

Erosion protection shall be provided at all outlets to prevent erosion of the watercourse and to the area adjacent to the outlet. Typically rip rap has been utilized but innovation is encouraged to create a naturalized appearance. The extent of the erosion protection shall be indicated on the engineering drawings and shall be dependent upon the velocity of flow in the storm sewer outlet, soil conditions, flow in the existing watercourse, site conditions and the requirements of the Long Point Region Conservation Authority, if applicable.



Section 11



Table of Contents

11	STORMWATER MANAGEMENT	1
11.1	General Requirements	1
11.2	Reference Documents	1
11.3	Objectives	1
11.3.1	Stormwater Quantity Objectives	2
11.3.2	Stormwater Quality Objectives	2
11.4	Water Balance	2
11.5	Low Impact Development	3
11.6	Municipal Drain Considerations	3
11.7	Requirements for Stormwater Management Report	3
11.8	Stormwater Model Guidelines	4
11.9	Rainfall Design Storms	4
11.10	Stormwater Management Pond Design Criteria	5
11.10.1	Inlet and Outlet Structures	5
11.10.2	Maintenance Access Roads	5
11.10.3	Sediment Drying Area	5
11.10.4	Slopes and Embankments	6
11.10.5	Emergency Overflow Spillway	6
11.10.6	Overland Flow Routes	6
11.10.7	Orifice Size	6
11.10.8	Vegetation and Plantings	6
11.11	Requirements for Erosion and Sediment Control During Construction	7
11.12	Commissioning Considerations	8
11.12.1	Maintenance and Monitoring Prior to Assumption	8
11.12.2	Operation Prior to Assumption	8
11.12.3	Operation and Maintenance Manual	8

List of Tables

Table 1. IDF Design Parameters

11 STORMWATER MANAGEMENT

11.1 General Requirements

This section covers the recommended approach for the design, analysis and implementation of the stormwater management (SWM) systems for residential, commercial, institutional and industrial developments within the Town of Tillsonburg. The purpose of this section is to outline the recommended criteria for stormwater management system design that will ultimately be assumed by the Town and should be read in conjunction with Section 10 – Storm Sewers.

Prior to initiating the preparation of the stormwater management, the Proponent must consult with the Long Point Region Conservation Authority (LPRCA) and the Town of Tillsonburg on the stormwater management criteria that shall be utilized in the design and analysis of the development. Criteria issued by these agencies shall be applied to the design of the SWM system.

Detailed stormwater design sheets are to be included in all subdivision and site plan development applications.

11.2 Reference Documents

All stormwater management systems shall be designed and constructed in accordance with the latest version of this manual, as well as other industry standards and best practices, including but not limited to:

- Ontario Provincial Standard Specifications (OPSS) and Ontario Provincial Standard Drawings (OPSD) prepared by the Ministry of Transportation (MTO)
- Stormwater Management Planning and Design Manual (current revision – 2003) prepared by the Ministry of the Environment Conservation and Parks (MECP)
- Erosion and Sediment Control Guidelines for Urban Construction (current revision – 2006) prepared by the Greater Golden Horseshoe Area Conservation Authorities
- The Low Impact Development Stormwater Management Planning and Design Guide prepared by the Toronto and Region and Credit Valley Conservation Authorities

11.3 Objectives

The stormwater management system for each development shall satisfy the following objectives:

1. Ensure compliance with all applicable Town requirements, standards, provincial guidelines
2. Maintain and promote low impact, sustainable stormwater management for the expanding urban system

3. Ensure implementation of safe, environmentally conscience, easily maintained, and cost-effective stormwater management facilities

11.3.1 Stormwater Quantity Objectives

A distinction shall be made between developments within a new planning area and those developments occurring established neighbourhood. The distinction shall be made by the Town of Tillsonburg in conjunction with other regulatory agencies, such as the LPRCA.

The stormwater management design for developments within new planning areas shall implement the recommendations of the pre-consultation with LPRCA and the Town of Tillsonburg. Typically, the development shall be required to control all post-development flows to the corresponding pre-development flow rates (greenfield) unless otherwise stated in a previously completed subwatershed master plan. Should the development fall within a subwatershed master plan, the development shall control flows according to the allocated flows specified.

The stormwater management system design for developments occurring in an established neighbourhood shall control all post-development flows to the corresponding pre-development flow rate unless the lands have already been included in existing completed downstream SWM facilities, or as otherwise directed by the Town or LPRCA. The site must be designed to detain sufficient volumes on-site in order to ensure that post-development peak flow rates do not exceed pre-development flow rates for the same design storm events, and to ensure existing downstream infrastructure and conveyance systems are not surcharged, resulting in flooding and significant damages.

All developments shall be designed to safely convey overland flows to an adequate outlet.

11.3.2 Stormwater Quality Objectives

For all residential, commercial, institutional and industrial developments, the Town requires Enhanced Water Quality Protection (80% Total Suspended Solids Removal) as described in the Stormwater Management Planning and Design Manual prepared by the MOE (2003) prior to discharge from the site to the receiving outlet.

Where there is a potential for spill contamination, developments are to provide an appropriate containments and pretreatment prior to discharging from the site to a stormwater management facility. Only “clean” runoff shall be allowed to be infiltrated.

Should the development be located within a Source Water Protection Zone, consultation with LPRCA, Oxford County and the Town will be required prior to design of any infiltration systems.

11.4 Water Balance

Best Management Practices recommend that post-development groundwater recharge rates replicate pre-development rates within new urban development. Groundwater recharge shall only occur however in areas deemed appropriate by the Town, Oxford County, LPRCA, and MECP.

A site-specific water balance calculation shall be completed using the water balance method as documented in the MOE's Stormwater Management Planning and Design Manual. Infiltration facilities shall be designed to ensure that the annual infiltration volume for the post-development condition matches the volume for the pre-development condition.

11.5 Low Impact Development

The Town encourages innovative use of Low Impact Development (LID) devices for stormwater management systems both for new development and infill/brownfield re-developments where feasible. LID practices include the incorporation of "green infrastructure" such as infiltration basins, green roofs, bioretention swales, and other conveyance swale methods within the municipal stormwater management facility as well as specific installations within stormwater facility block.

The installation and implementation of LID systems within the stormwater facility block shall be subject to consultation and approval with the Town (and County if applicable) prior to approval and installation. These LID systems are to be low maintenance and cost-effective. The Developer shall provide an estimated maintenance cost schedule analysis for the lifetime of the proposed LID system to the Town.

Draft Operations and Maintenance manuals for any LID systems that the Town will assume shall be provided to the Town for review prior to approval.

Should the development fall within Source Water Protection Zones, consultation with LPRCA, Oxford County and the Town will be required prior to design of LID systems.

11.6 Municipal Drain Considerations

Stormwater management systems that outlet to a municipal drain shall control the allowable run-off rates from the development to the specified allotted run-off or contributing flow in the most recent version of the municipal drainage report.

Should the municipal drain outlet prove to be insufficient, the consultant shall follow the appropriate process as outlined in the Municipal Drainage Act to establish a sufficient outlet.

In situations where stormwater is to outlet to a municipal drain, consultation with the Town and LPRCA will be required prior to the design of the system.

11.7 Requirements for Stormwater Management Report

The requirements for quantity and quality control of stormwater run-off management and supporting report or criteria shall be assessed on an individual project basis.

Design concepts for stormwater management facilities and designs will generally (after consultation with the Town of Tillsonburg, and LPRCA) follow the reference documents listed above and shall be subject to the above-mentioned review agencies.

Generally, all Stormwater Management Reports are to include:

- Reports must be signed and sealed by a Professional Engineer in accordance with the Professional Engineers Ontario “Use of the Professional Engineer’s Seal Guideline.”
- SWM designs may incorporate innovative approaches, provided the intent of the SWM system requirements and criteria are achievable and sustainable.
- Shall establish the minor-major storm event drainage concept for the development and shall demonstrate the ultimate outlet for the development.
- SWM designs to include flow calculations (Flow and Max Depth) of all overland drainage areas, rear yard swales, and any significant drainage feature.
- The water balance evaluation and calculations shall include an assessment of existing conditions and recommended measures to mitigate the impact to the water balance under post development conditions.
- The report shall establish defined pre and post development catchment areas with the following parameters: Soil type, corresponding soil number used in hydraulic equations, land coverage type, previous and future use, overall slope and how each catchment relates to each other. This will also be accompanied with a catchment area drawing for pre and post development.

11.8 Stormwater Model Guidelines

For all developments, hydraulic models may be required by the Town.

OTTHYMO, PC-SWMM, Autodesk Storm and Sanitary Analysis (SSA), and Visual OTTHYMO are the simulation models preferred by the Town of Tillsonburg; however, other models may be acceptable to the Town.

11.9 Rainfall Design Storms

For stormwater management system design and modelling the design storms shall be a 3-hour Chicago-type storm distribution based on the IDF curves below.

The Regional Storm event to be used shall be Hurricane Hazel (1954).

Table 1: IDF Design Parameters

Parameter	Rainfall Intensity (mm/h)					
	2 Year	5 Year	10 Year	25 Year	50 Year	100 Year
A	21.4	28.3	32.8	38.5	2.7	46.9
B	-0.675	-0.662	-0.656	-0.651	-0.647	-0.645

11.10 Stormwater Management Pond Design Criteria

11.10.1 Inlet and Outlet Structures

Inlet and outlet structures shall be designed for ease of maintenance. The inlet and outlet structures shall be designed to prevent debris and the public from entering the structures.

Inlet structures shall be installed to match the designed water levels and shall include a headwall or pipe structure as per OPSD 804 Series. Appropriate sized and designed erosion protection shall be provided to prevent erosion and scouring. The protection shall be the full width of the inlet and outlet structure and shall be selected to withstand the anticipated velocities.

11.10.2 Maintenance Access Roads

Maintenance access roads shall be required from the municipal right of way to all aspects of the SWM facility, specifically the inlet structure, outlet structure and the sediment forebays. Dead end maintenance access roads shall not be installed unless approved by the Town for site specific restrictions.

The maintenance roads shall be a minimum of 3.5m in width. The cross fall for the access road shall be 2% - 4% with a longitudinal gradient between 2% - 6%.

The access connecting the SWM facility from the ROW shall be a minimum of 6.0m in width.

The maintenance access road shall incorporate suitable turning radii for Town vehicles and shall have an asphalt surface A Geotechnical Engineer to provide granular and asphalt structure.

11.10.3 Sediment Drying Area

A sediment drying area shall be provided immediately adjacent to the maintenance access road and to the sediment forebay to facilitate ease of access for sediment removal from the forebay and sediment storage. The area should be graded to allow positive drainage to the forebay at a minimum slope of 2.0%. The sediment drying area shall be designed to facilitate the volume required for maintenance at 10 years. The drying area shall be rehabilitated at the time of maintenance.

11.10.4 Slopes and Embankments

Slopes and embankments shall compile with Stormwater Management Planning and Design Manual (MOE, 2003) and shall be sloped in order to protect the public.

11.10.5 Emergency Overflow Spillway

All SWM systems shall be designed with an emergency overflow spillway where applicable to allow for the safe storm drainage without impacting adjacent landowners in the event of a failure of the outlet structure or a storm event that exceeds the pond design.

The spillway shall maintain 0.3m of freeboard to the top of the facility perimeter berm under the regional design storm event. The invert of the spillway shall be set at the maximum ponding elevation obtained at the regional design storm event.

Erosion protection at the spillway shall be installed and sized to protect the structure from erosion during the regional event. The consultant shall ensure that the erosions protection is suitable for the anticipated velocities under the Regional design storm event.

11.10.6 Overland Flow Routes

Major overland flow should not be directed into the sediment forebay wherever possible to avoid resuspension of sediment.

Erosion protection at the spillway shall be installed and sized to protect the spillway from erosion during the regional design storm event. The consultant shall ensure that the erosion protection is suitable for the anticipated velocities during the regional design storm event.

Drying area not to be included in the Overland Flow Route.

11.10.7 Orifice Size

The preferred minimum orifice size acceptable for outlet control is 100mm diameter to prevent clogging.

All orifices devices shall be manufactured from non-corrosion material and shall be installed securely to the structure.

11.10.8 Vegetation and Plantings

Vegetation and Plantings for the SWM facility shall be selected by a licensed landscape architect and shall submit the proposed planting design drawing complete with species to the Town for approval.

The plantings within the SWM facility shall be all native species, ecologically selected and low maintenance. The perimeter of the SWM facility shall be native wild flowers as per Long Point Region Conservation Authority with the exclusion of Golden Rod .

No noxious weeds or plants shall be accepted within the proposed planting plan.

11.11 Requirements for Erosion and Sediment Control During Construction

The SWM report shall include the list of items below in terms of controlling erosion and the transport of sediment into natural watercourses during construction. However, since the list is intended to cover a broad range of development proposals, portions of the submission list may not be applicable for all development proposals.

- Erosion and Sediment Control Plans
- Erosion and Sediment Control Phasing
- Worksite Isolation Plan for In-stream Construction
- Spill Control and Response Plan
- De-watering plan
- Storm Drain Outfall Protection
- Storm Drain Inlet Protection
- Seeding/Sodding
- Sediment/Silt Control Fence
- Interception/Diversion Swales and Dykes
- Vehicle Tracking Control/Mud Mats
- Sediment Traps
- Rock Check Dams
- Temporary Sediment Control Ponds/Basins
- Topsoil Stockpiles
- Construction Access Mud Mats
- Restoration

11.12 Commissioning Considerations

11.12.1 Maintenance and Monitoring Prior to Assumption

Maintenance and monitoring of the SWM facility prior to the Town's assumption shall be carried out by the Developer to demonstrate the effectiveness of the performance of these facilities in accordance with the approved Environmental Compliance Approval (ECA). The proposed maintenance and monitoring plan shall be submitted to the Town prior to construction for review and approval.

The maintenance and monitoring and associated costs shall be the sole responsibility of the Developer until assumption by the Town.

Proportional cost sharing for maintenance and monitoring of the SWM facility will be evaluated amongst the benefiting developments on an individual case by case basis.

11.12.2 Operation Prior to Assumption

The Developer shall be responsible for the operation and maintenance of the SWM facility prior to assumption.

Prior to assumption the Developer shall be responsible for the dredging and removal of all sediment as a result of operation and construction activities. In addition, the Developer shall be responsible for the removal of any temporary protection measures installed for construction activities.

11.12.3 Operation and Maintenance Manual

Prior to assumption, the Developer shall submit an Operations and Maintenance Manual for the stormwater management facility to the Town for review and approval. This document shall detail typical operation and maintenance procedures to maintain a functional pond, including a detailed clean out procedure.



Section 12



Table of Contents

12	SANITARY SEWERS	1
11.1	General Requirements	1
11.2	Cleanouts	1
11.3	Pipe Deflection – Forcemains	1
11.4	Forcemain	1

12 SANITARY SEWERS

12.1 General Requirements

All sanitary collection and conveyance shall adhere to the County of Oxford Design Guidelines, Section 4, as well as the following modifications or additions specific to sanitary linear infrastructure installed within the Town of Tillsonburg.

12.2 Cleanouts

Cleanouts for sanitary Private Drain Connections (PDCs) shall be installed at property line, gasketed and shall be swept into soft surfaces wherever possible. The cleanouts shall have the following specifications:

- Soft surfaces – cleanout shall be buried with a metallic lid 150mm below the surface and covered with 150mm screened top soil and sod.
- Hard surfaces (if required) – PDCs shall be installed flush with the hard surface and equipped with a solid metal screw down lid.

12.3 Pipe Deflection – Forcemains

Section 4 Item Section 1.15 c) of the County of Oxford Design Guidelines shall be amended for infrastructure with the Town to the following:

On curves, the main location may deviate slightly from the standard by using half of the maximum allowable deflection in the pipe joints. Refer to manufacture's specifications regarding pipe deflection. A minimum number of special bends should be used.

12.4 Forcemain

All forcemains shall be installed with proper tracer wire and test stations. Test stations should be spaced sufficiently so a signal can be traced for 200-300m.

No forcemain within the Town shall be blue in colour.



Section 13



Table of Contents

13 WATERMAINS	1
13.1 General Requirements	1
13.2 Pipe Deflection	1
13.3 Thrust Blocks	1
13.4 Inspection	1

13 WATERMAINS

13.1 General Requirements

All watermains shall adhere to the County of Oxford Design Guidelines, Section 3, as well as the following modifications or additions specific to watermain infrastructure installed within the Town of Tillsonburg.

13.2 Pipe Deflection

Section 3 Item Section 1.1. c) of the County of Oxford Design Guidelines shall be amended for watermain with the Town to the following:

It is recognized that the above standards apply here straight runs are being installed. On curves, the main location may deviate slightly from the standard using a maximum of half the allowable deflection in the pipe joints. Refer to manufacturer's specifications regarding pipe deflection. A minimum number of special bends should be used.

13.3 Thrust Blocks

Section 3 Item Section 1.1. h) of the County of Oxford Design Guidelines shall be amended for infrastructure with the Town to the following:

The use of concrete thrust blocks is not permitted in the Town of Tillsonburg unless approved by the Town. All restraints shall be mechanical restraints as per Section 3 Item 1.1 h) of the Oxford County Standards.

13.4 Inspection

Town of Tillsonburg Operations staff shall be onsite for the entire duration of installation, testing and commissioning of watermain within the Town limits.



Section 14

Table of Contents

14	LOT GRADING	1
14.1	General Requirements.....	1
14.2	Other Reference Documents.....	1
14.3	Grading Requirements.....	1
14.3.1	New Subdivision Developments.....	1
14.3.2	Infill Lots.....	1
14.3.3	Town Capital Projects.....	2
14.4	Design Considerations.....	2
14.5	Drainage Surfaces.....	2
14.6	Major Overland Flow.....	3
14.7	Swales.....	3
14.7.1	Slope.....	3
14.7.2	Swale Lengths/Flows.....	4
14.7.3	Swale Depth.....	4
14.7.4	Plan Requirements.....	4
14.8	Elevations.....	4
14.9	Retaining Walls.....	4
14.10	Erosion and Sediment Control.....	5
14.10.1	Plan Requirements.....	5
14.10.2	Considerations.....	5
14.10.3	Erosion and Sediment Control Design.....	5
14.10.4	Drawings Notes.....	5
14.11	Approval and Certification.....	6
14.11.1	Lot Grading Approval.....	6
14.11.2	Foundation Control Certificate.....	8
14.11.3	As-Constructed Site Grading Plan/Final Grading Certificate.....	8
14.11.4	Municipal Infrastructure Deposit.....	9

14 LOT GRADING

14.1 General Requirements

This section outlines the recommended requirements for the design and implementation of lot grading for residential, industrial and commercial developments, as well as infill lots and municipal infrastructure renewal/rehabilitation projects.

The grading of all lots and blocks in new development must be carefully monitored by the Consultant to provide grades that are suitable for the erection of buildings and to provide satisfactory drainage from all lands within and outside the development. In this regard, the design of the grading for all developments will be of primary concern to the municipality and the following criteria shall be used in preparation of all lot grading plans for new developments. In applying the criteria, while maximum limits are specified, the main objective is to ensure that the property owner (i.e. Resident) will have maximum usage of their property while still providing good drainage. Consequently, the Town wishes to avoid designing to the maximum or minimum limits as specified unless all other options have been exhausted.

14.2 Other Reference Documents

Lot grading shall be designed and constructed in accordance with the latest version of this manual as well as other industry standards and best practices, including but not limited to:

- Guidelines on Erosion and Sediment Control for Urban Construction Sites, prepared by Ontario Ministry of Natural Resources
- Ontario Provincial Standard Specifications (OPSS) and Ontario Provincial Standard Drawings (OPSD) prepared by the Ministry of Transportation
- Ontario Building Code (OBC)
- Applicable Town of Tillsonburg By-Laws
- Accessibility for Ontarians with Disabilities Act (AODA)

14.3 Grading Requirements

14.3.1 New Subdivision Developments

Subdivisions created by a draft plan of subdivision shall conform to the lot grading standards within this section. The design will be implemented as to not negatively affect the drainage or usability of the abutting or adjacent properties.

14.3.2 Infill Lots

Developments created by severance or infill lots for residential lots shall conform to the lot grading standards and are not to negatively affect the abutting and/or adjacent properties.

14.3.3 Town Capital Projects

When grading is required, the Consultant or Designer shall determine match points that naturally blend proposed design grades with existing topography. Consideration shall be given to the following:

- Intersection streets
- Existing driveway profiles
- Existing drainage patterns
- Utilities structures
- Retaining wall structures
- Impacts on municipal and/or private trees (and other landscaping features)

Where ever possible the consultant or designer shall reduce the size or completely eliminate retaining wall structures owned or maintained by the Town.

Considerations shall be given to the maintenance and aesthetics of grassed areas such as lawns and boulevards.

14.4 Design Considerations

Lot drainage is to be self-contained within the limits of the subdivision. All medium and high density residential, commercial, and industrial drainage shall be contained within the block.

The boulevard and a minimum of 7.5m at the front of any residential lot must drain towards the abutting road.

All surface runoff shall be directed away from the house into defined swales which outlet to the street or rear yard swales.

Drainage from single dwelling lots may drain between other single dwelling lots in the same development when the drainage is contained in swales. (either rear or side yard).

14.5 Drainage Surfaces

All lot surfaces shall be constructed to a 1.7% minimum grade and a maximum of 8.0%.

Hard surfaces (i.e. patio and pool decks) within the rear yard of residential developments may be constructed to a 0.5% minimum grade.

The grade of driveways and walkways shall not exceed 8% maximum. Driveways shall not have a negative slope from the streetline to the building and shall have a minimum grade of 2% to provide positive drainage away from the building.

Berms and side slopes on swales and ditches shall have a maximum slope of 3 horizontal to 1 vertical.

Use of 3 horizontal to 1 vertical slopes shall be limited on residential properties and side yards to maximize functionality for the end user.

A 0.9m wide path sloping between 2% to 8.0% away from the building wall shall be constructed along one side of the building to allow proper access to rear yards.

A minimum distance of 0.6m from property line to remain unimpeded where a swale is located.

Within Industrial site a minimum grade of 1% for hard surface (Concrete, Asphalt) will be accepted within parking, storage and loading dock areas.

14.6 Major Overland Flow

Storm sewers are designed to accommodate storm runoff from a 5-year storm event, the lot grading design shall be designed to accommodate runoff from a major storm event that exceeds the capacity of the storm sewer system. This runoff shall be provided for in an effective major overland flow route from residential areas to an acceptable outlet location such as a storm water management facility.

Major overland flow routes shall follow low areas in subdivision grading.

All major overland flow shall be directed into storm water management facilities or appropriate outlet.

Ponding on roadways will not be allowed unless all other road grading options have been demonstrated to the Town and exhausted. Maximum allowable ponding at gutterline is 300mm. Ponding on sidewalk will not be allowed.

Building opening elevations adjacent to major overland flow routes through lots or blocks within a subdivision shall be at least 450mm above the major overland flow route elevation (i.e. no window wells).

The overland flow for major Regional design storm event (Hurricane Hazel) shall be accommodated in road cross-sections and/or on blocks of land dedicated to the municipality. The direction of the overland flow route shall be identified on all grading and/or drainage plans.

14.7 Swales

Drainage flows which are carried around houses are to be contained in defined swales located as far away from the foundation as feasible.

Driveways shall not be used as outlets for swales.

14.7.1 Slope

The minimum grade on all swales shall be 1.7%.

14.7.2 Swale Lengths/Flows

Maximum flow length for a rear yard swale is recommended to be 90m.

Side yard swales shall accommodate the flow from the contributing area.

14.7.3 Swale Depth

The minimum swale depth is recommended to be 0.15m and maximum swale depth is recommended to be 0.5m.

An average swale depth of 0.225m is recommended to be maintained throughout the development.

14.7.4 Plan Requirements

Swales shall be clearly identified on the design drawings including location, swale percentage and direction of flow (by means of arrows).

14.8 Elevations

Contours are to be shown on all master grading plans at an interval of 0.5m. Contours shall extend a minimum of 30m beyond the proposed development onto existing land.

Existing spot elevations shall be shown at all lot/block corners along the boundary of the development, and overland flow routes.

Centerline of road elevations shall be shown at 20m intervals, break points, beginning of the vertical curve (BVC), end of the vertical curve (EVC), low points and high points for all proposed roads within the development and existing roads around perimeter of site.

Proposed grades shall be shown at all lot corners, break points, high points, building corners, and the top and bottom of swales, ditches, slopes, and retaining walls.

Proposed curb and gutter grades shall be shown at edge of asphalt for all beginning of curves (BC), end of curves (EC), and breakpoints at intersection radii, elbows and cul-de-sacs. Additional grades shall be shown at 15m intervals (minimum) for elbows and cul-de-sacs.

For Infill lots elevations shall extend a minimum of 5m beyond the property line and pick up any and all structures within that.

14.9 Retaining Walls

Where a slope is greater than 3:1 (horizontal to vertical) a retaining wall will be required to make up the grade change between the two elevations. All design and specifications for retaining walls shall be in accordance with the Ontario Building Code.

All retaining walls 1.0m in height and greater shall be designed by a registered professional engineer in accordance with the Ontario Building Code.

Retaining walls 0.6m in height and greater shall have a railing installed along the top of the retaining wall in accordance with the Ontario Building Code.

All retaining walls within or adjacent to a road allowance shall be concrete material or engineered retaining wall systems, approved in writing by the Town.

All retaining walls within the lot or block may be concrete, engineered retaining wall systems or pressure treated wood material.

All retaining walls over 0.3m in height shall be offset a minimum of 1.0m from property lines.

14.10 Erosion and Sediment Control

14.10.1 Plan Requirements

An Erosion and Sediment Control Plan (ESCP) is required for all Capital Works and Development projects within the Town and shall address all requirements as outlined in this section.

Sediment and erosion control measures and notes are to be identified on all lot grading drawings, storm water management facility drawings, channels, outlet structure drawings and plan and profile drawings where applicable. If sediment and erosion control measures are extensive a separate drawing may be required at the request of the Town.

14.10.2 Considerations

The ESCP should address and consider all potential construction issues on any given project, including, but not limited to:

- Proximity to an open watercourse
- Proximity to woodlands, environmental sensitive area (ESA), naturalize areas
- Proximity to exiting drainage infrastructure
- Steep slopes susceptible to failure
- High groundwater levels

14.10.3 Erosion and Sediment Control Design

Erosion and Sediment Control Design shall comply with the Guidelines on Erosion and Sediment Control for Urban Construction Sites, prepared by the Ministry of Natural Resources. As well, the Proponent shall address all requirements set forth by the LPRCA (where applicable).

14.10.4 Drawings Notes

The following sediment control measure notes are to be shown on the construction drawings, either on the plan that details the sediment and erosion control measures, or on the notes and

details drawing. Please note that the following sediment control measure notes are examples only, and may be altered to suit the individual project:

- Protect all exposed surfaces and control all runoff during construction
- All erosion control measures are to be in place before starting construction and remain in place until restoration is complete
- Maintain erosion control measures during construction
- All collected sediment must be disposed of at an approved location
- Minimize area disturbed during construction. All dewatering must be disposed of in an approved sedimentation basin
- Protect all catch basins, maintenance holes and pipe ends from sediment intrusion with non-woven geotextile (Terrafix 270R or approved equivalent)
- Keep all sumps clean during construction
- Prevent wind-blown dust
- Straw bales to be used in localized areas as shown and as directed by the engineer during construction for works which are in or adjacent to floodlines, fill lines and hazardous slopes
- Straw bales to be terminated by rounding bales to contain and filter runoff
- Obtain approval from LPRCA prior to construction for works which are in, or adjacent to floodlines, fill lines and hazardous slopes
- All silt fencing and details are at the minimum to be constructed in accordance with the Ministry of Natural Resources Guidelines on Erosion and Sediment Control for Urban Construction Sites
- All of the above notes and any sediment & erosion control measures are at the minimum to be in accordance with the Ministry of Natural Resources Guidelines on Erosion and Sediment Control for Urban Construction Site

14.11 Approval and Certification

14.11.1 Lot Grading Approval

Prior to application for building permit, individual site grading plans for each lot shall be design by a Registered Professional Engineer (P.Eng.) or Ontario Land Surveyor (OLS) and approved by the Engineer of Record for the development and submitted to the Town for review. The Consulting Engineer or OLS shall ensure the site grading plan submitted for review by the Town is in conformance with the approved subdivision lot grading plan approved by the Town.

Where an infill or severed lot exists and there is no active developer of the subdivision then the site grading plans designed by a Registered Professional Engineer or OLS will be accepted by the Town.

The proposed site grading plan shall include the following:

- The name of the subdivision (if available)
- Include both municipal number and lot number if applicable
- Shall be to scale 1:250, on an 8.5x14 or 11x17 sheet
- All units in metric, dimensioned property limits, building location with ties to property lines
- All proposed easements required for registration
- Elevations for the following:
 - finished floor elevation
 - top of foundation
 - basement slab and underside of footing elevation
 - proposed grades at all lot corners
 - front and rear of building
 - break points
 - side yard and rear yard swale grades
 - grades at building corners
 - catch basin lid elevation
 - percent grades for driveways
 - garage finished floor and underside of garage foot elevations (FFE, USGE)
- All slopes labelled (3:1)
- Surface flow arrows with percent grades
- Retaining walls
- Door Locations
- Number of Risers

- Above ground utilities (streetlights, pedestals, etc.)
- Existing grades along all property limits of development
- Existing grades for all limits if for infill lot
- Existing and proposed vegetation/trees
- Underground utilities
- Stamped by a Professional Engineer or Seal from OLS

The approved site grading plan shall be submitted in triplicate with the building permit application, or as required by electronic submission.

14.11.2 Foundation Control Certificate

A Professional Engineer or OLS shall provide the Town of Tillsonburg Building Division with a foundation control certificate (see Appendix 14-1) confirming the foundation grade and layout is in conformance with the approved site plan/grading plan.

The foundation control certificate shall be reviewed by the Town of Tillsonburg Building Division before house construction proceeds beyond the basement level. Placement of finished floor prior to backfill only will be allowed to reduce potential for foundation cracking from backfilling.

This certificate shall include the following:

- The Professional Engineer or OLS shall confirm the footing and foundation elevations are in conformance with the approved lot grading plan and zoning bylaw
- An OLS shall provide the town with a building location survey confirming the foundations are in conformance with applicable zoning by-law

Any non-conformance of the foundation or site elevations shall be brought to the Town's attention for further direction prior to proceeding with any further construction. Exposed foundation heights are to be in accordance with the Ontario Building Code.

14.11.3 As-Constructed Site Grading Plan/Final Grading Certificate

An "As-Constructed" site grading plan shall be prepared, after final lot grading has been completed (preferably prior to sod/seed) and shall be submitted to the Consulting Engineer of record for approval to confirm the lot has been graded in conformance with the approved lot grading plan and shall be submitted to the Town. Final "As-Constructed" lot grades shall conform to the approved lot grading plan and shall be within the 100mm grading tolerance for all lot grading. All swale and lot surface gradients are required to be within the minimum and maximum allowable limits set forth in these guidelines or else may be rejected by the Town.

A final lot grading certificate (see Appendix 14-2) shall be prepared by the Consulting Engineer of record, certifying the lot grading has been checked and found to be in conformance with the approved site grading plan, overall subdivision lot grading plan and the Town's Guidelines.

Deck, shed and pool permits shall not be issued for individual lots until a final lot grading certificate has been certified and approved by the engineer of record and submitted to the Town or an amended lot grading plan is submitted to the Town showing the proposed changes for review/approval.

One (1) copies and PDF of the approved "As-Constructed" site grading plan and final lot grading certificate shall be forwarded to the Town immediately upon completion. The final lot grading certificate shall follow the format as provided by the Town.

14.11.4 Municipal Infrastructure Deposit

A refundable municipal infrastructure deposit as per the Rates and Fees By-law shall be submitted with the approved site grading plan at the time of building permit application where the builder is separate from the developer. Where multiple building permit applications by a single builder have been issued, the refundable municipal infrastructure deposit for the second and additional applications shall be half the municipal infrastructure deposit. The municipal infrastructure deposit for the first application will be held until the deposit can be released and there is at least one outstanding building permit issued to the builder.

In the event a builder is found to be in non-compliance of one of the items below then the Town has the right to require the full municipal infrastructure deposit per building permit application for the second and all additional building permit applications.

This municipal infrastructure deposit will be held by the Town until the following are in compliance:

- Curbs have been repaired in the event of damage caused by the builder; for infill lots or lots not within a current subdivision agreement.
- Sidewalks have been repaired in the event of damage caused by the builder; for infill lots or lots not within a current subdivision agreement.
- Water curb stop has been repaired adjusted to finished grade in the event of damage caused by the builder
- The builder shall provide confirmation the property bars are undisturbed and at/or within 0.2m below finished grade or the OLS provide a written undertaking to locate buried property bars for all lots within the new subdivisions at no cost to the home owner
- Foundation control certificate has been received
- All mud tracking issues are addressed
- An approved "As-Constructed" site grading plan has been received, reviewed and approved by the Town

- Surveyors Real Property Report, (Building Location Survey, B.L.S.) has been completed by an OLS and a copy submitted to the Town Building Division for review
- Damage to municipal infrastructure has been rectified (if applicable)

The municipal infrastructure deposit, or any portion of, is refundable when the deficiencies have been corrected and given final approval from the Town. All deficiencies shall be corrected within one year from the date of occupancy.

The municipal infrastructure deposit, or any portion remaining after all the above-mentioned issues have been satisfied shall be refunded to the builder upon request. Portions of the deposit not claimed after all issues have been satisfied, after one year, shall be forfeited to the Town.

In the event a municipal infrastructure deposit must be used to correct any of the above items and the actual costs exceed the deposited amount, then the builder will be invoiced the difference.



Section 14 - Appendix "14-1"
Foundation Control Certificate

FOUNDATION CONTROL CERTIFICATE

Town of Tillsonburg

Date: _____

Subdivision Name (if applicable): _____

Civic Address _____

Lot #: _____

Developer: _____

Builder: _____

Date Surveyed: _____

10 Lisgar Ave
Tillsonburg, ON
N4G 5A5

This letter will certify that the top of foundation wall and garage sill have been checked by the undersigned and found to be in general conformity with the approved lot grading plan within the 0.1m tolerance.

This letter will further confirm that the foundation location including all setback distances (front, rear, and sides, as well as lot coverage), have been verified and are in our opinion in compliance with the Municipality's applicable by-laws.

This foundation control certificate in no way relieves the builder/developer from other requirements of the Town of Tillsonburg Design Criteria By-Law in obtaining an approved Final Grading Certificate

- Property Sodded
- Property not yet Sodded

Yours truly,

cc:



Section 14 - Appendix "14-2"
Final Grading Certificate

FINAL LOT GRADING CERTIFICATE

Town of Tillsonburg

Date: _____

Subdivision Name (if applicable): _____

Civic Address _____

Lot #: _____

Developer: _____

Builder: _____

Date Surveyed: _____

To: Chief Building Official
10 Lisgar Ave
Tillsonburg, ON
N4G 5A5

This letter will certify that the lot grading has been checked by the undersigned and found to be in general conformity with the approved lot grading plan within the specified 0.10m tolerance. A stamped copy of the as-constructed plan showing both proposed and finished elevations is attached.

- Property Sodded
- Property not yet Sodded

Yours truly,

cc:



Section 15

Table of Contents

15	PARKLAND AND STREETSCAPING	1
15.1	General Requirements	1
15.2	Parkland Requirements.....	1
15.3	Grading Plans	1
15.4	Grading.....	1
15.5	Servicing.....	2
15.6	Access Walkway	2
15.7	Fencing.....	3
15.8	Seeding	3
15.9	Sod.....	4
15.10	Tree Preservation	4
15.10.1	Prior to Construction.....	4
15.10.2	Tree Protection Zones	4
15.11	Tree Planting / Street Trees	5
15.11.1	Streetscaping Plan	5
15.11.2	Tree Species	5
15.12	Facilities.....	5
15.13	Warranty.....	5
15.14	Trash Receptacle.....	5
15.15	Bollard Lights	6
15.16	Park Benches	6

List of Tables

Table 1. Grading Standards

Table 2: Fencing Requirements

Table 3. Tree Protection Zones

15 PARKLAND AND STREETSCAPING

15.1 General Requirements

This section outlines the recommended approach and design considerations for parklands, streetscaping and access paths as part of developments within the Town of Tillsonburg.

It is the preference of the Town and advantageous to all parties that parklands be constructed to an end use condition less Town installed facilities once phase one of the development reaches 35% completion.

15.2 Parkland Requirements

Consultation with the Town to develop the layout of parkland should be expected. The Town reserves the right to require additional conditions depending on residential density and location within the Town prior to design. This may include, but is not limited to, play equipment, trails, pedestrian cross overs, lighting, landscaping, park furnishings and tree plantings.

It is recommended that developers initiate dialogue with all parties regarding parkland designs and requirements as soon as practically feasible.

15.3 Grading Plans

For all lands dedicated for park purposes the developer is responsible for preparing a detailed grading plan that meets all applicable requirements of Section 14 – Lot Grading, unless amended within this section.

Grading within the parkland or woodland parks are to be optimized for public use subject to review on a case by case basis. Grading of parks and open spaces adjacent to natural heritage areas shall be delineated by appropriate erosion & sediment control fencing as per Section 14 and/or as directed by a site-specific Environmental Impact Study (EIS).

15.4 Grading

Park grading shall provide positive flow from all facilities and adjacent private lands. Limited drainage from private lands may be directed to parkland if it can be accommodated within the park drainage design. Parkland grading and alteration shall be identified in the subdivision grading plan where applicable.

Pathways shall generally be set as high points through the park with positive drainage away from them. Limited amounts of sheet flow may be permitted to cross pathways in certain circumstances in consultation with the Town.

Park grading shall be smooth flowing and shown with spot elevations as required to demonstrate desired slopes, top-of-bank, field corners, and hard surface grades. Swales are to curve to suit facility layout, pathway alignments and natural topographical features.

Sidewalks and hard surface pathways shall be designed for accessibility in accordance with Accessibility for Ontarians with Disabilities Act (AODA) requirements wherever possible.

Refer to Table 1 for specific grading standards.

Table 1. Grading Standards

Surface	Grading Requirements
Sports fields	<ul style="list-style-type: none"> • 1.0% • Directed based on field/site conditions
Asphalt pathways	<ul style="list-style-type: none"> • Less than 8.0% linear slope • 1.0% to 2.0% cross slope
Concrete surfaces	<ul style="list-style-type: none"> • 1.0% to 2.0% cross slope
Woodchip and gravel trails	<ul style="list-style-type: none"> • 2.0% to 3.0% cross slope • Less than 8.0% linear slope is preferred • 15.0% maximum linear slope
Swales	<ul style="list-style-type: none"> • 2.0% to 4.0% for a maximum of 150 m
Embankments	<ul style="list-style-type: none"> • 3:1 maximum slope with undulating surfaces • 2:1 is permitted if area is to be naturalized

Retaining walls are discouraged within a park block unless they are required to maintain existing grades of adjacent facilities or for the protection of significant vegetation.

15.5 Servicing

Water and sewer services are to be designed and constructed within the plan of subdivision to provide service connections to parkland along street frontage as directed by the Town.

15.6 Access Walkway

Access walkways shall be provided where requested by the Town for reasons of, but not limited to, pedestrian connectivity, sewers, drainage, and watermain looping.

Access walkways shall be conforming to the Accessibility for Ontarians with Disabilities Act (AODA) requirements. All walkways shall be 3.0m wide and the full width shall be hard surface, to be determined by Town staff. Grassed paths are not permitted unless directly requested by the Town.

Access walkways may be dual purposed as an emergency access as required by the Town

15.7 Fencing

Fencing is required between parklands and privately owned property and shall be located entirely 0.15m on the Town’s property. Fencing shall not be located adjacent to a public right-of-way, School Block, or any other Town facility, except where fencing is required as directed by the Town. Exceptions will be made at the Town’s discretion when fencing is an integral part of a recreational facility (i.e. baseball diamonds).

No gate shall be installed between private property and parklands.

Fencing, including all hardware and end posts, shall be heavy duty commercial grade and shall be installed by the developer unless otherwise directed by the Town. For new subdivisions, fencing shall be installed within one year of registration and in accordance with the approved engineering plans.

All fencing material shall have a diagonal mesh length of not greater than 38mm and shall consist of 12-gauge galvanized steel wire. The height of the fencing shall be as per Table 2 below

Gates (if required in consultation with the Town) shall be supplied by the developer.

Table 2. Fencing Requirements

Location	Fencing Height Requirements
Perimeter	1.8m
Access Walkway	1.52m

Other materials for fencing may be requested.

15.8 Seeding

Topsoil shall be of the best quality fertile, loose, loamy material screened to be free from stones and weeds, to be placed and graded in the locations and to a minimum depth of 150mm as directed by the Town. Topsoil must not contain any chemical contamination or material detrimental to plant growth.

The primary seed mixture is to have the following composition:

- 30% Canada or Kentucky Blue Grass
- 40% Creeping Red Fescue
- 30% Perennial Rye Grass

Bags are to bear the seed supplier’s label clearly indicating species’ content, grade and mass as well as the recommended seeding rate for the establishment of new lawn areas. If seeded, the application method shall be hydroseeding or another method approved by the Town.

15.9 Sod

Sod is to be No. 1 Nursery Grade Kentucky Bluegrass Nursery Sod according to the Specifications, Classifications and Use of Turfgrass Sod for Nursery Sod Growers Association of Ontario.

Sod is to be seeded and established in nursery sod fields as a turfgrass sod. There shall be no more than 5 broadleaf weeds per 40 square metres of sod and up to 20% non-specified grass. Sod shall be of sufficient density that no surface soil is visible. The grass height is to be between 30mm minimum and 70mm maximum.

15.10 Tree Preservation

Prior to any grading or construction, it is important to evaluate existing trees to retain as many as possible. It is required that a certified arborist, Registered Professional Forester or other qualified person with appropriate training and experience be employed by the Developer to carry out such evaluations on both private and public lands.

15.10.1 Prior to Construction

In areas of reconstruction or within infrastructure renewal projects, tree protection measures must be considered to limit the health impacts on trees within the public rights-of-way and adjacent properties.

15.10.2 Tree Protection Zones

A tree protection zone (TPZ) is the calculated area around the base of a tree that is designated for tree protection both above and below ground. Caution and alternative construction methods (such as air chisel/spade, vacuum excavation, root pruning, etc.) are encouraged to limit the damage to public trees.

Tree protection fencing/barriers should be placed on the perimeter of the TPZ wherever possible.

General TPZ guidelines are shown in the Table 3.

Table 3. Tree Protection Zones

Minimum Protection Distances Required Town-owned Trees	Minimum Protection Distances Required For areas designated Open Space, Parkland or Woodlands
6.0 times the Trunk Diameter at Breast Height (1.4m)	12.0 times the Trunk Diameter at Breast Height (1.4m)

Should construction activities be considered within calculated TPZs, a certified arborist should be retained to comment on the health impacts and provide recommendations for preservation and/or removal.

15.11 Tree Planting / Street Trees

Right of way street trees are to be required for each lot and or unit and location based on Town of Tillsonburg Standard drawings.

Private tree plantings are to be a minimum of 3m from the property line in all cases.

15.11.1 Streetscaping Plan

The developer is to submit a Tree Planting Plan for streetscaping or parklands if requested by the Town, prepared by a Landscape Architect as part of the first engineering submission. The plan shall list in table format, the selected species by common and cultivar name, size, planting state and include in the notes all required specifications.

Consideration shall be given to avoid utility and underground infrastructure conflicts in all Tree Planting Plans within the municipal right-of-way.

15.11.2 Tree Species

Tree species shall be selected by a qualified professional and must be approved by the Town prior to planting. The tree species are to follow the Town of Tillsonburg Tree By-law.

The planting plan shall consider species diversity.

The trees must be 50mm caliper or larger with a single trunk.

Native tree species are preferred, especially near natural areas. No invasive or non-native tree species are to be planted within 250m of a natural area.

All trees must be of No. 1 Grade.

15.12 Facilities

Park facilities are not generally installed by a developer as part of park development however the developer is to obtain a landscape architect when required by the Town. Occasionally, developers may proceed with a certain level of facility development to provide an amenity within their subdivision, subject to the discretion and approval of the Town.

15.13 Warranty

A one year warranty is to be provided for all plantings within the park.

15.14 Trash Receptacle

Trash receptacles shall follow the below design criteria

- Model LR305R by Wabash Valley – or approved equivalent
- 32 gallon
- Rib pattern

- Platisol finish in black
- With side door
- Including bin liner and dome top lid in black
- Surface mount on 1.0m x 1.0m concrete pad per manufacturer's specifications

15.15 Bollard Lights

Bollard Lights shall follow the below design criteria

- Solar powered LED
- Model WLB-102 by Firstlight Technologies or approved equivalent
- Install per manufacturers specifications on concrete footing 600mm from edge of path

15.16 Park Benches

New parkland developments shall include a minimum of four (4) park benches per acre supplied and installed by the Developer. The locations of the benches shall be in close proximity to hard surface pathways.

- The benches shall be Model CY420R by Wabash Valley or approved equivalent
- Length 6'-0"
- Rib pattern
- Platisol finish in black
- Surface mount concrete pad per manufacturer's specifications

Appendix “A”
Town of Tillsonburg Standard Drawings

TOWN OF TILLSONBURG STANDARD DETAILS

Table of Contents

0200 SUBDIVISION

Unassumed Road Signs	TSD-220
Typical Title Pages	TSD-221
General Notes	TSD-222
Typical Project Identification Sign	TSD-223

0300 SUBDIVISION

Standard Residential Service Locations 10.5m Lot	TSD-300
Standard Residential Service Locations 12.5m Lot	TSD-301
Standard Residential Service Locations 15.0m Lot	TSD-302
Standard Townhouse Service Locations 32.0m Lot	TSD-303
Standard Townhouse Service Locations 32.0m Lot	TSD-304
Private Drain Connections	TSD-310
Typical Sanitary Cleanout	TSD-311
Foundation Drain Outlet – Sump Pump to Storm Sewer	TSD-312
Foundation Drain Outlet – Sump Pump to Surface	TSD-313

0400 SITE PLAN

Standard Industrial/Commercial Service Locations	TSD-400
--	---------

0600 SITE GENERAL

Construction Entrance Mat	TSD-600
Topsoil or Soil Pile Siltation Control	TSD-601

0700 ROADWAYS

18.0m Local Road Allowance – 8.0m Asphalt	TSD-700
20.0m Local Road Allowance – 8.0m Asphalt	TSD-701
22.0m Collector Road Allowance (Bike Lanes) – 10.0m Asphalt	TSD-702
22.0m Collector Road Allowance (Turn Lane) – 10.0m Asphalt	TSD-703
22.0m Collector Road Allowance (Median) – 10.0m Asphalt	TSD-704

26.0m Arterial Road Allowance - 14.0m Asphalt	TSD-705
26.0m Arterial Road Allowance (Parking) – 14.0m Asphalt	TSD-706
26.0m Arterial Road Allowance (Bike Lanes) – 14.0m Asphalt	TSD-707
Typical 100mm Subdrain Detail	TSD-710
Driveway and Entrance Detail	TSD-711
Boulevard Pathway	TSD-712
Pipe Bollard	TSD-713
Typical Daylighting Requirements	TSD-720
Typical Intersection Semi-Urban – 18.0m Radius 26.0m R.O.W.	TSD-721
Roundabout – Single Lane	TSD-722
Sidewalk Ramps, Bike Lanes, Crosswalks at Roundabouts	TSD-723
Temporary Residential Cul-de-sac	TSD-730
Typical Trench Restoration	TSD-740
General Notes for Roadworks	TSD-750

1000 STORM SEWERS

Maintenance Hole and Catch Basin Adjustment Units	TSD-1010
---	----------

1100 STORMWATER MANAGEMENT

Outlet Structure Typical Detail Wet Pond Facility with Maintenance Pipe	TSD-1100
Outlet Structure Typical Detail Wetland Facility without Maintenance Pipe	TSD-1101
Temporary Outlet Structure Typical Detail	TSD-1102
SWM Facility Grading and Water Level Criteria	TSD-1103
Outlet Erosion Protection Typical Detail	TSD-1104
Forebay Hickenbottom Detail	TSD-1105
Stormwater Planting Zone Composition	TSD-1106

1200 SANITARY SEWERS

PVC Inside Drop Sewer Service Connection	TSD-1200
PVC Inside Drop Sewer Maintenance Hole	TSD-1201

1300 WATERMANS

General Notes Watermain	TSD-1300
Tracer Wire Detail	TSD-1301
Typical Cul-de-sac Watermain Design (50mm Dia. Loop)	TSD-1306
Hydrant Platform Detail	TSD-1331

Temporary Riser Installation	TSD-1340
Valve Stem Extension in Valve Box	TSD-1350
50mm Blow Off Detail	TSD-1360
Watermain Lowering Detail for Storm Sewer or Ditch Crossing	TSD-1366
Support for Watermains Larger than 300mm Dia.	TSD-1367
Watermain Rail Crossing Detail	TSD-1368

1400 LOT GRADING

Rear to Front Yard Drainage	TSD-1400
Shared Storm Easement	TSD-1401
Rear Yard Catchbasin	TSD-1402
Upper to Lower Lot Drainage	TSD-1403
Typical Side Yard Drainage	TSD-1404



NOTES:

1. COLOUR OF LETTERING TO BE BLACK, BACKGROUND YELLOW.
2. ALL DIMENSIONS ARE IN MILLIMETERS UNLESS OTHERWISE SHOWN.



STANDARD DETAIL

UNASSUMED ROAD SIGN

APPROVED

.....
MANAGER OF ENGINEERING DATE

.....
DIRECTOR OF OPERATIONS DATE

REVISION No. DATE: MARCH 2020

SCALE: N.T.S.

TSD-220

SUBDIVISION NAME

SUBDIVISION TYPE

BLOCK #

PLAN

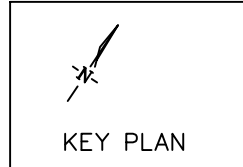

1

2

3



ABC ROAD SURFACE IMPROVEMENTS

CONTRACT # 20xx-xx



LIST OF DRAWINGS

- SAN1 - SANITARY DRAINAGE PLAN
- STM1 - STORM DRAINAGE PLAN
- PP1 - ABC ROAD STA. (AT)
- PP2 - ABC ROAD STA. (AT)
- PP3 - ABC ROAD STA. (AT)
- PP4 - ABC ROAD STA. (AT)
- DET1 - GENERAL NOTES & DETAILS
- DET2 - PAVEMENT MARKINGS
- DET3 - TYPICAL SECTIONS
- DET4 - DETAILS
- DET5 - OPSD DETAILS
- DET6 - WATERMAIN DETAILS

- 1 TOWN OF TILSONBURG, ENGINEERING DEPARTMENT, TILSONBURG, ONTARIO
- 2 DEVELOPER'S NAME & ADDRESS
- 3 DEVELOPER'S ENGINEER & ADDRESS



STANDARD DETAIL

TYPICAL TITLE PAGES

APPROVED

.....
MANAGER OF ENGINEERING DATE
.....
DIRECTOR OF OPERATIONS DATE

REVISION No. DATE: DEC 2021
SCALE: N.T.S.

TSD-221

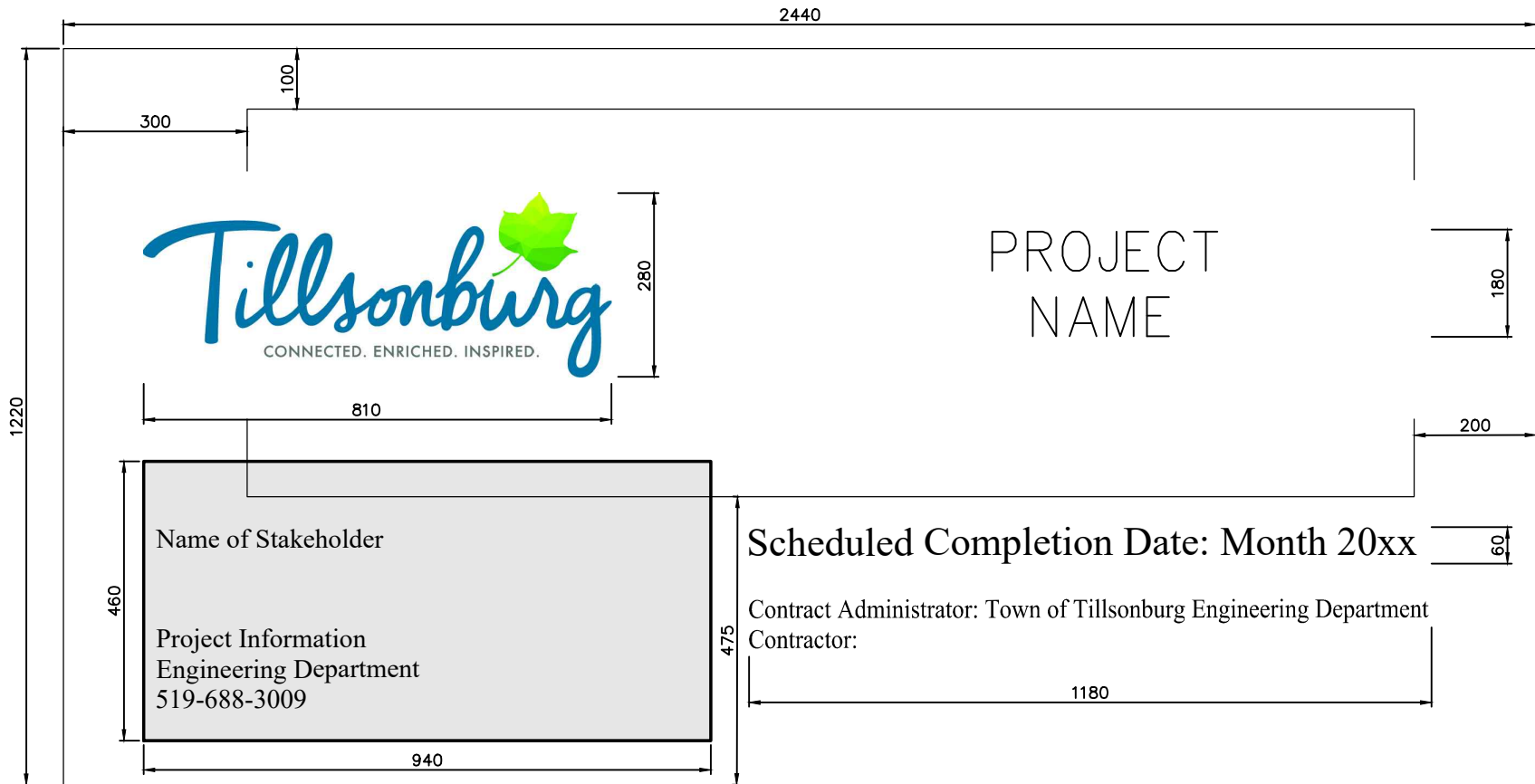

NOTES:

1. CONTACT THE TOWN OF TILLSONBURG ENGINEERING DEPARTMENT FOR EXACT COLOURS AND INFORMATION DETAILS.
2. ALL DIMENSIONS ARE IN MILLIMETRES UNLESS OTHERWISE SHOWN.



STANDARD DETAIL

TYPICAL PROJECT IDENTIFICATION SIGN

APPROVED

MANAGER OF ENGINEERING DATE
 DIRECTOR OF OPERATIONS DATE

REVISION No. DATE: MARCH 2020
 SCALE: N.T.S.

TSD-223

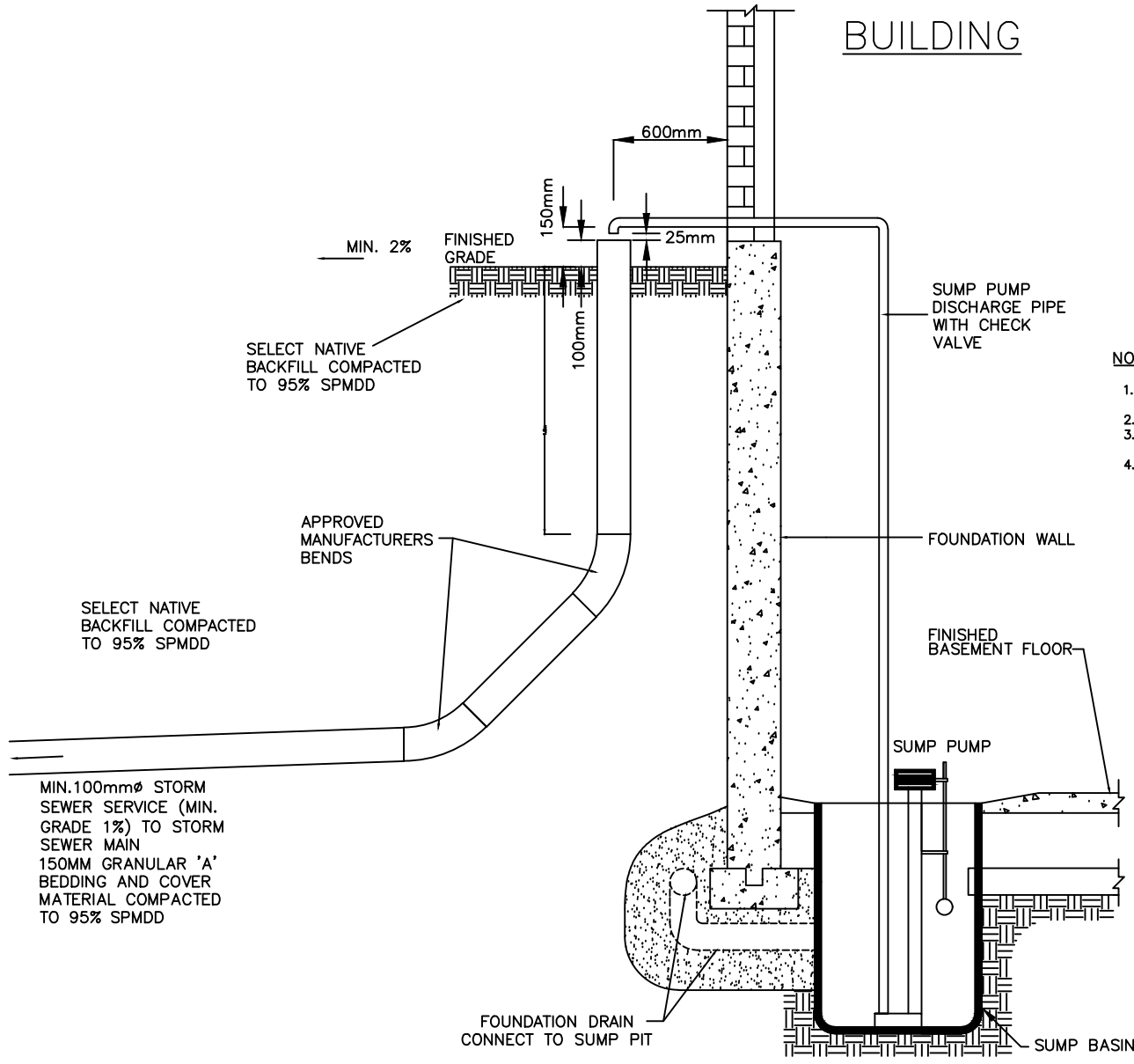

- NOTES:**
1. PIPE SHALL BE 100mm DIA. PVC. MEETING CSA-B182.4-M90, RUBBER GASKET TYPE JOINTS OR EQUIVALENT.
 2. MIN. SLOPE OF PIPE TO BE 1%.
 3. JUNCTION OF SUMP DISCHARGE AND STORM SERVICE MUST BE ABOVE FINISHED GRADE AND IS NOT TO BE SEALED.
 4. ALL PLUMBING TO CONFORM TO ONTARIO BUILDING CODE.



FOUNDATION DRAIN OUTLET SUMP PUMP TO STORM SEWER AT SURFACE

APPROVED

MANAGER OF ENGINEERING DATE
DIRECTOR OF OPERATIONS DATE

REVISION No. DATE: DEC 2021
SCALE: N.T.S.

TSD-230

STANDARD DETAIL

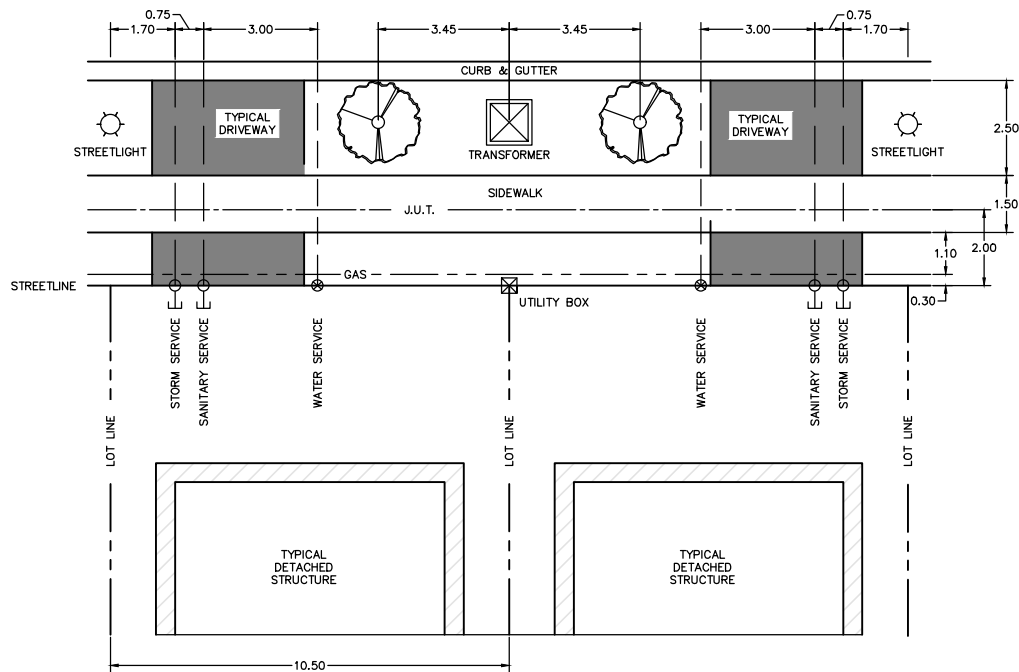

NOTES:

1. FOR WATER AND SANITARY SERVICE SPECIFICATIONS, REFER TO OXFORD COUNTY DESIGN GUIDELINES AND SPECIFICATIONS.
2. FOR STORMWATER SERVICE SPECIFICATIONS REFER TO TOWN OF TILLSONBURG DEVELOPMENT GUIDELINES AND DESIGN CRITERIA.
3. SANITARY AND STORMWATER SERVICES ARE TO BE BROUGHT 1.0m PAST PROPERTY LINE AND PROPERLY MARKED WITH A 50x100mm STAKE EXTENDING FROM THE INVERT OF THE SERVICE TO GROUND LEVEL. SANITARY SERVICES TO BE MARKED GREEN. STORM SERVICES TO BE MARKED IN WHITE.
4. WATER SERVICES ARE TO BE BROUGHT TO PROPERTY LINE, TERMINATED WITH A CURB STOP AND PROPERLY MARKED WITH A 50 X 100mm STAKE EXTENDING FROM THE INVERT OF SERVICE TO GROUND LEVEL. WATER SERVICES TO BE MARKED BLUE.
5. ALL DIMENSIONS ARE IN METRES UNLESS OTHERWISE SHOWN.
6. REFER TO TSD-301 FOR VERTICAL LOCATION OF PRIVATE DRAIN CONNECTIONS AT PROPERTY LINES.
7. REFER TO TSD-302 FOR TYPICAL STORMWATER PRIVATE DRAIN CLEAN-OUT DETAIL.
8. REFER TO OXFORD COUNTY D-1860-1-2018 TYPICAL SANITARY PRIVATE DRAIN CLEAN-OUT DETAIL.



STANDARD DETAIL

STANDARD RESIDENTIAL SERVICE LOCATIONS 10.5m LOT

APPROVED

MANAGER OF ENGINEERING DATE

DIRECTOR OF OPERATIONS DATE

REVISION No. DATE: FEB 2022

SCALE: N.T.S.

TSD-300

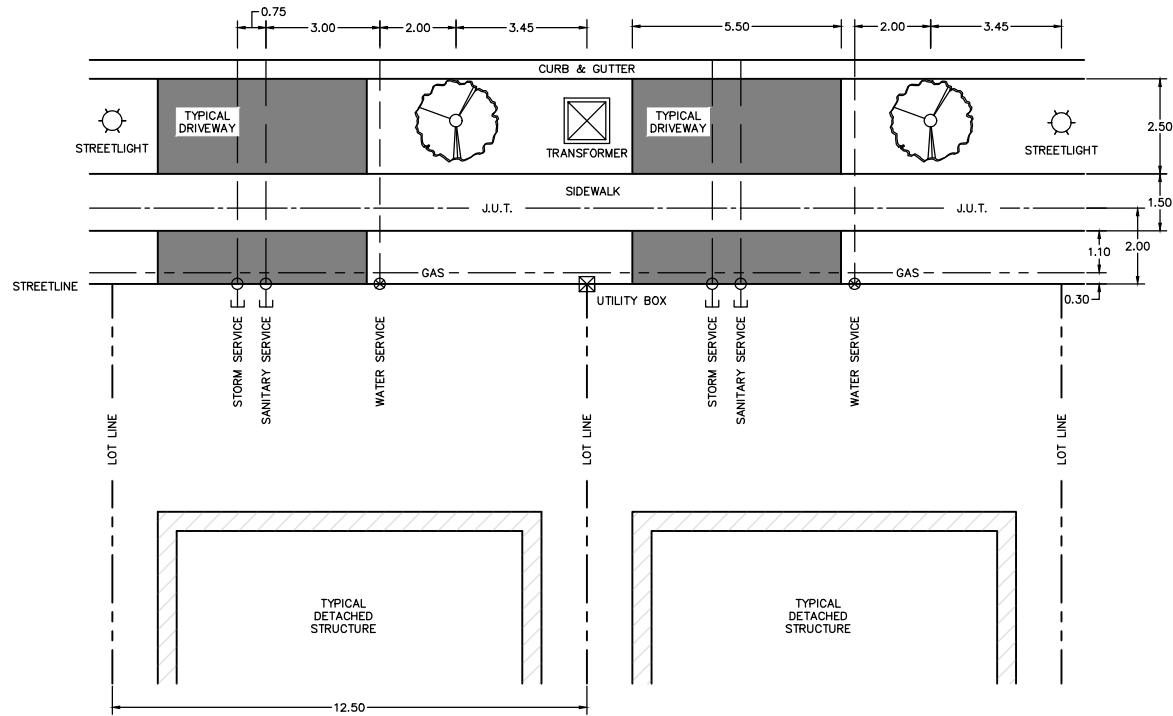

NOTES:

- FOR WATER AND SANITARY SERVICE SPECIFICATIONS, REFER TO OXFORD COUNTY DESIGN GUIDELINES AND SPECIFICATIONS.
- FOR STORMWATER SERVICE SPECIFICATIONS REFER TO TOWN OF TILLSONBURG DEVELOPMENT GUIDELINES AND DESIGN CRITERIA.
- SANITARY AND STORMWATER SERVICES ARE TO BE BROUGHT 1.0m PAST PROPERTY LINE AND PROPERLY MARKED WITH A 50x100mm STAKE EXTENDING FROM THE INVERT OF THE SERVICE TO GROUND LEVEL. SANITARY SERVICES TO BE MARKED GREEN. STORM SERVICES TO BE MARKED IN WHITE.
- WATER SERVICES ARE TO BE BROUGHT TO PROPERTY LINE, TERMINATED WITH A CURB STOP AND PROPERLY MARKED WITH A 50 X 100mm STAKE EXTENDING FROM THE INVERT OF SERVICE TO GROUND LEVEL. WATER SERVICES TO BE MARKED BLUE.
- ALL DIMENSIONS ARE IN METRES UNLESS OTHERWISE SHOWN.
- REFER TO TSD-301 FOR VERTICAL LOCATION OF PRIVATE DRAIN CONNECTIONS AT PROPERTY LINES.
- REFER TO TSD-302 FOR TYPICAL STORMWATER PRIVATE DRAIN CLEAN-OUT DETAIL.
- REFER TO OXFORD COUNTY D-1860-1-2018 TYPICAL SANITARY PRIVATE DRAIN CLEAN-OUT DETAIL.



STANDARD DETAIL

STANDARD RESIDENTIAL
SERVICE LOCATIONS
12.5m LOT

APPROVED

MANAGER OF ENGINEERING DATE
DIRECTOR OF OPERATIONS DATE

REVISION No. DATE: FEB 2022
SCALE: N.T.S.

TSD-301

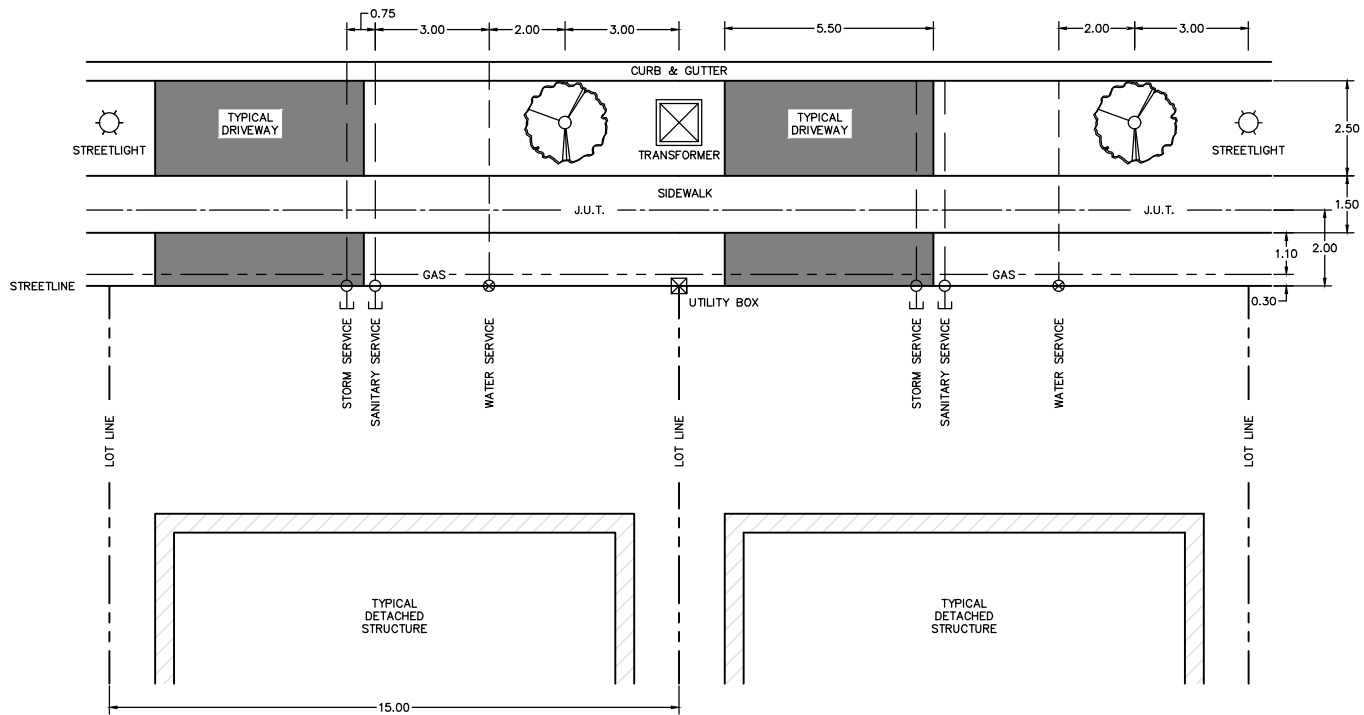

NOTES:

1. FOR WATER AND SANITARY SERVICE SPECIFICATIONS, REFER TO OXFORD COUNTY DESIGN GUIDELINES AND SPECIFICATIONS.
2. FOR STORMWATER SERVICE SPECIFICATIONS REFER TO TOWN OF TILLSONBURG DEVELOPMENT GUIDELINES AND DESIGN CRITERIA.
3. SANITARY AND STORMWATER SERVICES ARE TO BE BROUGHT 1.0m PAST PROPERTY LINE AND PROPERLY MARKED WITH A 50x100mm STAKE EXTENDING FROM THE INVERT OF THE SERVICE TO GROUND LEVEL. SANITARY SERVICES TO BE MARKED GREEN. STORM SERVICES TO BE MARKED IN WHITE.
4. WATER SERVICES ARE TO BE BROUGHT TO PROPERTY LINE, TERMINATED WITH A CURB STOP AND PROPERLY MARKED WITH A 50 X 100mm STAKE EXTENDING FROM THE INVERT OF SERVICE TO GROUND LEVEL. WATER SERVICES TO BE MARKED BLUE.
5. ALL DIMENSIONS ARE IN METRES UNLESS OTHERWISE SHOWN.
6. REFER TO TSD-301 FOR VERTICAL LOCATION OF PRIVATE DRAIN CONNECTIONS AT PROPERTY LINES.
7. REFER TO TSD-302 FOR TYPICAL STORMWATER PRIVATE DRAIN CLEAN-OUT DETAIL.
8. REFER TO OXFORD COUNTY D-1860-1-2018 TYPICAL SANITARY PRIVATE DRAIN CLEAN-OUT DETAIL.



STANDARD DETAIL

STANDARD RESIDENTIAL SERVICE LOCATIONS 15m LOT

APPROVED

MANAGER OF ENGINEERING DATE

DIRECTOR OF OPERATIONS DATE

REVISION No. DATE: FEB 2022

SCALE: N.T.S.

TSD-302

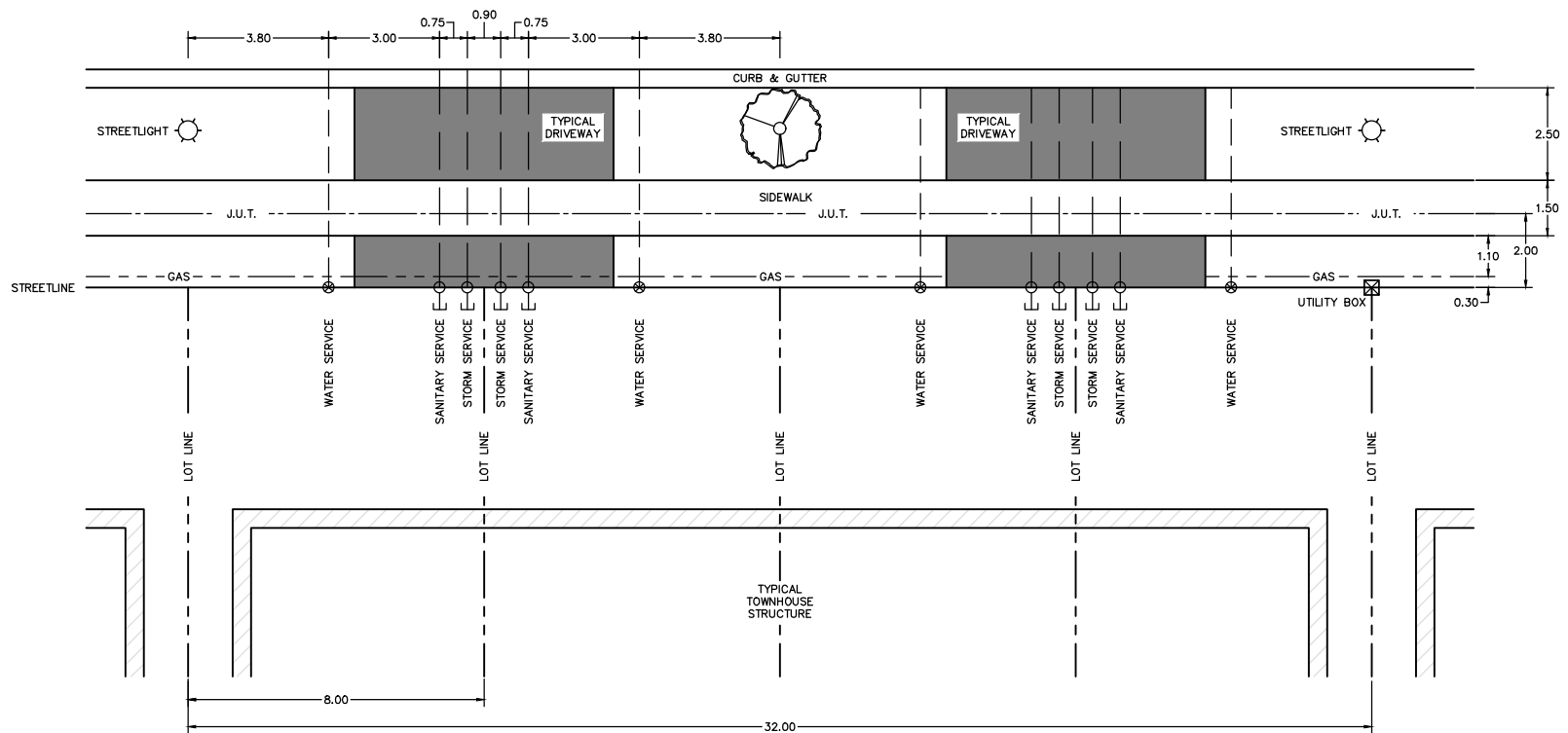

NOTES:

- FOR WATER AND SANITARY SERVICE SPECIFICATIONS, REFER TO OXFORD COUNTY DESIGN GUIDELINES AND SPECIFICATIONS.
- FOR STORMWATER SERVICE SPECIFICATIONS REFER TO TOWN OF TILLSONBURG DEVELOPMENT GUIDELINES AND DESIGN CRITERIA.
- SANITARY AND STORMWATER SERVICES ARE TO BE BROUGHT 1.0m PAST PROPERTY LINE AND PROPERLY MARKED WITH A 50x100mm STAKE EXTENDING FROM THE INVERT OF THE SERVICE TO GROUND LEVEL. SANITARY SERVICES TO BE MARKED GREEN. STORM SERVICES TO BE MARKED IN WHITE.
- WATER SERVICES ARE TO BE BROUGHT TO PROPERTY LINE, TERMINATED WITH A CURB STOP AND PROPERLY MARKED WITH A 50 X 100mm STAKE EXTENDING FROM THE INVERT OF SERVICE TO GROUND LEVEL. WATER SERVICES TO BE MARKED BLUE.
- ALL DIMENSIONS ARE IN METRES UNLESS OTHERWISE SHOWN.
- REFER TO TSD-301 FOR VERTICAL LOCATION OF PRIVATE DRAIN CONNECTIONS AT PROPERTY LINES.
- REFER TO TSD-302 FOR TYPICAL STORMWATER PRIVATE DRAIN CLEAN-OUT DETAIL.
- REFER TO OXFORD COUNTY D-1860-1-2018 TYPICAL SANITARY PRIVATE DRAIN CLEAN-OUT DETAIL.



STANDARD DETAIL

STANDARD TOWNHOUSE SERVICE LOCATIONS 32m LOT

APPROVED

MANAGER OF ENGINEERING DATE

DIRECTOR OF OPERATIONS DATE

REVISION No. DATE: FEB 2022

SCALE: N.T.S.

TSD-303

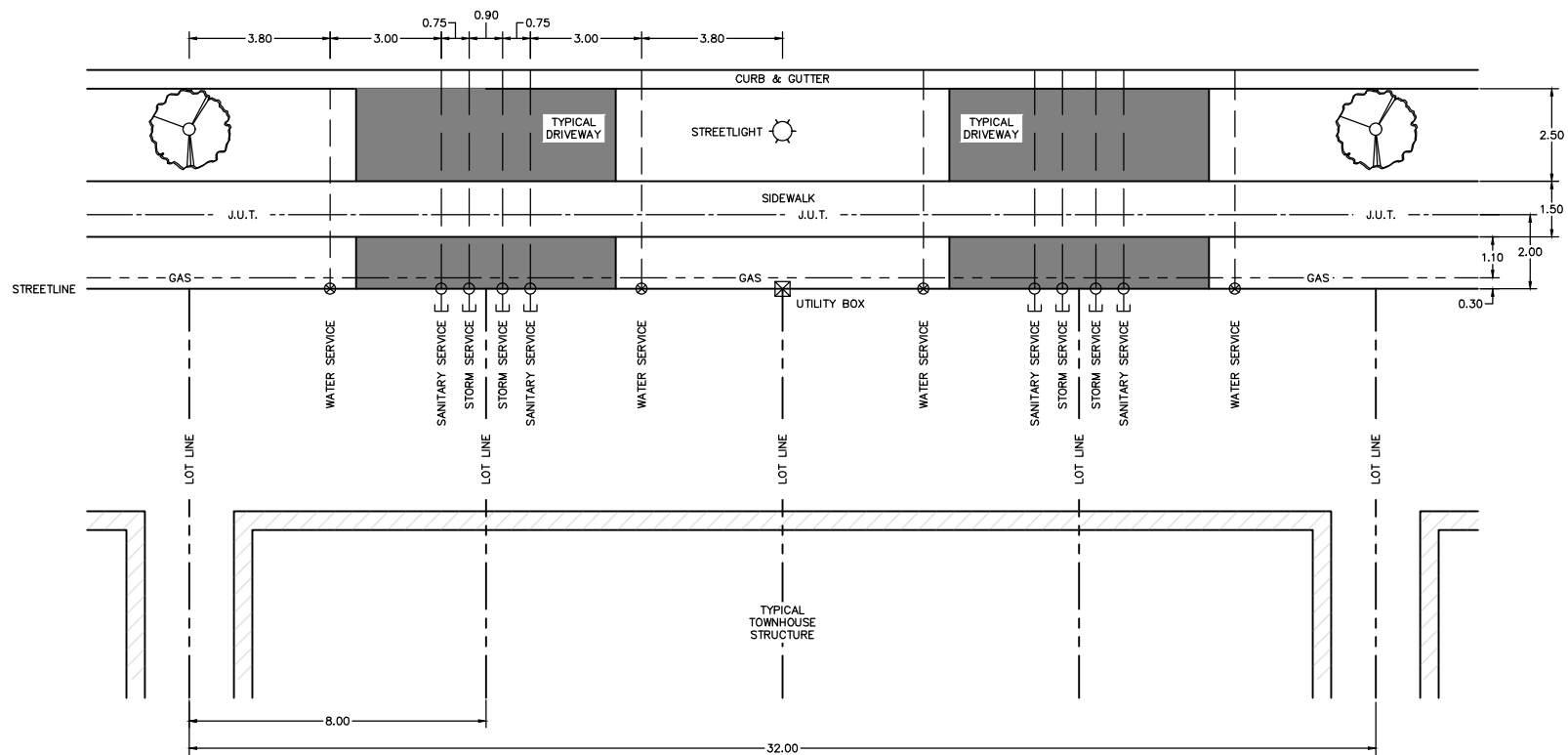

NOTES:

1. FOR WATER AND SANITARY SERVICE SPECIFICATIONS, REFER TO OXFORD COUNTY DESIGN GUIDELINES AND SPECIFICATIONS.
2. FOR STORMWATER SERVICE SPECIFICATIONS REFER TO TOWN OF TILLSONBURG DEVELOPMENT GUIDELINES AND DESIGN CRITERIA.
3. SANITARY AND STORMWATER SERVICES ARE TO BE BROUGHT 1.0m PAST PROPERTY LINE AND PROPERLY MARKED WITH A 50x100mm STAKE EXTENDING FROM THE INVERT OF THE SERVICE TO GROUND LEVEL. SANITARY SERVICES TO BE MARKED GREEN. STORM SERVICES TO BE MARKED IN WHITE.
4. WATER SERVICES ARE TO BE BROUGHT TO PROPERTY LINE, TERMINATED WITH A CURB STOP AND PROPERLY MARKED WITH A 50 X 100mm STAKE EXTENDING FROM THE INVERT OF SERVICE TO GROUND LEVEL. WATER SERVICES TO BE MARKED BLUE.
5. ALL DIMENSIONS ARE IN METRES UNLESS OTHERWISE SHOWN.
6. REFER TO TSD-301 FOR VERTICAL LOCATION OF PRIVATE DRAIN CONNECTIONS AT PROPERTY LINES.
7. REFER TO TSD-302 FOR TYPICAL STORMWATER PRIVATE DRAIN CLEAN-OUT DETAIL.
8. REFER TO OXFORD COUNTY D-1860-1-2018 TYPICAL SANITARY PRIVATE DRAIN CLEAN-OUT DETAIL.



STANDARD DETAIL

STANDARD TOWNHOUSE SERVICE LOCATIONS 32m LOT

APPROVED

MANAGER OF ENGINEERING DATE
DIRECTOR OF OPERATIONS DATE

REVISION No. DATE: FEB 2022

SCALE: N.T.S.

TSD-304

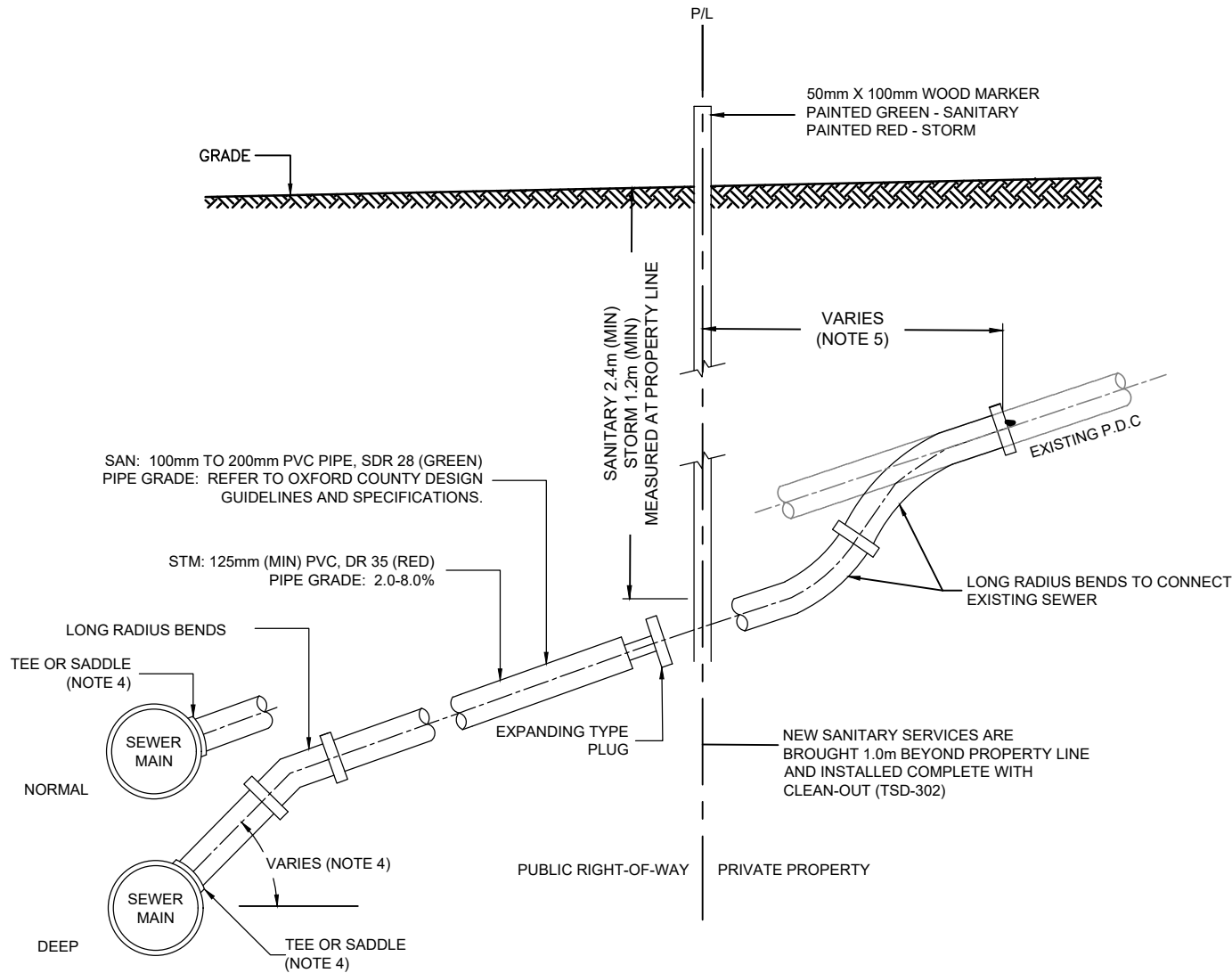

NOTES:

1. FOR SANITARY SERVICE SPECIFICATIONS, REFER TO OXFORD COUNTY DESIGN GUIDELINES AND SPECIFICATIONS.
2. FOR STORMWATER SERVICE SPECIFICATIONS REFER TO TOWN OF TILLSONBURG DEVELOPMENT GUIDELINES AND DESIGN CRITERIA.
3. PDCs TO BE PLACED AT DEPTHS AND LOCATIONS SHOWN UNLESS OTHERWISE DIRECTED BY THE TOWN ENGINEER.
4. A TYPICAL 'NORMAL' FLAT TEE IS PREFERRED. FOR DEEP STORM SEWERS (GREATER THAN 3.5m), A 45° INCLINED TEE MAY BE USED WITH THE APPROVAL OF THE TOWN ENGINEER. FOR DEEP CONNECTIONS TO SANITARY SEWERS GREATER THAN 3.5m IN DEPTH, REFER TO OXFORD COUNTY DESIGN GUIDELINES AND SPECIFICATIONS.
5. PDCs SHALL BE LAID AT DESIGN GRADE TO THE PROPERTY LINE. CONNECTIONS TO EXISTING SEWERS MAY BE MADE BEYOND THIS POINT WITH APPROVED WATERTIGHT FITTINGS USING LONG RADIUS BENDS, CUT AS REQUIRED TO SUIT SITE CONDITIONS. CEMENT MORTAR JOINTS WILL NOT BE ACCEPTED.
6. PDC GRADES MUST BE SELECTED TO AVOID CONFLICTS WITH OTHER EXISTING/PROPOSED INFRASTRUCTURE AND MAINTAIN APPLICABLE SEPARATION REQUIREMENTS.
7. ALL DIMENSIONS ARE IN METRES UNLESS OTHERWISE SHOWN.



STANDARD DETAIL

PRIVATE DRAIN CONNECTIONS

APPROVED

MANAGER OF ENGINEERING DATE
 DIRECTOR OF OPERATIONS DATE

REVISION No. DATE: DEC 2021
 SCALE: N.T.S.

TSD-310

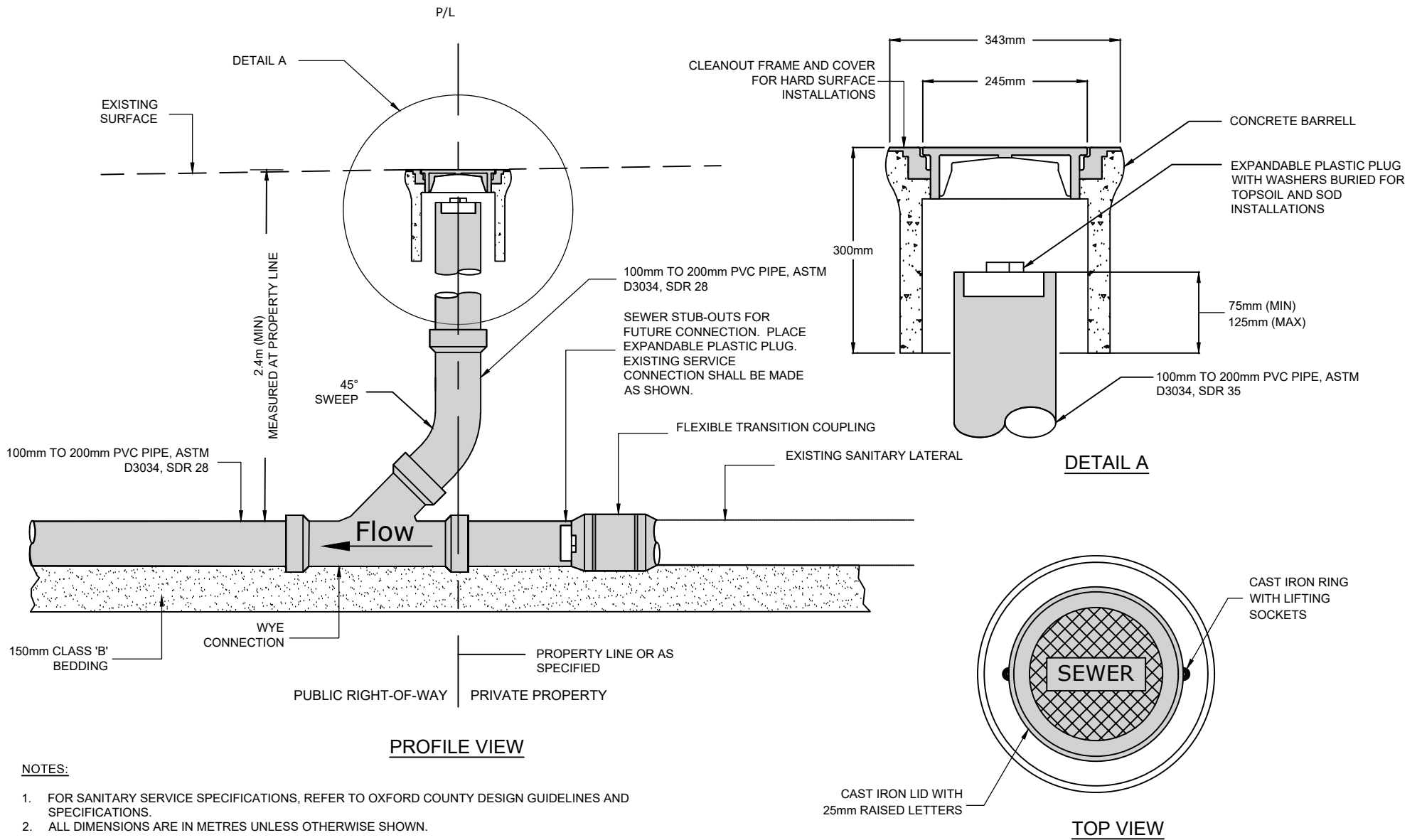

NOTES:

1. FOR SANITARY SERVICE SPECIFICATIONS, REFER TO OXFORD COUNTY DESIGN GUIDELINES AND SPECIFICATIONS.
2. ALL DIMENSIONS ARE IN METRES UNLESS OTHERWISE SHOWN.

TYPICAL SANITARY CLEANOUT

APPROVED

MANAGER OF ENGINEERING DATE
 DIRECTOR OF OPERATIONS DATE

REVISION No. DATE: MARCH 2020
 SCALE: N.T.S.

TSD-311



STANDARD DETAIL

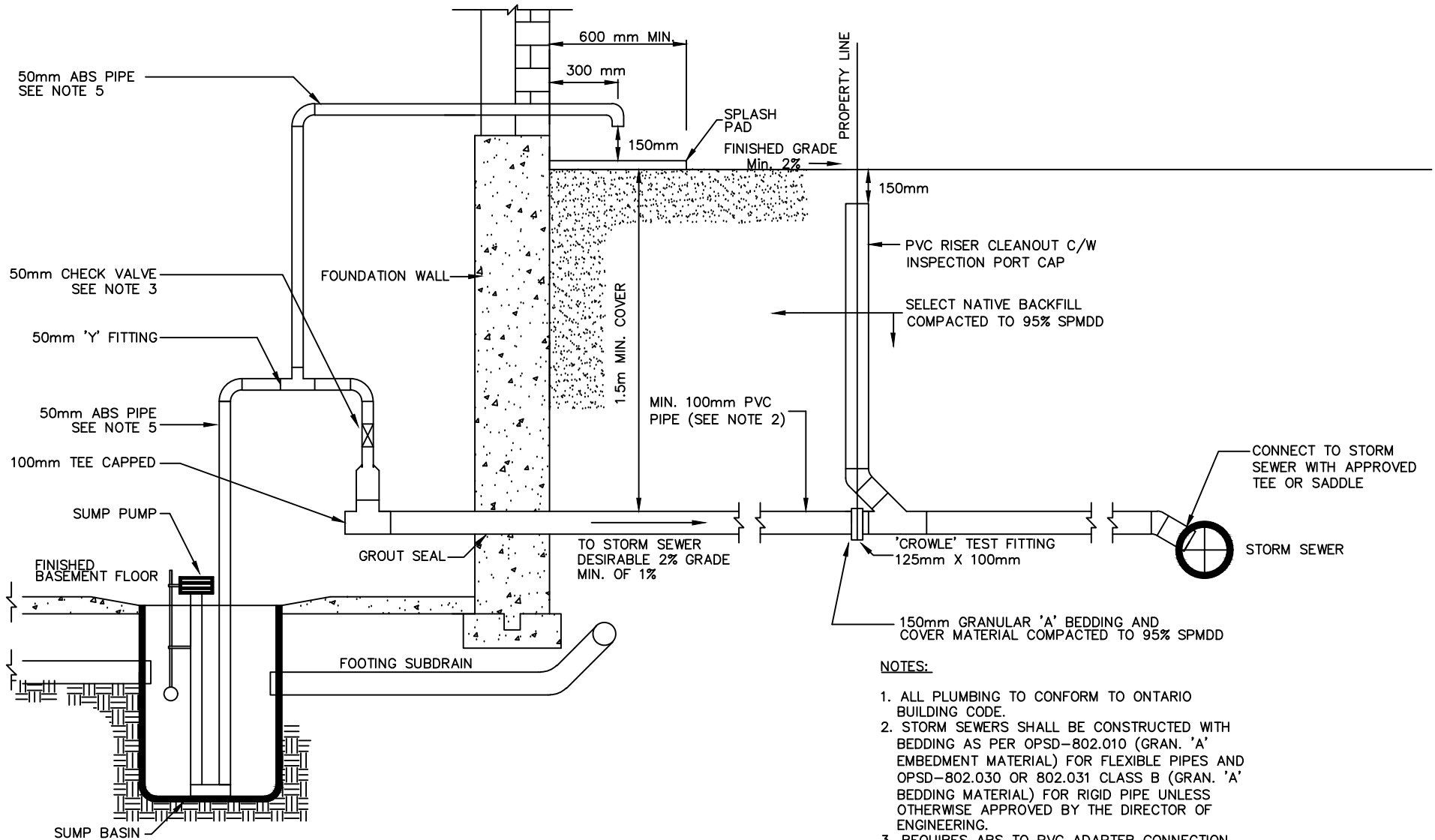

NOTES:

1. ALL PLUMBING TO CONFORM TO ONTARIO BUILDING CODE.
2. STORM SEWERS SHALL BE CONSTRUCTED WITH BEDDING AS PER OPSD-802.010 (GRAN. 'A' EMBEDMENT MATERIAL) FOR FLEXIBLE PIPES AND OPSD-802.030 OR 802.031 CLASS B (GRAN. 'A' BEDDING MATERIAL) FOR RIGID PIPE UNLESS OTHERWISE APPROVED BY THE DIRECTOR OF ENGINEERING.
3. REQUIRES ABS TO PVC ADAPTER CONNECTION.
4. POLYVINYL CHLORIDE SEWER PIPE (PVC) STORM PIPE B182.1 B181.2, B182.4
5. ACRYLONITRILE-BUTADIENE-STYRENE (ABS) PIPE B181.1



STANDARD DETAIL

FOUNDATION DRAIN OUTLET SUMP PUMP TO STORM SEWER

APPROVED

MANAGER OF ENGINEERING DATE

DIRECTOR OF OPERATIONS DATE

REVISION No. DATE: DEC 2021

SCALE: N.T.S.

TSD-312

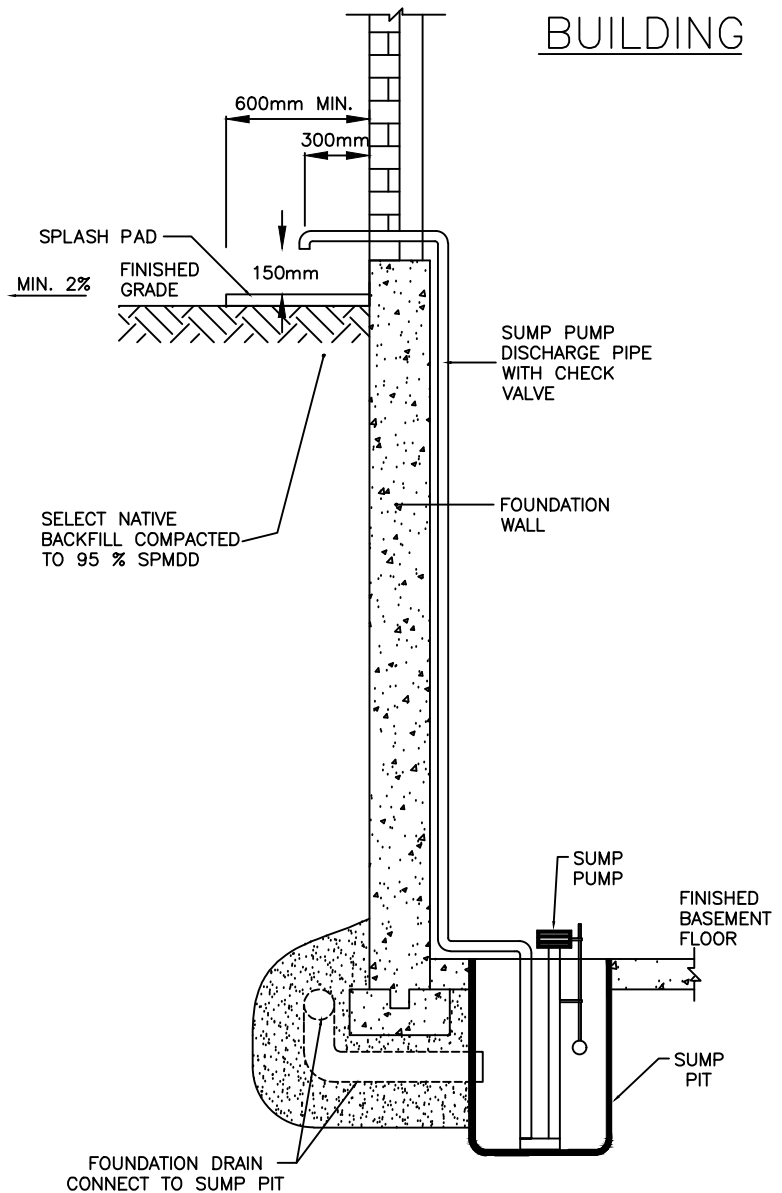

NOTES:
1. ALL PLUMBING TO CONFORM TO ONTARIO BUILDING CODE.



STANDARD DETAIL

FOUNDATION DRAIN OUTLET SUMP PUMP TO SURFACE

APPROVED

MANAGER OF ENGINEERING DATE

DIRECTOR OF OPERATIONS DATE

REVISION No. DATE: DEC 2021

SCALE: N.T.S.

TSD-313

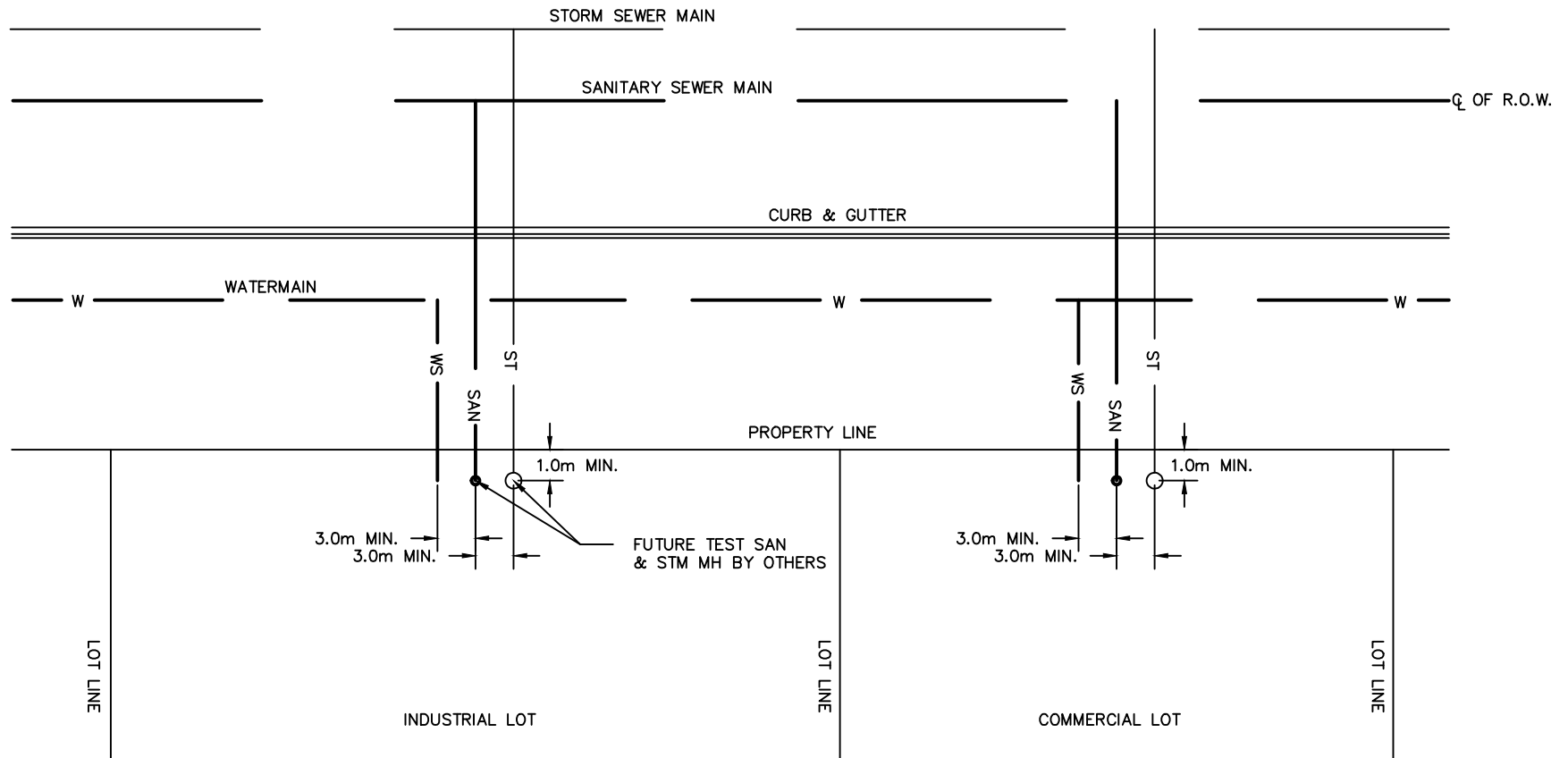

NOTES:

- ALL SERVICES TO BE BROUGHT 1.0m MIN. PAST PROPERTY LINE AND PROPERLY MARKED WITH A 50x100mm STAKE EXTENDING FROM THE INVERT OF THE LATERAL TO GROUND LEVEL.
 MARKINGS AS FOLLOWS :
 SANITARY LATERAL – GREEN
 STORM LATERAL – RED
 WATER LATERAL – BLUE
- SANITARY LATERAL TO BE LOCATED AT THE CENTRE LINE OF EACH UNIT.
- WATER LATERAL TO BE LOCATED 2.5m OFFSET NORTH OR WEST OF THE SANITARY LATERAL.
- STORM LATERAL, IF PROVIDED, TO BE LOCATED 3.0m OFFSET SOUTH OR EAST OF SANITARY LATERAL.
- ALL STORM & SANITARY MAINTENANCE HOLES TO BE OPSD 701.01 – 1200mm DIA.
- ALL DIMENSIONS ARE IN METRES UNLESS OTHERWISE SHOWN.



STANDARD DETAIL

STANDARD
INDUSTRIAL/COMMERCIAL
SERVICE LOCATIONS

APPROVED

.....
MANAGER OF ENGINEERING DATE
.....
DIRECTOR OF OPERATIONS DATE

REVISION No.	DATE: DEC 2021
	SCALE: N.T.S.

TSD-400

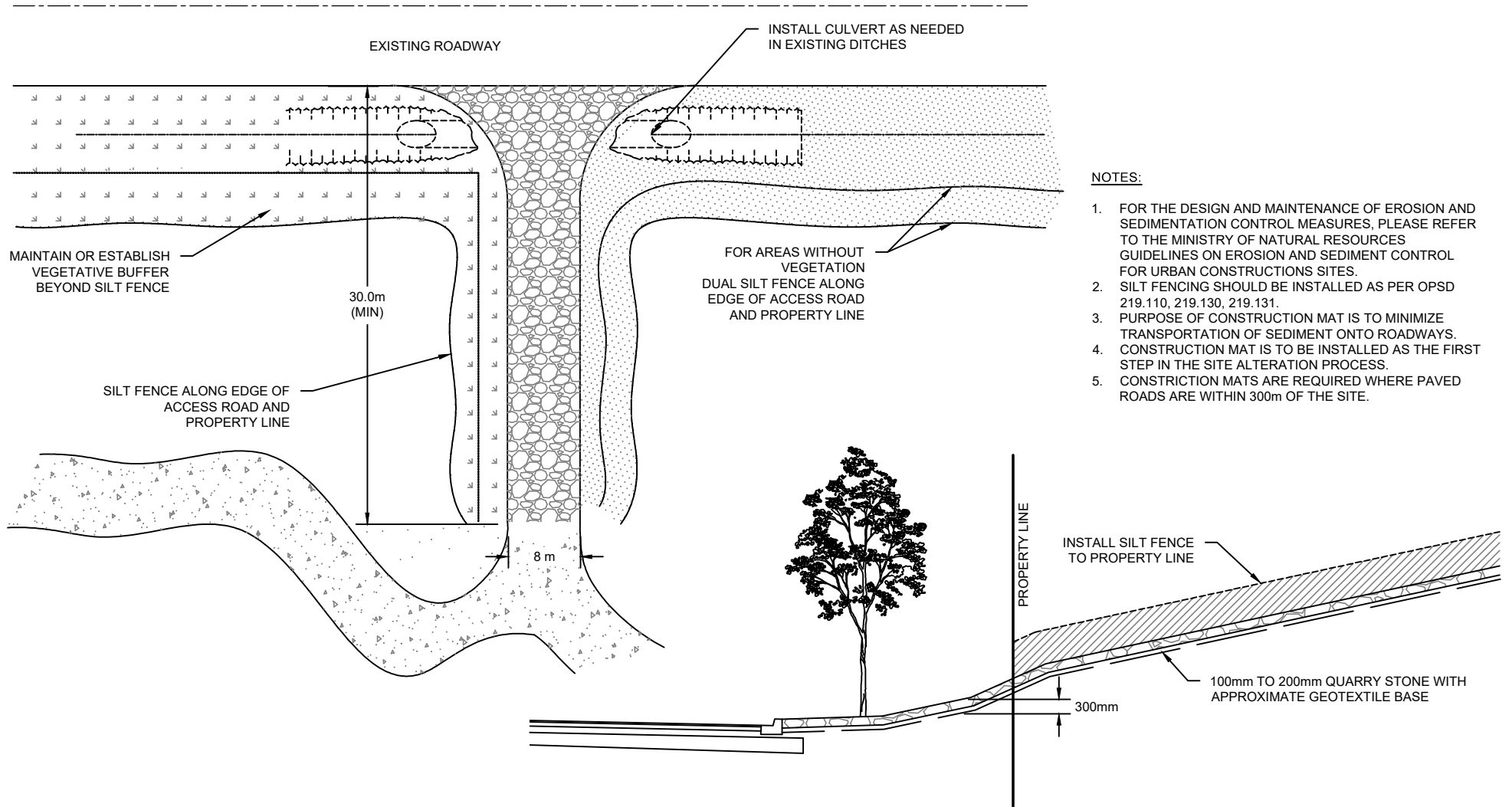

NOTES:

1. FOR THE DESIGN AND MAINTENANCE OF EROSION AND SEDIMENTATION CONTROL MEASURES, PLEASE REFER TO THE MINISTRY OF NATURAL RESOURCES GUIDELINES ON EROSION AND SEDIMENT CONTROL FOR URBAN CONSTRUCTIONS SITES.
2. SILT FENCING SHOULD BE INSTALLED AS PER OPSD 219.110, 219.130, 219.131.
3. PURPOSE OF CONSTRUCTION MAT IS TO MINIMIZE TRANSPORTATION OF SEDIMENT ONTO ROADWAYS.
4. CONSTRUCTION MAT IS TO BE INSTALLED AS THE FIRST STEP IN THE SITE ALTERATION PROCESS.
5. CONSTRUCTION MATS ARE REQUIRED WHERE PAVED ROADS ARE WITHIN 300m OF THE SITE.



STANDARD DETAIL

CONSTRUCTION ENTRANCE MAT

APPROVED

MANAGER OF ENGINEERING DATE

DIRECTOR OF OPERATIONS DATE

REVISION No. DATE: MARCH 2020

SCALE: N.T.S.

TSD-600

NOTES:

1. FOR THE DESIGN AND MAINTENANCE OF EROSION AND SEDIMENTATION CONTROL MEASURES, PLEASE REFER TO THE MINISTRY OF NATURAL RESOURCES GUIDELINES ON EROSION AND SEDIMENT CONTROL FOR URBAN CONSTRUCTIONS SITES.
2. PILES CONTAINING MORE THAN 100 CUBIC METRES OF TOPSOIL OR SPOIL SHALL BE LOCATED AT A MINIMUM OF 15 METRES FROM A ROADWAY AND 30 METRES FROM A WATER COURSE.
3. PILES LEFT IN PLACE FOR MORE THAN 60 DAYS SHALL BE STABILIZED WITH A TARP, MULCH, VEGETATIVE COVER OR OTHER ACCEPTABLE MEANS.

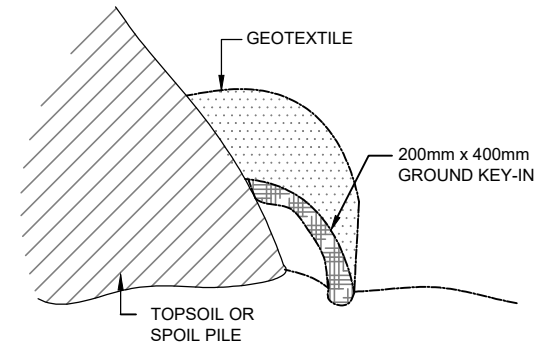

DETAIL A
SILT FENCE DETAIL

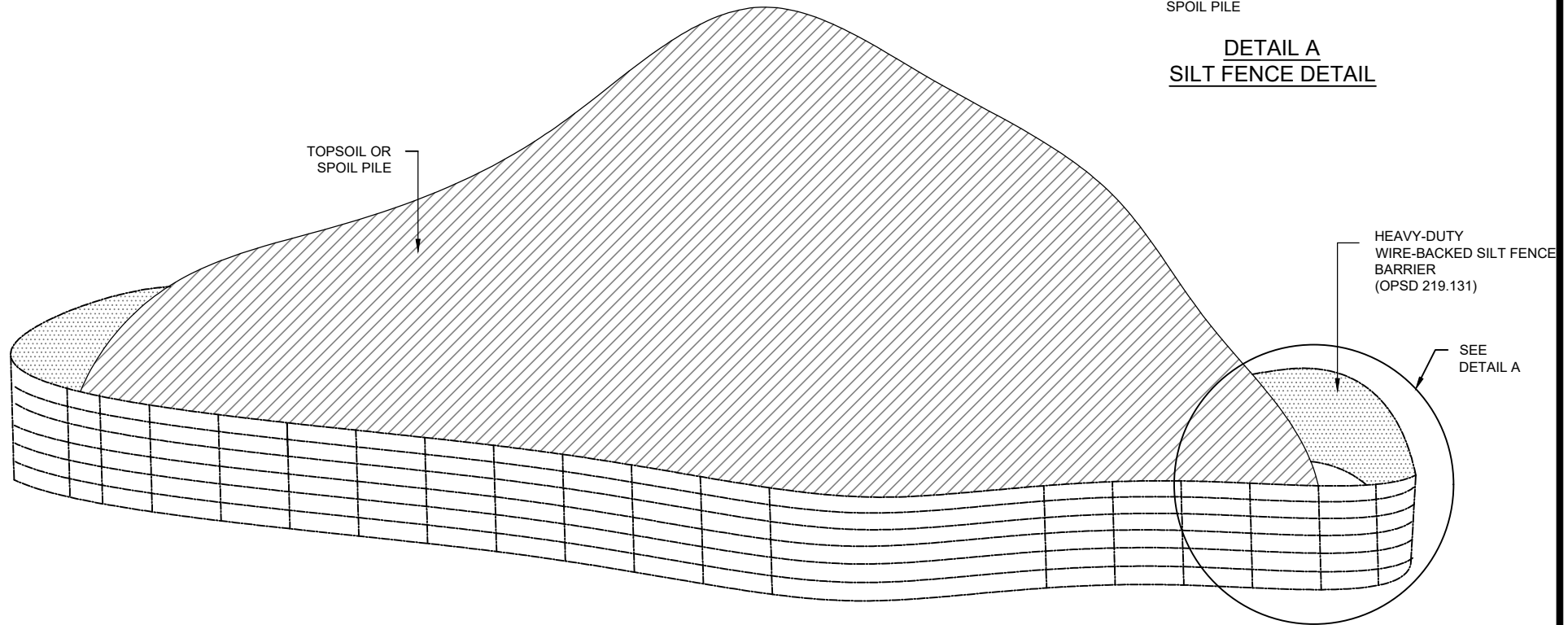

STANDARD DETAIL

**TOPSOIL OR SOIL PILE
SILTATION CONTROL**

APPROVED

MANAGER OF ENGINEERING DATE
DIRECTOR OF OPERATIONS DATE

REVISION No. DATE: MARCH 2020
SCALE: N.T.S.

TSD-601

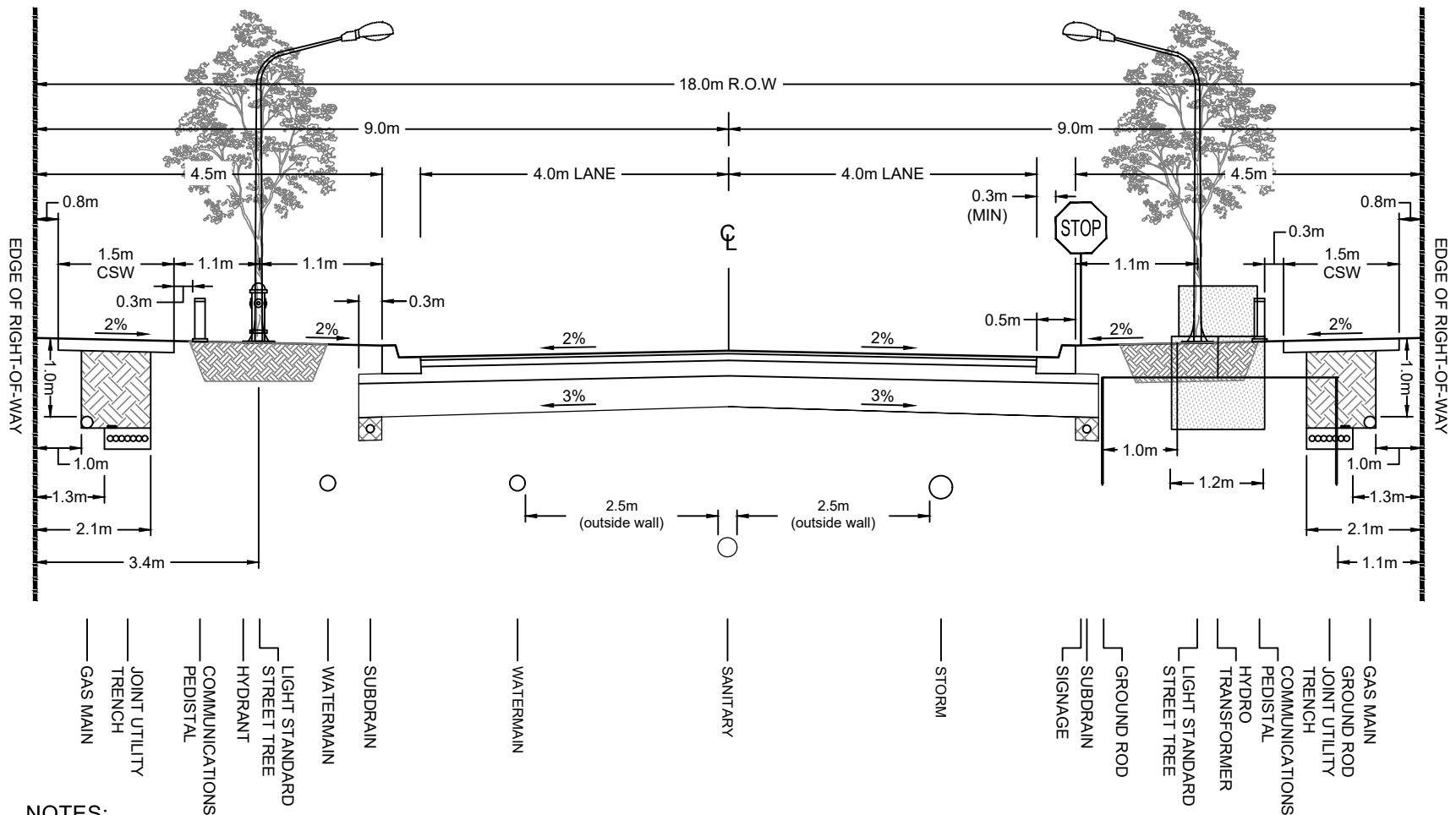

NOTES:

1. WATER DISTRIBUTION, WASTEWATER AND STORMWATER SYSTEMS TO BE DESIGNED IN ACCORDANCE WITH APPLICABLE TOWN OF TILLSONBURG DEVELOPMENT GUIDELINES & DESIGN CRITERIA, OXFORD COUNTY DESIGN GUIDELINES & SPECIFICATIONS, AND ONTARIO PROVINCIAL STANDARDS (OPSS/OPSD).
2. REFER TO SECTION 08 - STREET LIGHTING, TOWN OF TILLSONBURG DEVELOPMENT GUIDELINES & DESIGN CRITERIA AND ASSOCIATED TSD'S FOR LIGHT STANDARD AND POLE BASE LOCATION AND DEPTH.
3. REFER TO SECTION 07 - ROADS, TOWN OF TILLSONBURG DEVELOPMENT GUIDELINES & DESIGN CRITERIA FOR PAVEMENT DESIGN SPECIFICATIONS.
4. REFER TO SECTION 14 - PARKS AND STREETSCAPING, TOWN OF TILLSONBURG DEVELOPMENT GUIDELINES & DESIGN CRITERIA FOR STREET TREE SPECIFICATIONS. LOCATIONS WILL REQUIRE APPROVAL BY THE TOWN OF TILLSONBURG ENGINEERING DEPARTMENT.



STANDARD DETAIL

18.0m LOCAL ROAD
ALLOWANCE
8.0m ASPHALT

APPROVED

MANAGER OF ENGINEERING DATE
DIRECTOR OF OPERATIONS DATE

REVISION No. DATE: DEC 2021
SCALE: N.T.S.

TSD-700

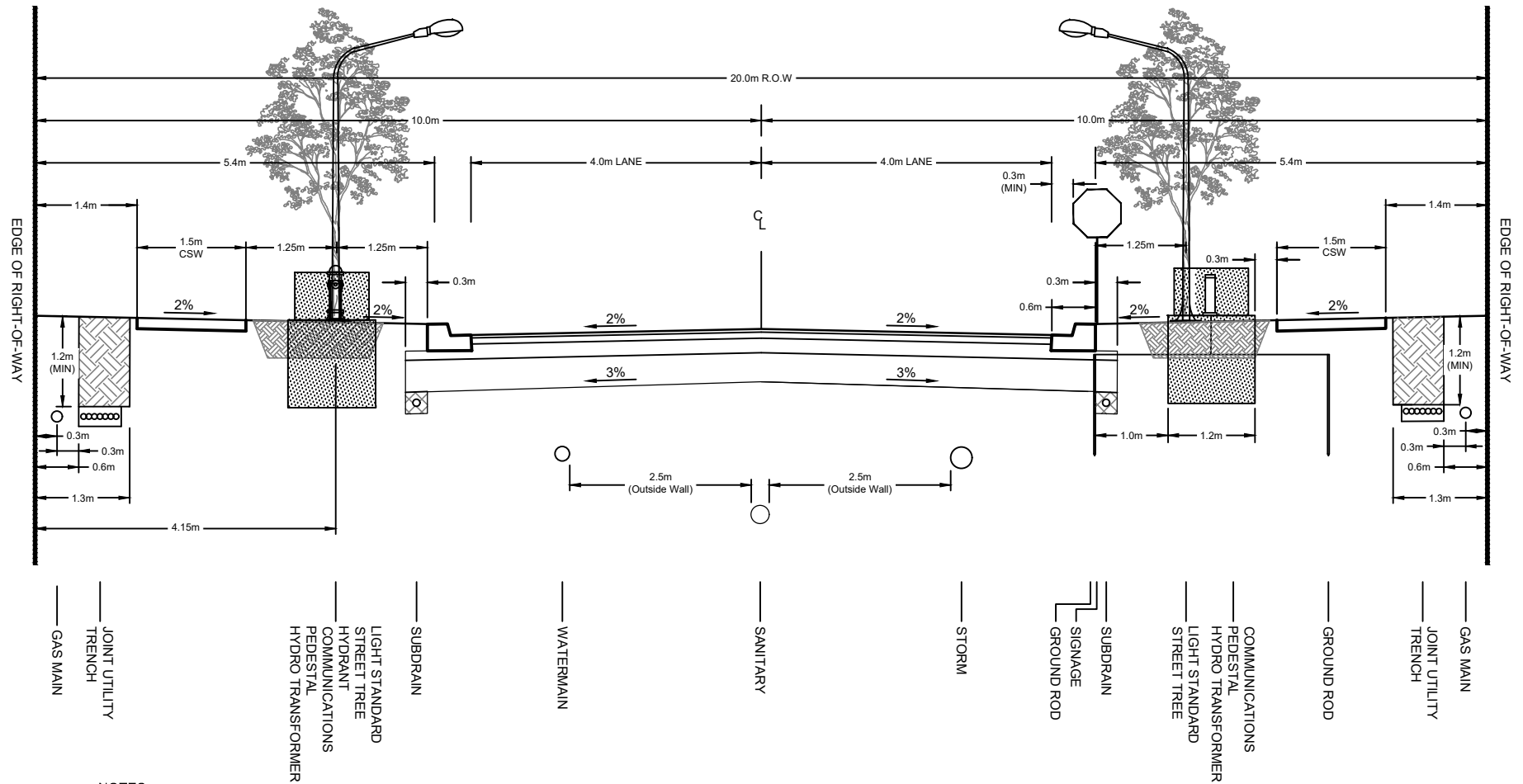

NOTES:

1. WATER DISTRIBUTION, WASTEWATER AND STORMWATER SYSTEMS TO BE DESIGNED IN ACCORDANCE WITH APPLICABLE TOWN OF TILLSONBURG DEVELOPMENT GUIDELINES & DESIGN CRITERIA, OXFORD COUNTY DESIGN GUIDELINES & SPECIFICATIONS, AND ONTARIO PROVINCIAL STANDARDS (OPSS/OPSD).
2. REFER TO SECTION 08 - STREET LIGHTING, TOWN OF TILLSONBURG DEVELOPMENT GUIDELINES & DESIGN CRITERIA AND ASSOCIATED TSD'S FOR LIGHT STANDARD AND POLE BASE LOCATION AND DEPTH.
3. REFER TO SECTION 07 - ROADS, TOWN OF TILLSONBURG DEVELOPMENT GUIDELINES & DESIGN CRITERIA FOR PAVEMENT DESIGN SPECIFICATIONS.
4. REFER TO SECTION 14 - PARKS AND STREETSCAPING, TOWN OF TILLSONBURG DEVELOPMENT GUIDELINES & DESIGN CRITERIA FOR STREET TREE SPECIFICATIONS. LOCATIONS WILL REQUIRE APPROVAL BY THE TOWN OF TILLSONBURG ENGINEERING DEPARTMENT.



STANDARD DETAIL

20.0m LOCAL ROAD ALLOWANCE 8.0m ASPHALT

APPROVED

..... DATE
MANAGER OF ENGINEERING
..... DATE
DIRECTOR OF OPERATIONS

REVISION No. DATE: AUGUST 2022

SCALE: 1:30

TSD-701

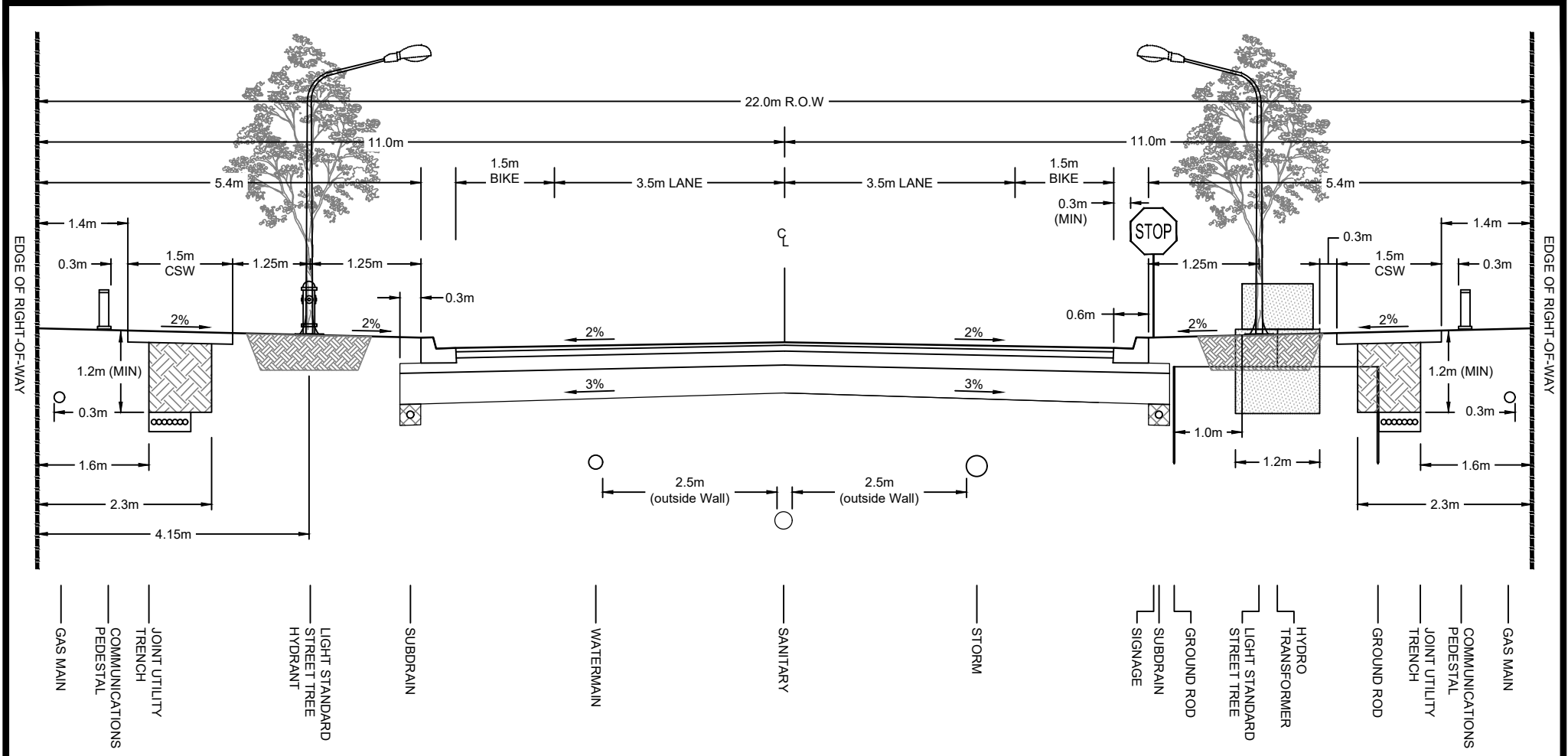

- NOTES:**
1. WATER DISTRIBUTION, WASTEWATER AND STORMWATER SYSTEMS TO BE DESIGNED IN ACCORDANCE WITH APPLICABLE TOWN OF TILLSONBURG DEVELOPMENT GUIDELINES & DESIGN CRITERIA, OXFORD COUNTY DESIGN GUIDELINES & SPECIFICATIONS, AND ONTARIO PROVINCIAL STANDARDS (OPSS/OPSD).
 2. REFER TO SECTION 08 - STREET LIGHTING, TOWN OF TILLSONBURG DEVELOPMENT GUIDELINES & DESIGN CRITERIA AND ASSOCIATED TSD'S FOR LIGHT STANDARD AND POLE BASE LOCATION AND DEPTH.
 3. REFER TO SECTION 07 - ROADS, TOWN OF TILLSONBURG DEVELOPMENT GUIDELINES & DESIGN CRITERIA FOR PAVEMENT DESIGN SPECIFICATIONS.
 4. REFER TO SECTION 14 - PARKS AND STREETSCAPING, TOWN OF TILLSONBURG DEVELOPMENT GUIDELINES & DESIGN CRITERIA FOR STREET TREE SPECIFICATIONS. LOCATIONS WILL REQUIRE APPROVAL BY THE TOWN OF TILLSONBURG ENGINEERING DEPARTMENT.



22.0m COLLECTOR ROAD ALLOWANCE (BIKE LANES) 10.0m ASPHALT

APPROVED

MANAGER OF ENGINEERING DATE

DIRECTOR OF OPERATIONS DATE

REVISION No.	DATE: FEB 2022
	SCALE: N.T.S.
TSD-702	

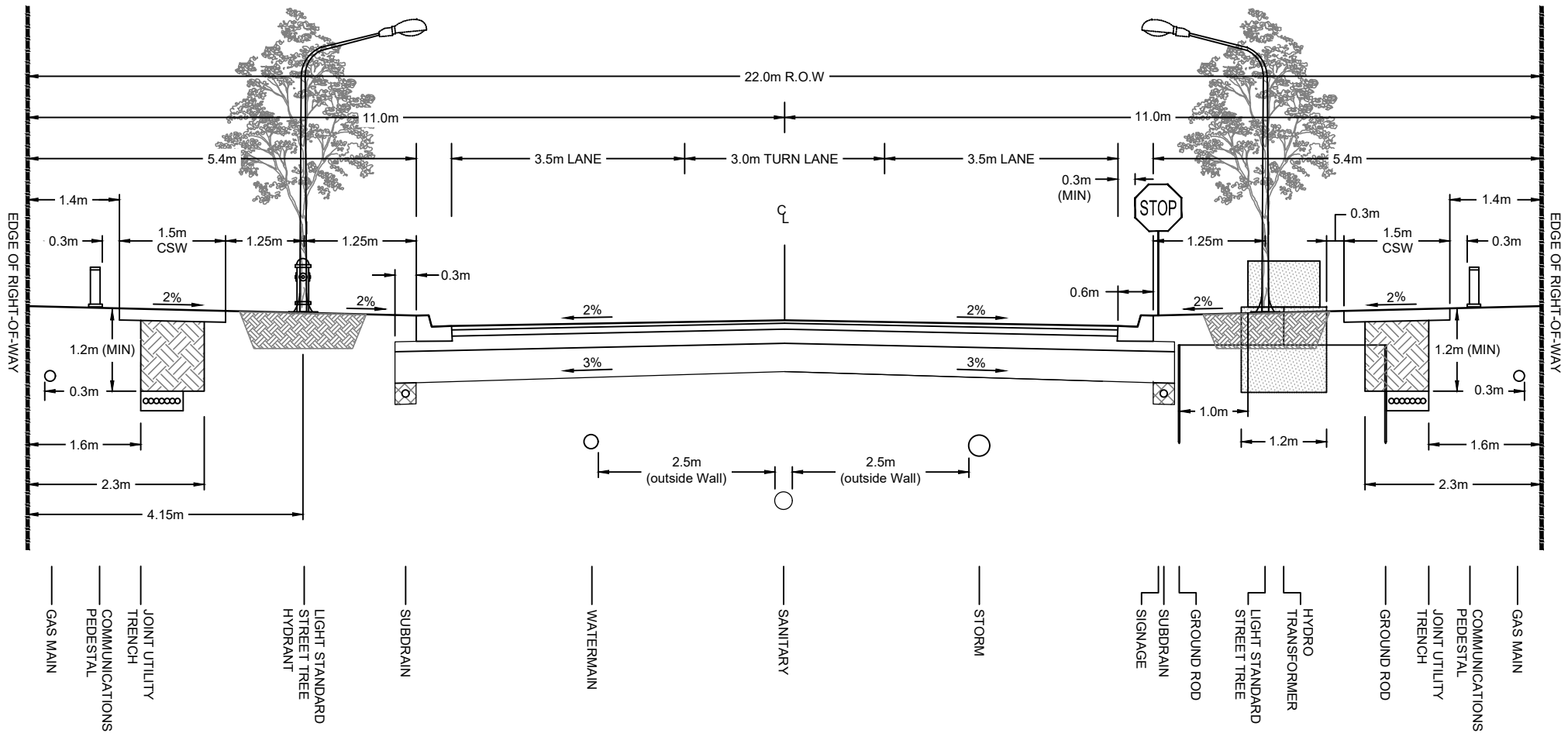

NOTES:

1. WATER DISTRIBUTION, WASTEWATER AND STORMWATER SYSTEMS TO BE DESIGNED IN ACCORDANCE WITH APPLICABLE TOWN OF TILLSONBURG DEVELOPMENT GUIDELINES & DESIGN CRITERIA, OXFORD COUNTY DESIGN GUIDELINES & SPECIFICATIONS, AND ONTARIO PROVINCIAL STANDARDS (OPSS/OPSD).
2. REFER TO SECTION 08 - STREET LIGHTING, TOWN OF TILLSONBURG DEVELOPMENT GUIDELINES & DESIGN CRITERIA AND ASSOCIATED TSD'S FOR LIGHT STANDARD AND POLE BASE LOCATION AND DEPTH.
3. REFER TO SECTION 07 - ROADS, TOWN OF TILLSONBURG DEVELOPMENT GUIDELINES & DESIGN CRITERIA FOR PAVEMENT DESIGN SPECIFICATIONS.
4. REFER TO SECTION 14 - PARKS AND STREETSCLAPING, TOWN OF TILLSONBURG DEVELOPMENT GUIDELINES & DESIGN CRITERIA FOR STREET TREE SPECIFICATIONS. LOCATIONS WILL REQUIRE APPROVAL BY THE TOWN OF TILLSONBURG ENGINEERING DEPARTMENT.
5. WIDENING MAY BE REQUIRED AT INTERSECTIONS TO ACCOMMODATE REQUIRED TURN-LANES.



STANDARD DETAIL

22.0m COLLECTOR ROAD
ALLOWANCE (TURN LANE)
10.0m ASPHALT

APPROVED

MANAGER OF ENGINEERING DATE
DIRECTOR OF OPERATIONS DATE

REVISION No. DATE: FEB 2022
SCALE: N.T.S.

TSD-703

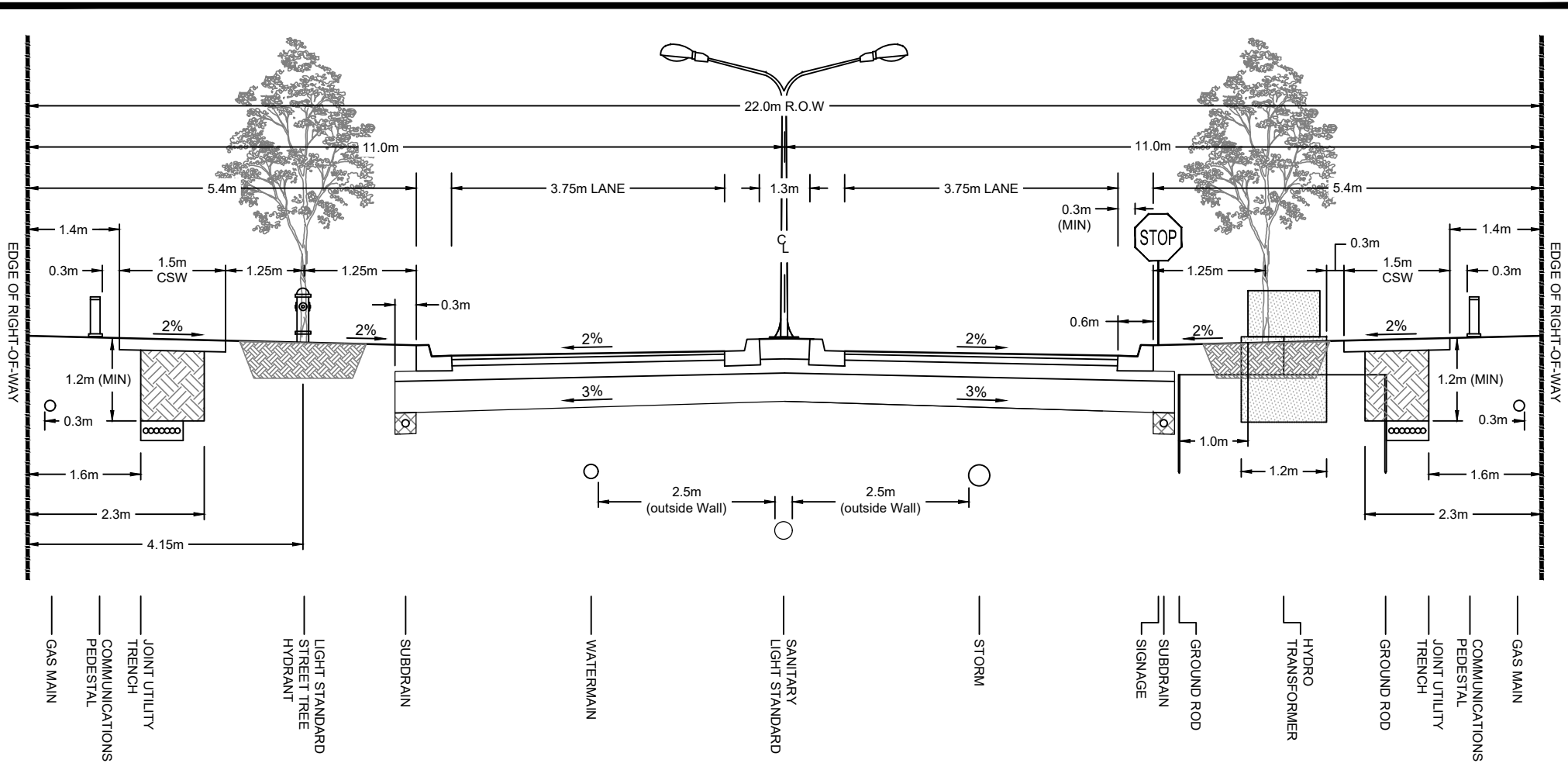

NOTES:

1. WATER DISTRIBUTION, WASTEWATER AND STORMWATER SYSTEMS TO BE DESIGNED IN ACCORDANCE WITH APPLICABLE TOWN OF TILLSONBURG DEVELOPMENT GUIDELINES & DESIGN CRITERIA, OXFORD COUNTY DESIGN GUIDELINES & SPECIFICATIONS, AND ONTARIO PROVINCIAL STANDARDS (OPSS/OPSD).
2. REFER TO SECTION 08 - STREET LIGHTING, TOWN OF TILLSONBURG DEVELOPMENT GUIDELINES & DESIGN CRITERIA AND ASSOCIATED TSD'S FOR LIGHT STANDARD AND POLE BASE LOCATION AND DEPTH.
3. REFER TO SECTION 07 - ROADS, TOWN OF TILLSONBURG DEVELOPMENT GUIDELINES & DESIGN CRITERIA FOR PAVEMENT DESIGN SPECIFICATIONS.
4. REFER TO SECTION 14 - PARKS AND STREETSCAPING, TOWN OF TILLSONBURG DEVELOPMENT GUIDELINES & DESIGN CRITERIA FOR STREET TREE SPECIFICATIONS. LOCATIONS WILL REQUIRE APPROVAL BY THE TOWN OF TILLSONBURG ENGINEERING DEPARTMENT.



STANDARD DETAIL

22.0m COLLECTOR ROAD ALLOWANCE (MEDIAN) 10.0m ASPHALT

APPROVED

MANAGER OF ENGINEERING DATE

DIRECTOR OF OPERATIONS DATE

REVISION No. DATE: FEB 2022

SCALE: N.T.S.

TSD-704

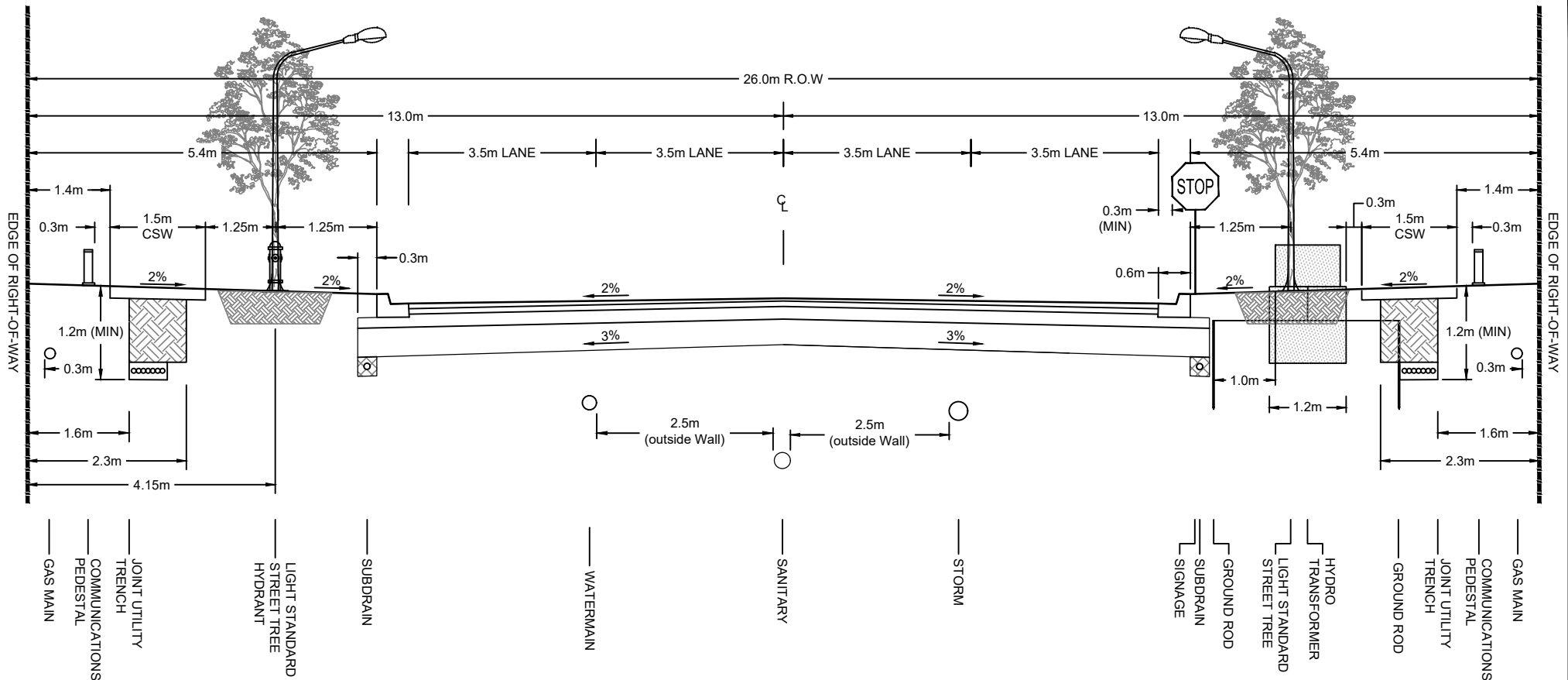

NOTES:

1. WATER DISTRIBUTION, WASTEWATER AND STORMWATER SYSTEMS TO BE DESIGNED IN ACCORDANCE WITH APPLICABLE TOWN OF TILLSONBURG DEVELOPMENT GUIDELINES & DESIGN CRITERIA, OXFORD COUNTY DESIGN GUIDELINES & SPECIFICATIONS, AND ONTARIO PROVINCIAL STANDARDS (OPSS/OPSD).
2. REFER TO SECTION 08 - STREET LIGHTING, TOWN OF TILLSONBURG DEVELOPMENT GUIDELINES & DESIGN CRITERIA AND ASSOCIATED TSD'S FOR LIGHT STANDARD AND POLE BASE LOCATION AND DEPTH.
3. REFER TO SECTION 07 - ROADS, TOWN OF TILLSONBURG DEVELOPMENT GUIDELINES & DESIGN CRITERIA FOR PAVEMENT DESIGN SPECIFICATIONS.
4. REFER TO SECTION 14 - PARKS AND STREETSCAPING, TOWN OF TILLSONBURG DEVELOPMENT GUIDELINES & DESIGN CRITERIA FOR STREET TREE SPECIFICATIONS. LOCATIONS WILL REQUIRE APPROVAL BY THE TOWN OF TILLSONBURG ENGINEERING DEPARTMENT.



STANDARD DETAIL

26.0m ARTERIAL ROAD
ALLOWANCE
14.0m ASPHALT

APPROVED

MANAGER OF ENGINEERING DATE
DIRECTOR OF OPERATIONS DATE

REVISION No. DATE: FEB 2022
SCALE: N.T.S.

TSD-705

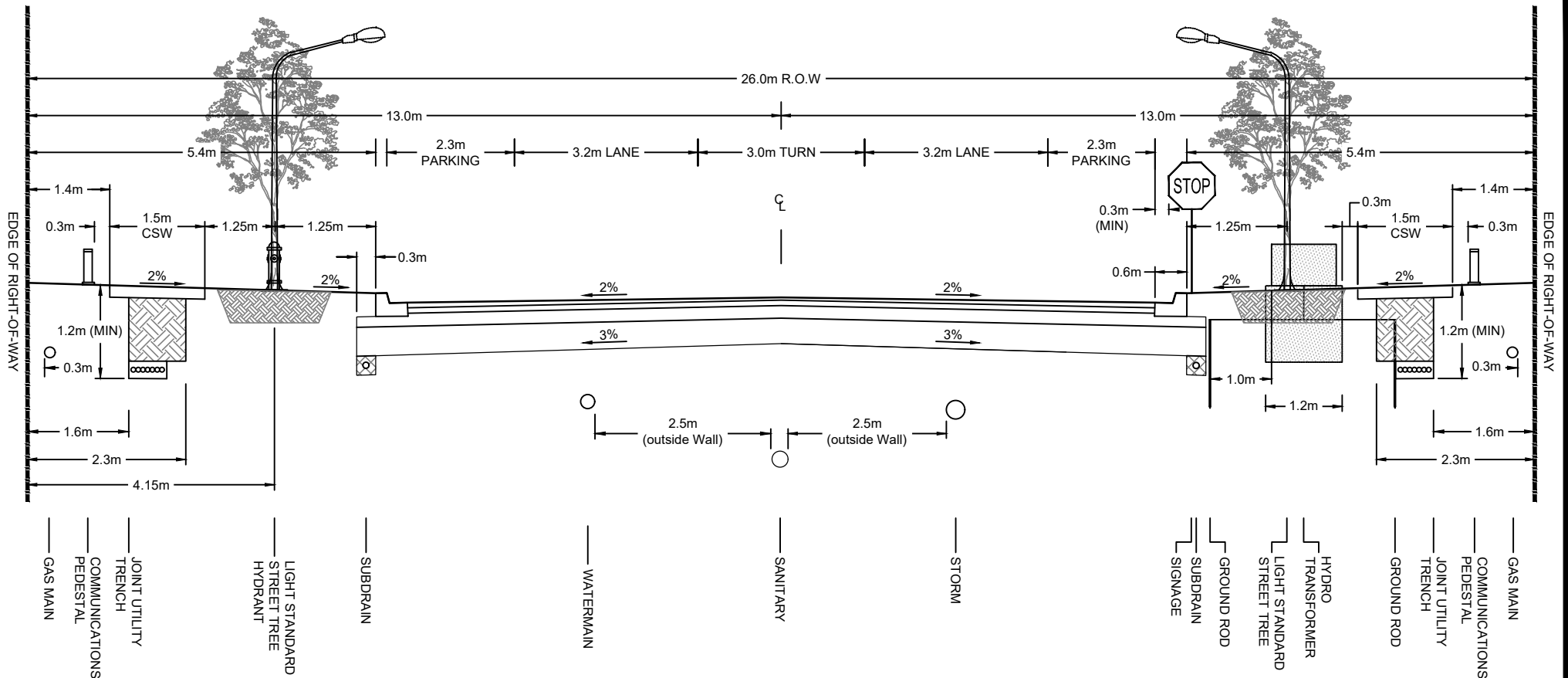

NOTES:

1. WATER DISTRIBUTION, WASTEWATER AND STORMWATER SYSTEMS TO BE DESIGNED IN ACCORDANCE WITH APPLICABLE TOWN OF TILLSONBURG DEVELOPMENT GUIDELINES & DESIGN CRITERIA, OXFORD COUNTY DESIGN GUIDELINES & SPECIFICATIONS, AND ONTARIO PROVINCIAL STANDARDS (OPSS/OPSD).
2. REFER TO SECTION 08 - STREET LIGHTING, TOWN OF TILLSONBURG DEVELOPMENT GUIDELINES & DESIGN CRITERIA AND ASSOCIATED TSD'S FOR LIGHT STANDARD AND POLE BASE LOCATION AND DEPTH.
3. REFER TO SECTION 07 - ROADS, TOWN OF TILLSONBURG DEVELOPMENT GUIDELINES & DESIGN CRITERIA FOR PAVEMENT DESIGN SPECIFICATIONS.
4. REFER TO SECTION 14 - PARKS AND STREETSCLAPING, TOWN OF TILLSONBURG DEVELOPMENT GUIDELINES & DESIGN CRITERIA FOR STREET TREE SPECIFICATIONS. LOCATIONS WILL REQUIRE APPROVAL BY THE TOWN OF TILLSONBURG ENGINEERING DEPARTMENT.
5. WIDENING MAY BE REQUIRED AT INTERSECTIONS TO ACCOMMODATE REQUIRED TURN-LANES.



STANDARD DETAIL

26.0m ARTERIAL ROAD ALLOWANCE (PARKING)

14.0m ASPHALT

APPROVED

MANAGER OF ENGINEERING DATE

DIRECTOR OF OPERATIONS DATE

REVISION No. DATE: FEB 2022

SCALE: N.T.S.

TSD-706

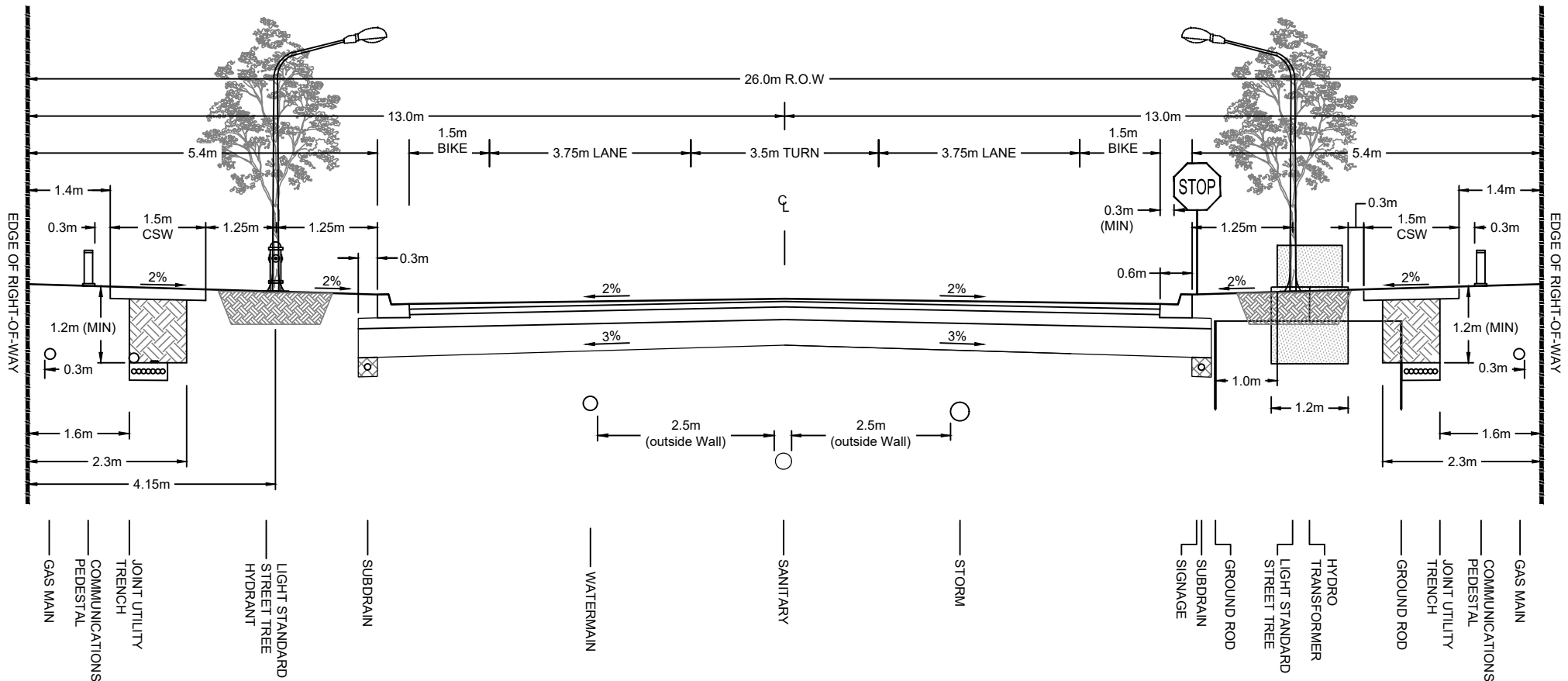

NOTES:

1. WATER DISTRIBUTION, WASTEWATER AND STORMWATER SYSTEMS TO BE DESIGNED IN ACCORDANCE WITH APPLICABLE TOWN OF TILLSONBURG DEVELOPMENT GUIDELINES & DESIGN CRITERIA, OXFORD COUNTY DESIGN GUIDELINES & SPECIFICATIONS, AND ONTARIO PROVINCIAL STANDARDS (OPSS/OPSD).
2. REFER TO SECTION 08 - STREET LIGHTING, TOWN OF TILLSONBURG DEVELOPMENT GUIDELINES & DESIGN CRITERIA AND ASSOCIATED TSD'S FOR LIGHT STANDARD AND POLE BASE LOCATION AND DEPTH.
3. REFER TO SECTION 07 - ROADS, TOWN OF TILLSONBURG DEVELOPMENT GUIDELINES & DESIGN CRITERIA FOR PAVEMENT DESIGN SPECIFICATIONS.
4. REFER TO SECTION 14 - PARKS AND STREETSCAPING, TOWN OF TILLSONBURG DEVELOPMENT GUIDELINES & DESIGN CRITERIA FOR STREET TREE SPECIFICATIONS. LOCATIONS WILL REQUIRE APPROVAL BY THE TOWN OF TILLSONBURG ENGINEERING DEPARTMENT.
5. WIDENING MAY BE REQUIRED AT INTERSECTIONS TO ACCOMMODATE REQUIRED TURN-LANES.



**26.0m ARTERIAL ROAD ALLOWANCE (BIKE LANES)
14.0m ASPHALT**

APPROVED

MANAGER OF ENGINEERING DATE
DIRECTOR OF OPERATIONS DATE

REVISION No. DATE: FEB 2022
SCALE: N.T.S.

TSD-707

STANDARD DETAIL

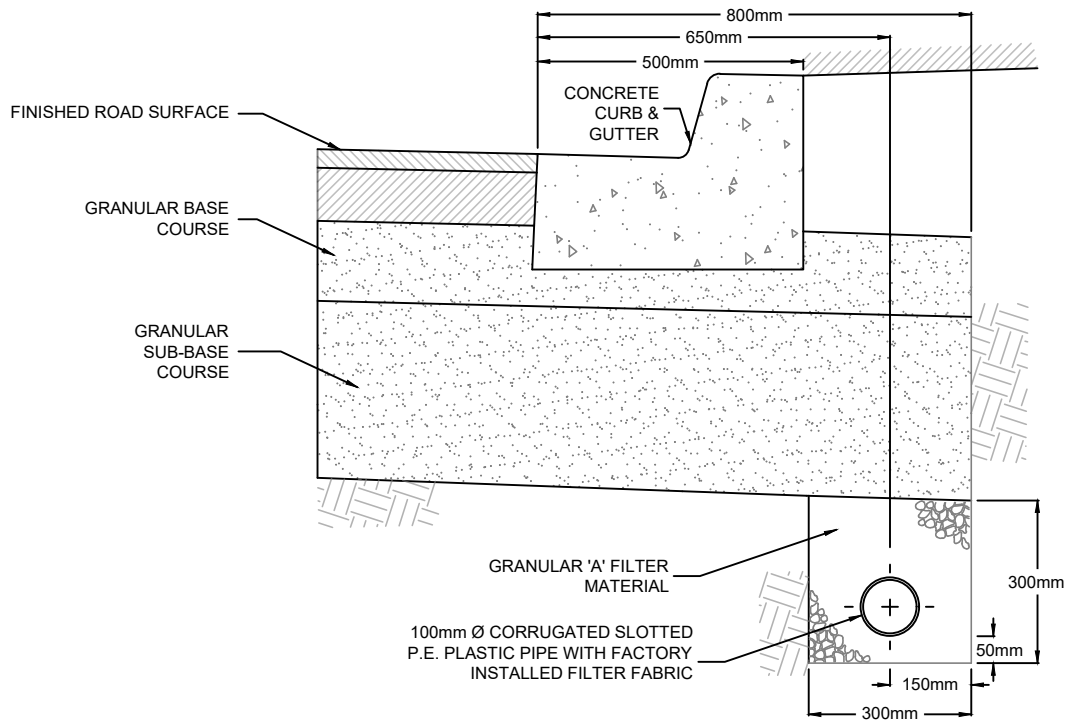

TYPE 'A' - TYPICAL

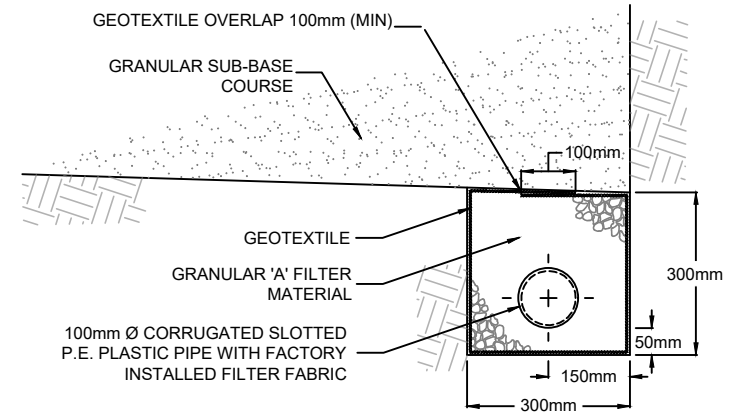

TYPE 'B' - HIGH GROUND WATER

NOTES:

1. ALL CONNECTIONS TO BE MADE ON THE UPSTREAM SIDE OF ALL CATCH BASINS. MORTARED INSIDE AND OUTSIDE.
2. SUBDRAINS TO BE PLUGGED AT THE HIGH END WITH A MANUFACTURED PLUG.
3. ALL DIMENSIONS ARE IN MILLIMETRES UNLESS OTHERWISE SHOWN.
4. FOR SELECTION OF TYPE 'A' AND TYPE 'B' SUBDRAINS REFER TO TOWN OF TILLSONBURG DEVELOPMENT GUIDELINES AND DESIGN CRITERIA.
5. TYPE 'B' : THE SUBDRAIN TRENCH SHALL BE LINED WITH CLASS II, NON-WOVEN GEOTEXTILE, WITH AN F.D.S. OF 75-150 μ m AND A MINIMUM THICKNESS OF 1 mm.



STANDARD DETAIL

**TYPICAL 100mm SUBDRAIN
DETAIL**

APPROVED

MANAGER OF ENGINEERING DATE
DIRECTOR OF OPERATIONS DATE

REVISION No. DATE: MARCH 2020
SCALE: N.T.S.

TSD-710

WIDTH SHALL BE IN ACCORDANCE WITH THE TOWN OF TILLSONBURG DEVELOPMENT GUIDELINES AND DESIGN CRITERIA

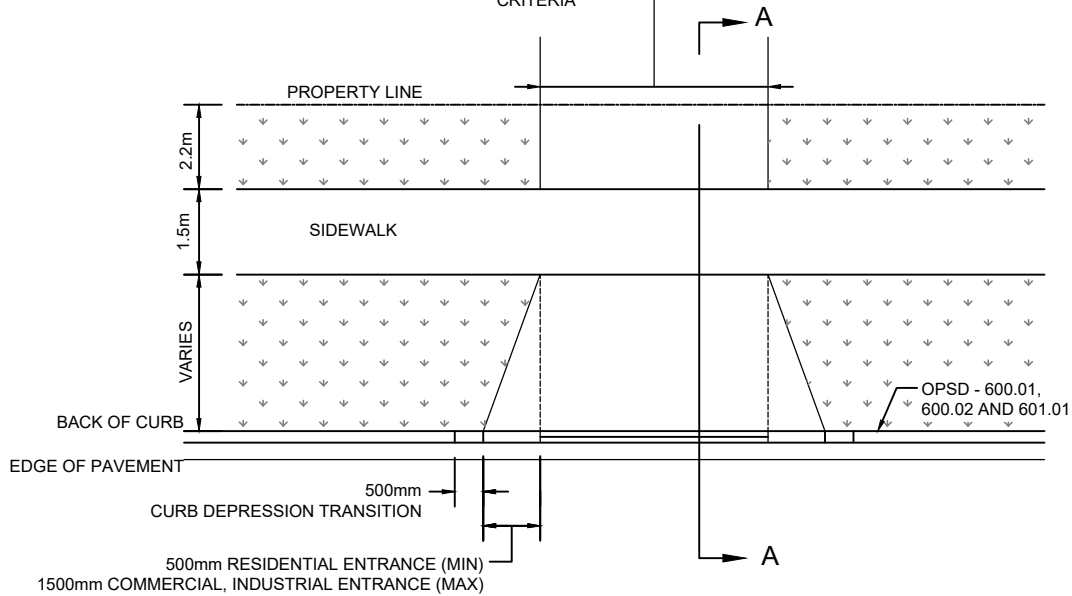

PLAN

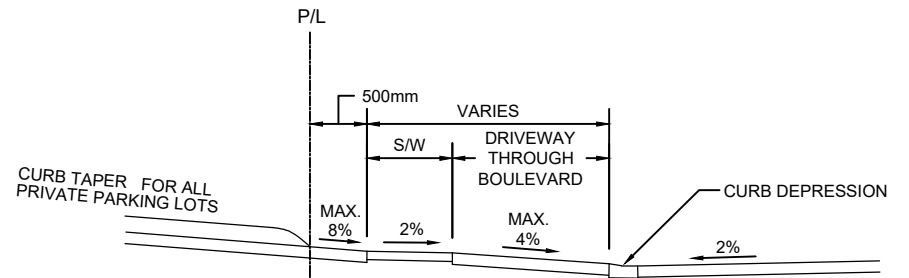

SECTION A-A

NOTES:

1. CROSSFALL OF SIDEWALK 2.0% UNLESS OTHERWISE APPROVED BY TOWN OF TILLSONBURG ENGINEERING DEPARTMENT.
2. ALL DIMENSIONS ARE IN MILLIMETRES UNLESS OTHERWISE SHOWN.
3. REVERSE GRADES WILL NOT BE ACCEPTED.



STANDARD DETAIL

DRIVEWAY AND ENTRANCE DETAIL

APPROVED

MANAGER OF ENGINEERING DATE
 DIRECTOR OF OPERATIONS DATE

REVISION No. DATE: DEC 2021
 SCALE: N.T.S.

TSD-711

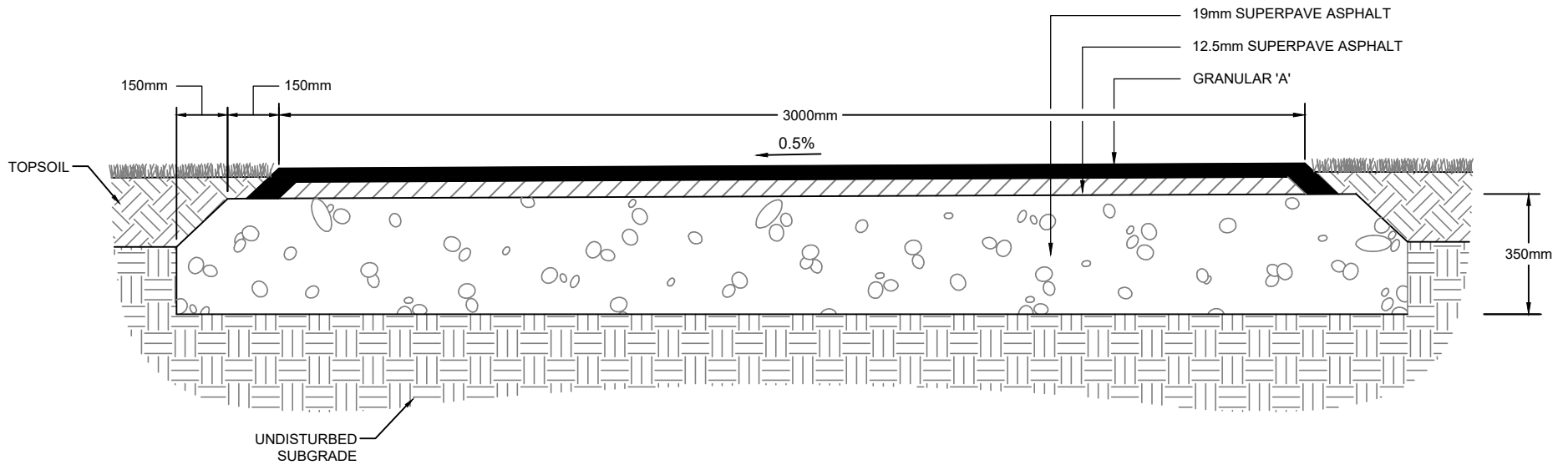

NOTES:

1. ASPHALT SHALL BE PLACED AND SPREAD USING A MECHANICAL PAVER.
2. ASPHALT LAYERS (AFTER ROLLING) TO BE COMPACTED TO A MINIMUM 97% S.P.M.D.D.
3. IN THE EVENT OF UNSUITABLE SUB-GRADE MATERIAL, BASE IS TO BE OVER-EXCAVATED AND BACKFILLED WITH GRANULAR 'B' COMPACTED TO 98% S.P.M.D.D.
4. ALL BACKFILL TO BE COMPACTED IN LIFTS OF 100mm.
5. ENSURE POSITIVE DRAINAGE.
6. TAMP ALL EDGES TO A FIRM 45 DEGREE BEVEL.
7. ALL DIMENSIONS ARE IN MILLIMETRES UNLESS OTHERWISE SHOWN.



STANDARD DETAIL

BOULEVARD PATHWAY

APPROVED

MANAGER OF ENGINEERING DATE

DIRECTOR OF OPERATIONS DATE

REVISION No. DATE: DEC 2021

SCALE: N.T.S.

TSD-712

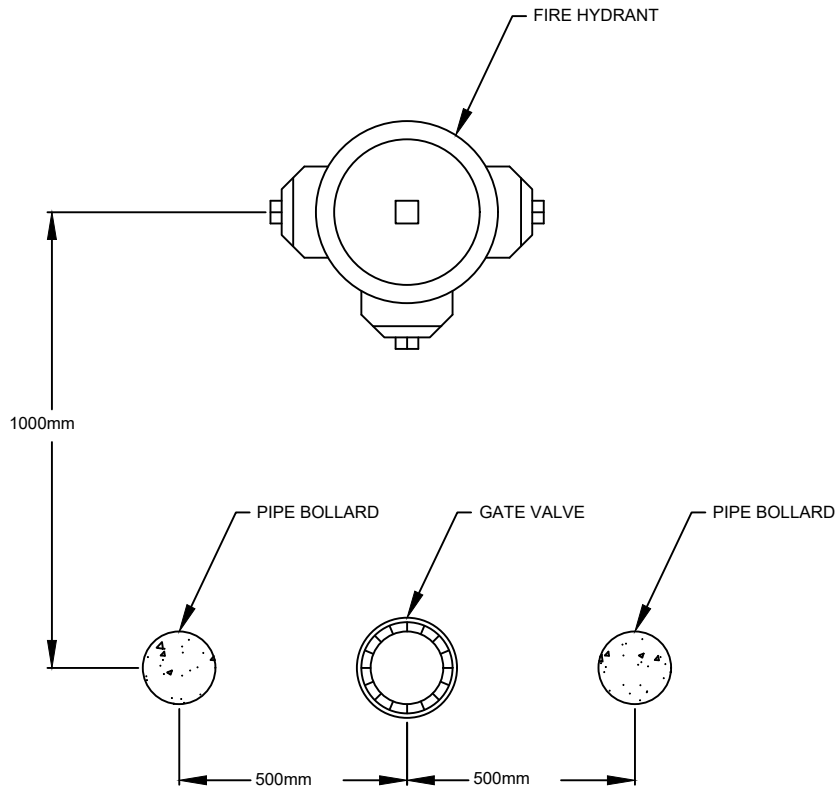

NOTES:

1. DIMENSION MAY BE REDUCED TO SUIT AVAILABLE SPACE IN BOULEVARD AREA (DIMENSION - PROVIDED SPACE IS AVAILABLE).
2. ALL DIMENSIONS ARE IN MILLIMETRES UNLESS NOTED OTHERWISE.
3. REQUIRED NUMBER OF BOLLARDS AND LOCATIONS MAY VARY WITH DIRECTION OF HAZARD(S).

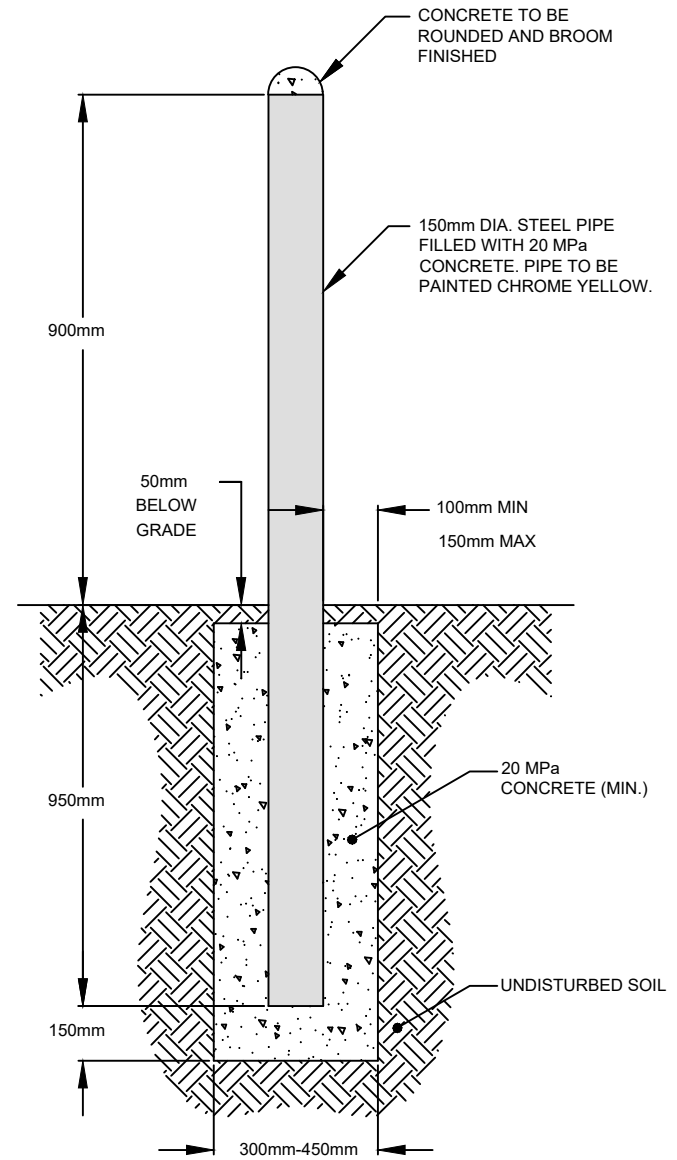

STANDARD DETAIL

PIPE BOLLARD

APPROVED

MANAGER OF ENGINEERING DATE
 DIRECTOR OF OPERATIONS DATE

REVISION No. DATE: MARCH 2020
 SCALE: N.T.S.

TSD-713

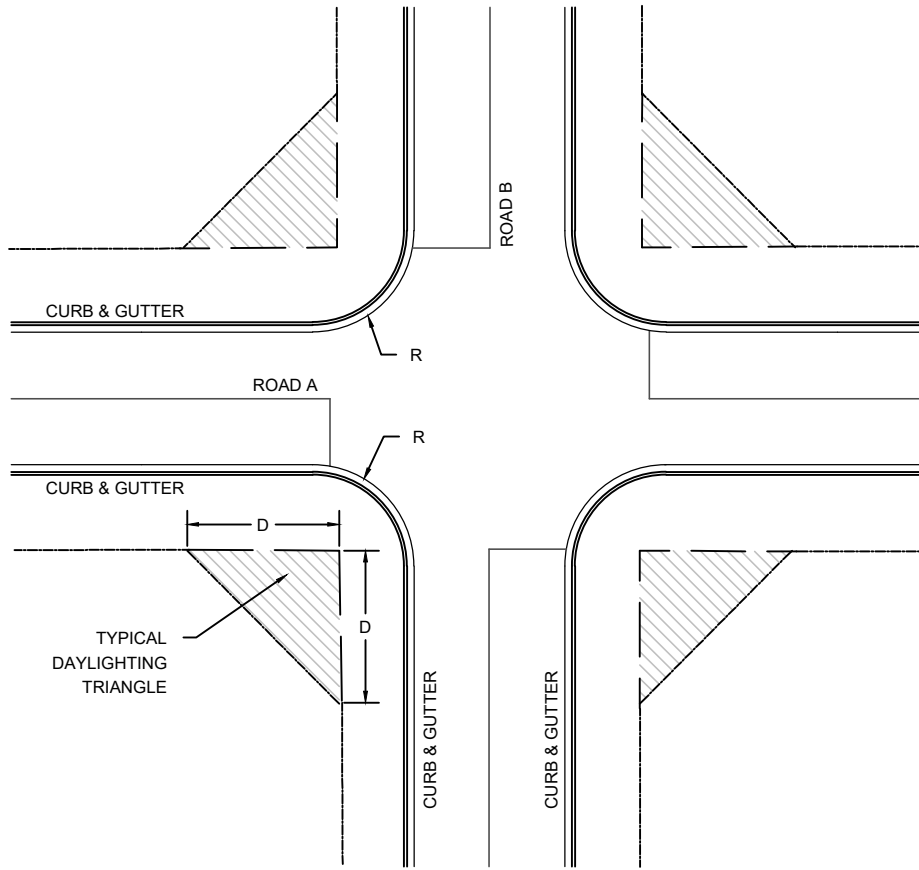

INTERSECTION TYPE ROAD "A" TO ROAD "B"	CURB RADIUS R (m)	D (m)
LOCAL TO LOCAL	7.5	3X3
LOCAL TO COLLECTOR	9.0	5X7
LOCAL TO ARTERIAL	9.0	5X10
COLLECTOR TO COLLECTOR	12.0	7X7
COLLECTOR TO ARTERIAL	12.0	7X10
ARTERIAL TO ARTERIAL	15.0	10X10
INDUSTRIAL TO ANY OTHER STREET	18.0	12X12

NOTES:

1. CURB RADII IN TABLE ARE FROM 90-DEGREE INTERSECTIONS. OTHER INTERSECTION ANGLES WILL REQUIRE DIFFERENT RADII TO ACCOMMODATE THE SAME DESIGN VEHICLE.
2. DESIGN CRITERIA TO CONFORM WITH MTO DOCUMENT GEOMETRIC DESIGN STANDARDS FOR CANADIAN ROADS (METRIC) AND TOWN OF TILLSONBURG DEVELOPMENT GUIDELINES & DESIGN CRITERIA.
3. ALL DIMENSIONS ARE IN METRES UNLESS OTHERWISE SHOWN.



STANDARD DETAIL

TYPICAL DAYLIGHTING REQUIREMENTS

APPROVED

MANAGER OF ENGINEERING DATE
 DIRECTOR OF OPERATIONS DATE

REVISION No. DATE: MARCH 2020
 SCALE: N.T.S.

TSD-720

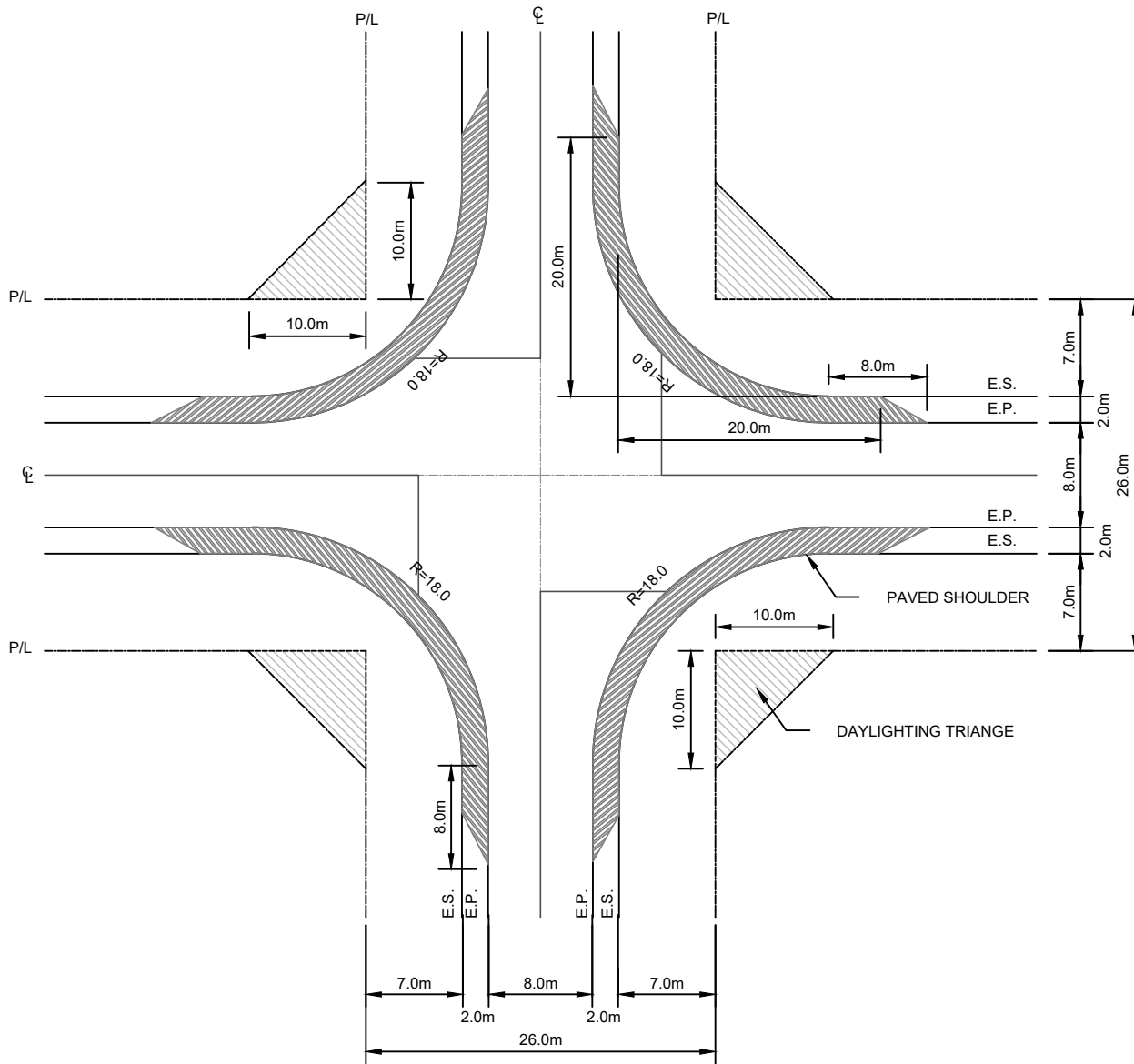

NOTES:

1. PAVED SHOULDER TO HAVE THE SAME DEPTH OF ASPHALT AS THE ROADWAY.
2. ALL DIMENSIONS ARE IN METRES UNLESS OTHERWISE SHOWN.
3. ASPHALT SHOULDER TO EXTEND 8.0m BEYOND THE CURVE TERMINATION POINT.



STANDARD DETAIL

**TYPICAL INTERSECTION
SEMI-URBAN
18m RADIUS 26m R.O.W.**

APPROVED

MANAGER OF ENGINEERING DATE
DIRECTOR OF OPERATIONS DATE

REVISION No. DATE: MARCH 2020
SCALE: N.T.S.

TSD-721

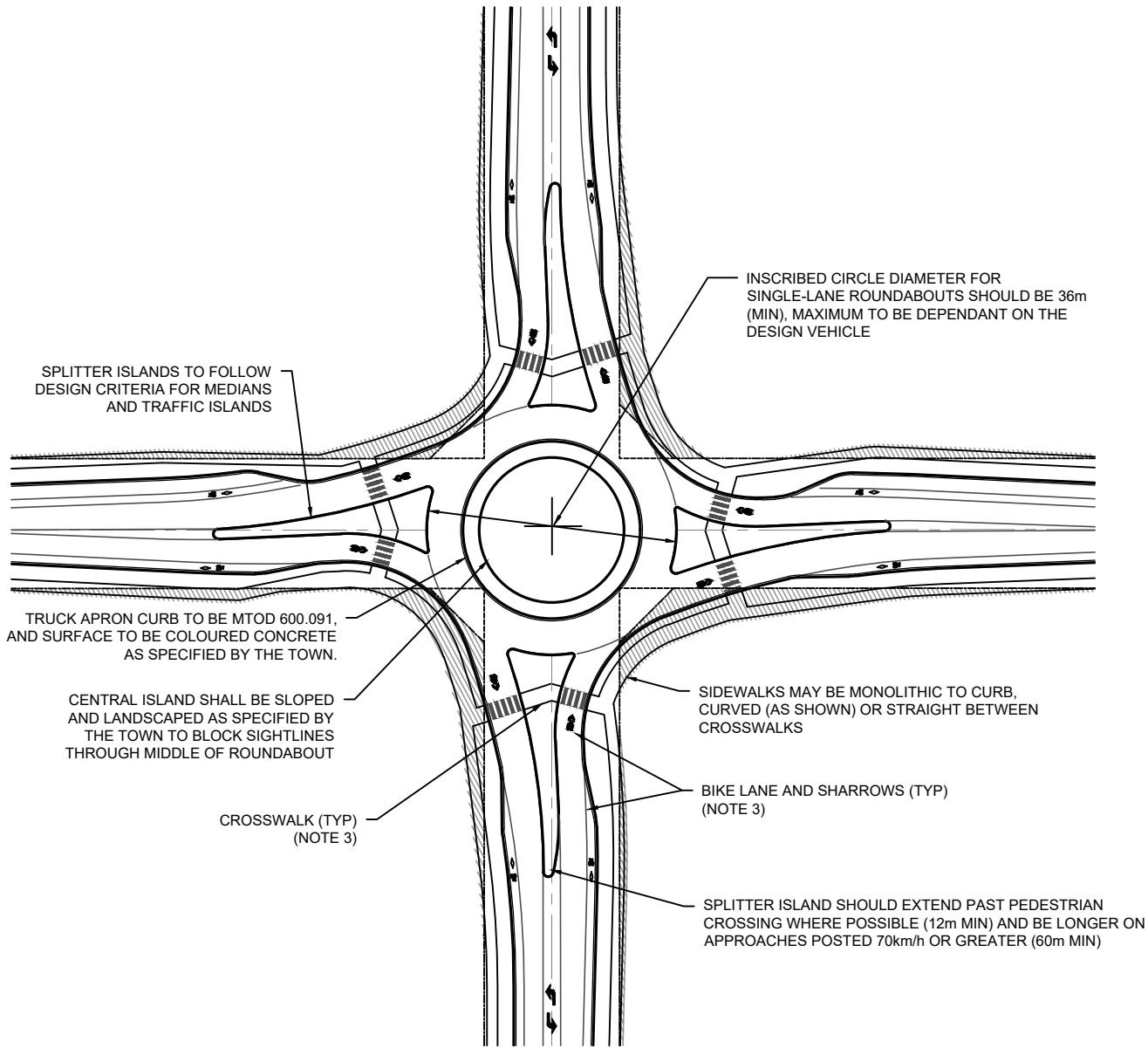

NOTES:

1. LAYOUT IS TYPICAL AND SHOULD BE REFINED THROUGH FURTHER DESIGN
2. ROUNDABOUT SIGNAGE AND MARKINGS TO FOLLOW THE MUTCD FOR CANADA
3. REFER TO TSD-723 FOR BIKE LANE, SHARROWS AND CROSSWALK TYPICALS.



STANDARD DETAIL

ROUNDABOUT SINGLE-LANE

APPROVED

.....
MANAGER OF ENGINEERING DATE

.....
DIRECTOR OF OPERATIONS DATE

REVISION No. DATE: MARCH 2020

SCALE: N.T.S.

TSD-722

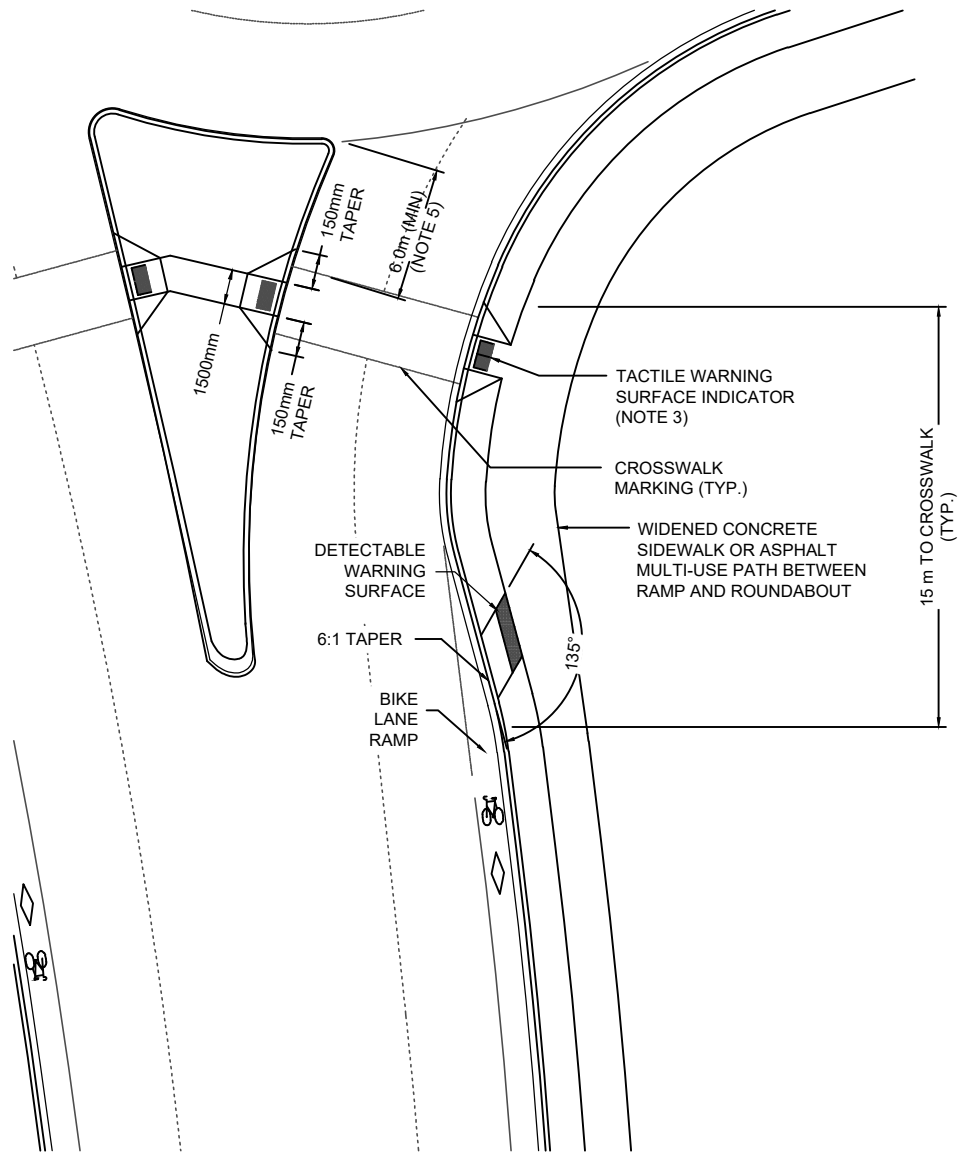

NOTES:

1. LAYOUT IS TYPICAL AND SHOULD BE REFINED THROUGH FURTHER DESIGN
2. FOR ADDITIONAL SIDEWALK RAMPING DETAILS REFER TO OPSDs 310.030, 310.031, 310.033.
3. FOR TACTILE WARNING SURFACE INDICATOR DETAILS, REFER TO OPSD 310.039
4. FOR CROSSWALK MARKINGS AND SIGNAGE REFER TO OTM BOOK 15
5. 12m RECOMMENDED WITH LEVEL 2 PEDESTRIAN CROSSOVER
6. FOR BIKE FACILITY MARKINGS AND SIGNAGE REFER TO OTM BOOK 18
7. ALL DIMENSIONS IN MILLIMETRES UNLESS OTHERWISE NOTED.



STANDARD DETAIL

SIDEWALK RAMPS, BIKE LANES, CROSSWALKS AT ROUNDABOUTS

APPROVED

.....
 MANAGER OF ENGINEERING DATE

 DIRECTOR OF OPERATIONS DATE

REVISION No.	DATE: MARCH 2020
	SCALE: N.T.S.

TSD-723

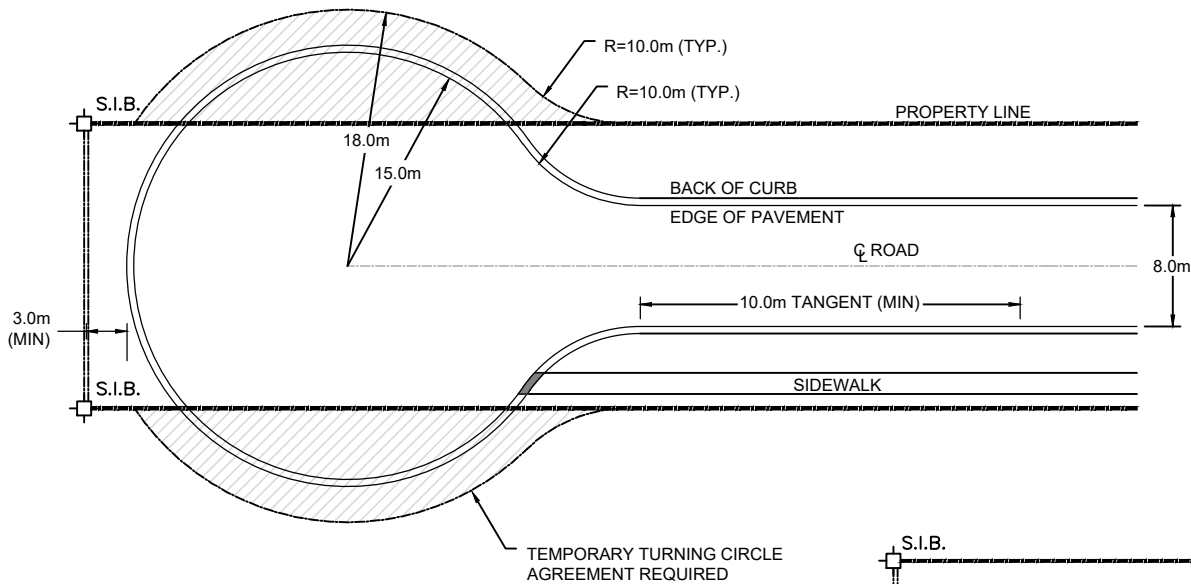

TYPE 'A'

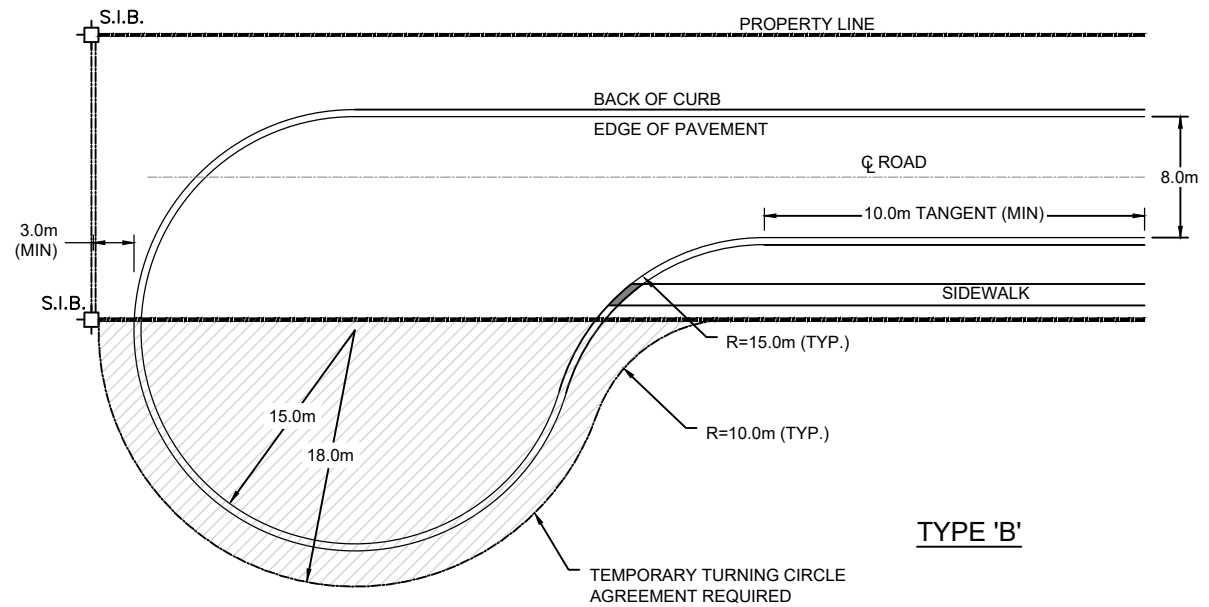

TYPE 'B'

NOTES:

1. ALL DIMENSIONS IN METRES UNLESS OTHERWISE NOTED.



STANDARD DETAIL

**TEMPORARY RESIDENTIAL
CUL-DE-SAC**

APPROVED

MANAGER OF ENGINEERING DATE
DIRECTOR OF OPERATIONS DATE

REVISION No. DATE: MARCH 2020
SCALE: N.T.S.

TSD-730

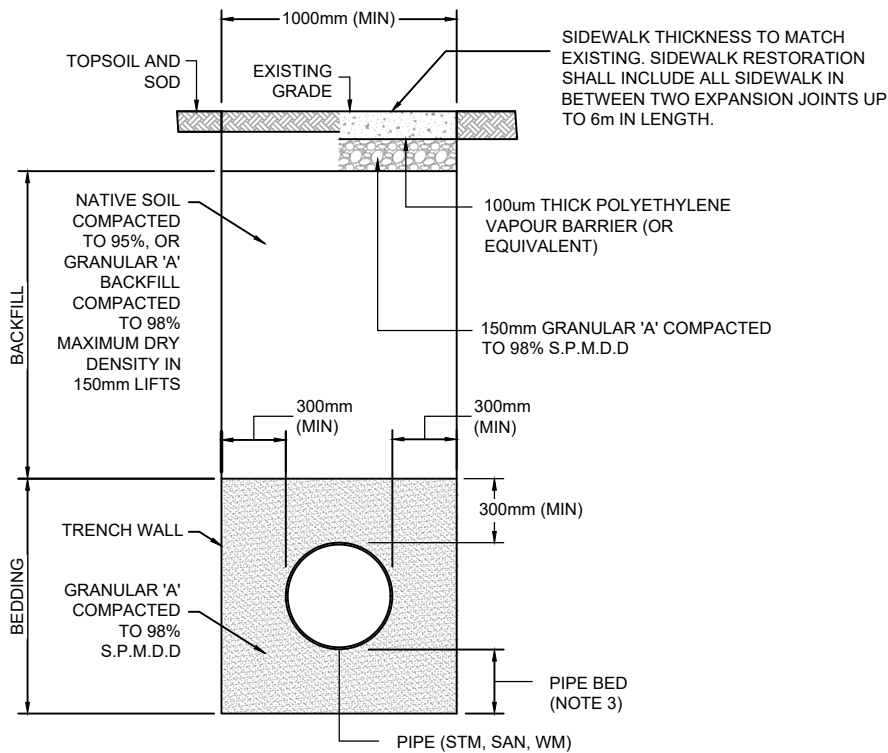

BOULEVARD

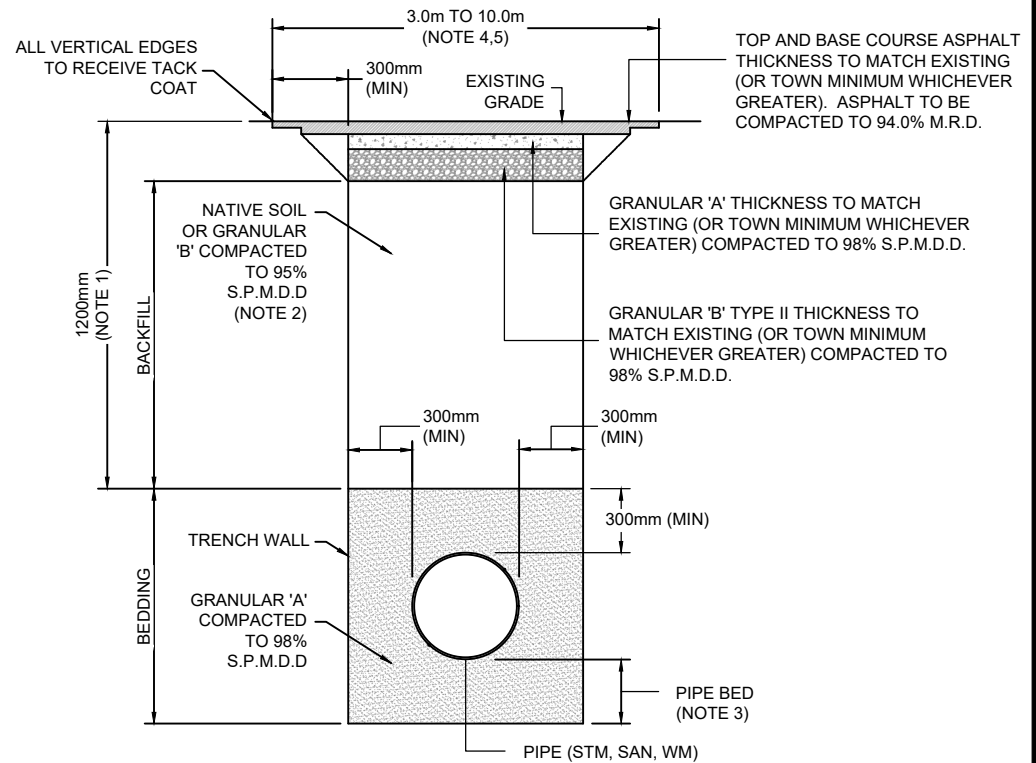

ROADWAY

NOTES:

1. FROST TAPER USED IF DEPTH IS LESS THAN 1200mm
2. UNSHRINKABLE FILL TO BE USED IN INTERSECTIONS AND ON HIGH VOLUME ARTERIAL/COLLECTOR ROADS.
3. REFER TO TOWN OF TILLSONBURG DEVELOPMENT GUIDELINES AND DESIGN CRITERIA FOR APPLICABLE BEDDING REQUIREMENTS FOR LINEAR INFRASTRUCTURE OF FOCUS.
4. 3.0m (MIN) FOR LONGITUDINAL, 10.0m + TRENCH WIDTH (MIN) FOR TRANSVERSE RESTORATION.
5. IF TRENCH TO FACE OF CURB IS LESS THAN 1000mm, FULL DEPTH ASPHALT IS TO BE REMOVED.
6. ALL DIMENSIONS SHOWN IN MILLIMETRES UNLESS OTHERWISE NOTED.



STANDARD DETAIL

TYPICAL TRENCH RESTORATION

APPROVED

MANAGER OF ENGINEERING DATE
 DIRECTOR OF OPERATIONS DATE

REVISION No. DATE: MARCH 2020
 SCALE: N.T.S.

TSD-740

1. GRADE AND CROSSFALL ADJUSTMENT OF MAINTENANCE HOLE AND CATCHBASIN FRAMES WILL BE MADE USING PRODUCTS SPECIFICALLY MANUFACTURED FOR THAT PURPOSE.
2. ADJUSTMENT UNITS MUST BE CERTIFIED TO MEET ALL PERTINENT OPS, CSA, ASTM AND MTO-DSM LISTS, OR OTHER INDUSTRY GUIDELINES FOR MATERIALS, PERFORMANCE AND USE AS APPLICABLE.
3. ADJUSTMENT UNITS AND JOINTS WILL BE SEALED AND OR PARGED IN COMPLIANCE WITH MANUFACTURERS SPECIFICATIONS AND GUIDELINES
4. MORTAR IS USED FOR LEVELING OF PRECAST UNITS ONLY. THE THICKNESS OF MORTAR WILL BE 10mm TO FILL ALL VOIDS CREATED BY IRREGULARITIES IN THE PRECAST UNITS TO ENSURE AN EVEN SURFACE ONLY.



STANDARD DETAIL

GENERAL NOTES FOR ROADWORKS

APPROVED

.....
 MANAGER OF ENGINEERING DATE

 DIRECTOR OF OPERATIONS DATE

REVISION No.	DATE: MARCH 2020
	SCALE: N.T.S.

TSD-750

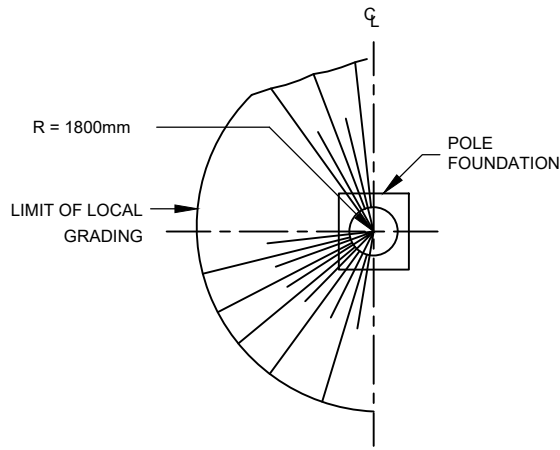

TYPICAL PLAN

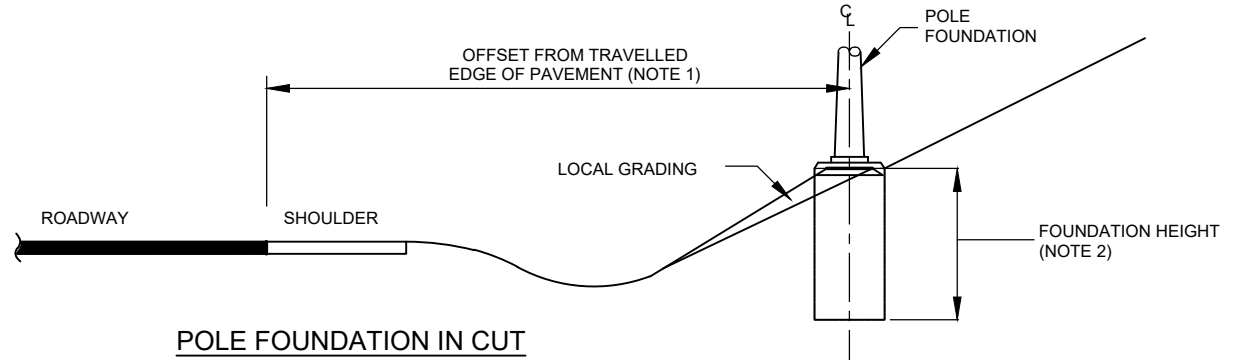

POLE FOUNDATION IN CUT

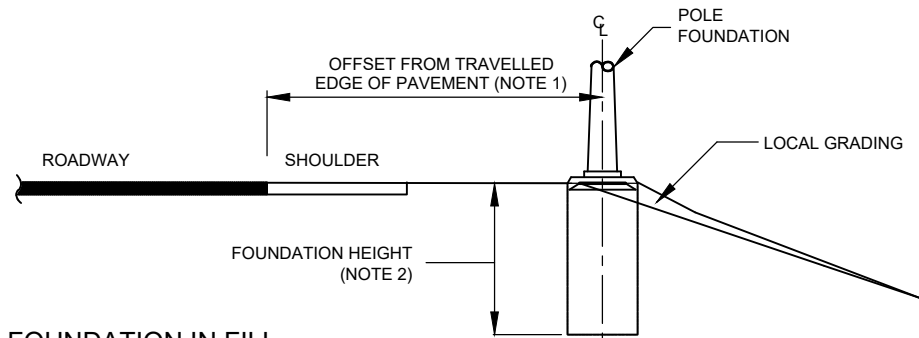

POLE FOUNDATION IN FILL

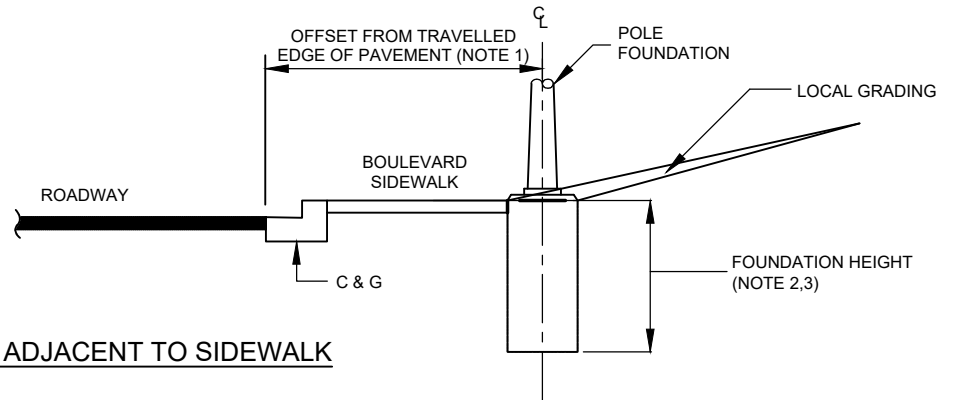

POLE FOUNDATION ADJACENT TO SIDEWALK

NOTES:

1. FOR OFFSET AND POLE TYPE, SEE CONTRACT DRAWINGS.
2. TOP OF FOUNDATION SHALL BE MEASURED FROM THE HIGHEST GRADE ELEVATION.
3. TOP OF FOUNDATION TO BE AT GRADE WITHIN 300mm OF SIDEWALK.
4. ALL DIMENSIONS ARE IN MILLIMETRES OR METRES UNLESS OTHERWISE SHOWN.



STANDARD DETAIL

LOCAL GRADING AT POLE FOUNDATIONS

APPROVED

MANAGER OF ENGINEERING DATE
 DIRECTOR OF OPERATIONS DATE

REVISION No. DATE: DEC 2021
 SCALE: N.T.S.

TSD-801

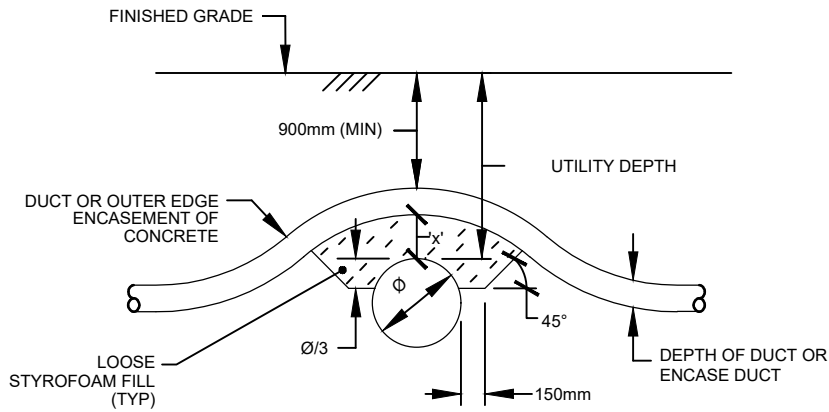

CROSSING OVER UTILITY

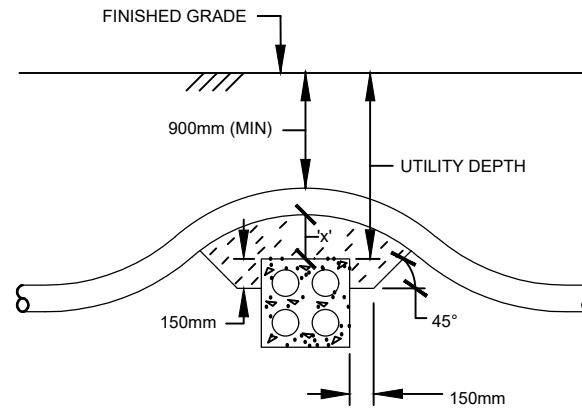

CROSSING OVER CONCRETE ENCASED UTILITY

NOTES:

1. TRENCH WIDTHS AS PER OCCUPATIONAL HEALTH AND SAFETY ACT. UTILITY SUPPORTED IN PLACE WHERE REQUIRED.
2. ALL DIMENSIONS ARE IN MILLIMETRES UNLESS OTHERWISE SHOWN.
3. THE REQUIRED MINIMUM CLEARANCE 'X' BETWEEN THE UTILITY AND THE DUCTS OR CONCRETE ENCASEMENT IS:

DUCTS (DIRECT BURIED OR ENCASED)	100mm
ALL OTHER PIPES	500mm
HIGH VOLTAGE CABLES	1000mm
ALL OTHER CABLES	300mm

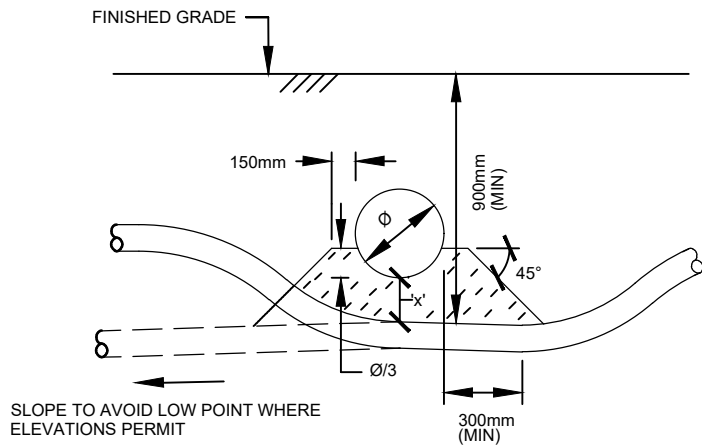

CROSSING UNDER UTILITY

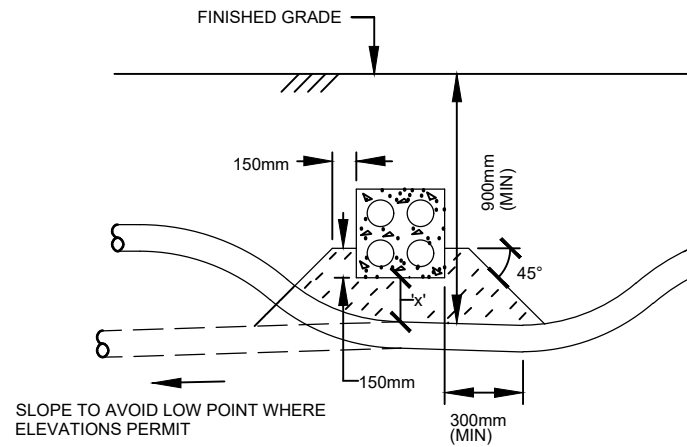

CROSSING UNDER CONCRETE ENCASED UTILITY



STANDARD DETAIL

ROADWAY LIGHTING DUCT INSTALLATION AT UTILITY CROSSING

APPROVED

MANAGER OF ENGINEERING DATE
DIRECTOR OF OPERATIONS DATE

REVISION No. DATE: DEC 2021
SCALE: N.T.S.

TSD-900

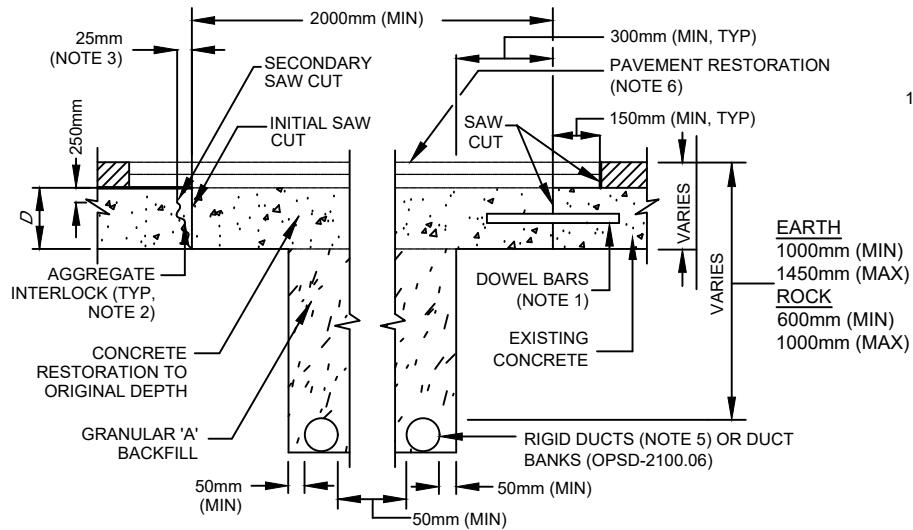

UNDOWELLED TREATMENT (NOTE 2) DOWELLED TREATMENT (NOTE 1)
COMPOSITE OR CONCRETE PAVEMENT

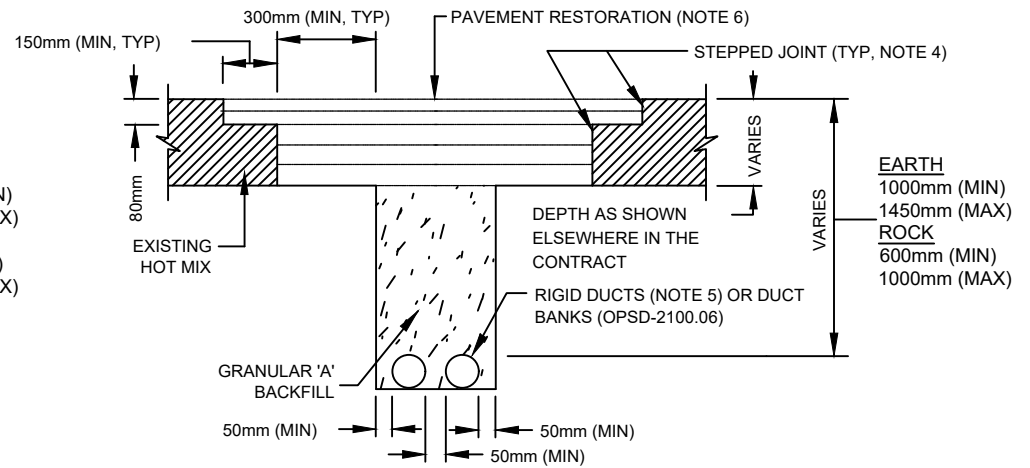

BITUMINOUS PAVEMENT

NOTES:

1. DOWELLED TREATMENT IS ONLY REQUIRED IN EXISTING CONCRETE PAVEMENT OR CONCRETE BASE WHICH CONTAIN LOAD TRANSFER DEVICES. DOWELS SHALL BE 32mm DIA, 450mm LONG, EPOXY COATED, INSTALLED AT 300mm INTERVALS AT MID DEPTH OF THE CONCRETE SLAB, IN PLANE TO THE PAVEMENT SURFACE, PARALLEL TO THE CENTRE LINE OF THE ROAD AND SET 225mm IN 35mm HOLES WITH EPOXY GROUT.
2. UNDOWELLED TREATMENT IS ONLY REQUIRED IN EXISTING CONCRETE PAVEMENT OR CONCRETE BASE WHICH IS CONSTRUCTED WITHOUT LOAD TRANSFER DEVICES AT JOINTS. AGGREGATE INTERLOCK IS CREATED BY CHIPPING THE VERTICAL CONCRETE FACE WITH A LIGHT 15kg MAXIMUM PNEUMATIC HAMMER.
3. THE INITIAL SAW CUT SHALL BE FULL DEPTH. THE SECONDARY SAW CUT SHALL BE 1/4 OF EXISTING PAVEMENT DEPTH WITH 25mm OF CHIPPING FOR AGGREGATE INTERLOCK.
4. WHERE EXISTING PAVEMENT DEPTH IS BETWEEN 80mm AND 120mm, THE 150mm WIDE STEPPED JOINT SHALL BE 40mm DEEP. BITUMINOUS PAVEMENT RESTORATION TO MATCH EXISTING TYPE UNLESS OTHERWISE SPECIFIED. THE SURFACE AND TOP BINDER COURSES SHALL BE PLACED IN 40mm LIFTS, WITH OTHER LIFTS PLACED AT 80mm MAXIMUM.
6. ALL VOIDS BELOW THE PAVEMENT STRUCTURE TO BE REINSTATED AS PER TSD's.
7. ALL DIMENSIONS ARE IN MILLIMETRES UNLESS OTHERWISE SHOWN.



STANDARD DETAIL

ROADWAY LIGHTING DUCT
INSTALLATION IN EXISTING
PAVED AREA

APPROVED

.....
MANAGER OF ENGINEERING DATE

.....
DIRECTOR OF OPERATIONS DATE

REVISION No. DATE: DEC 2021

SCALE: N.T.S.

TSD-901

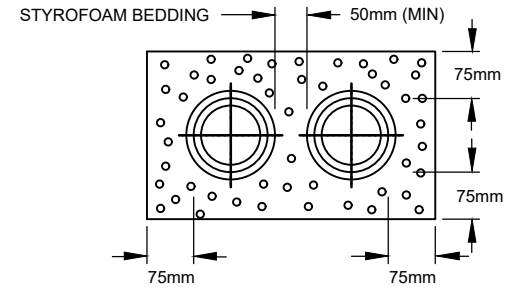
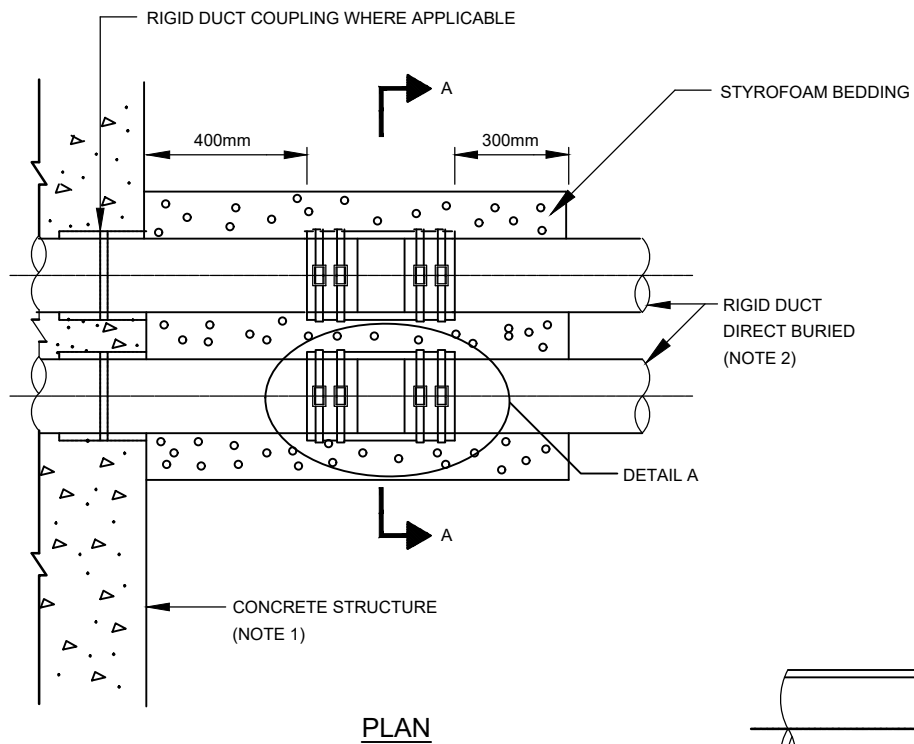

SECTION A-A

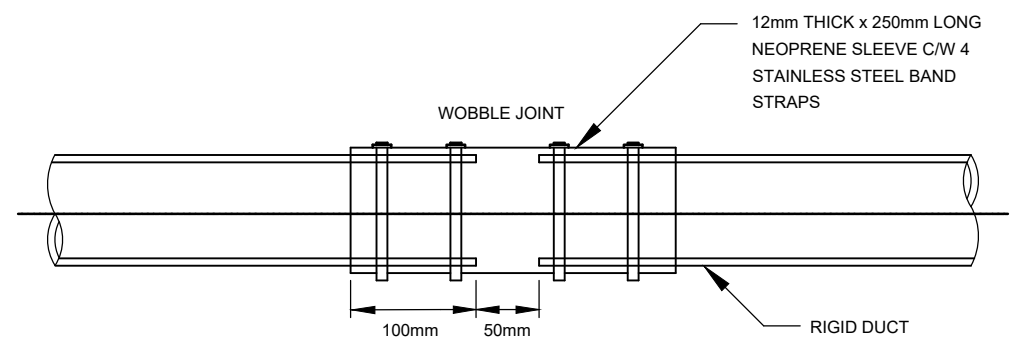

DETAIL A

NOTES:

1. CONCRETE STRUCTURES INCLUDE BRIDGE STRUCTURE, CONCRETE FOOTING, ELECTRICAL MAINTENANCE HOLE, CONCRETE DUCT BANK, CONCRETE VAULT, ETC.
2. FOR NUMBER, SIZES AND ORIENTATION OF DUCTS REFER TO CONTRACT DRAWINGS.
3. ALL DIMENSIONS ARE IN MILLIMETRES UNLESS OTHERWISE SHOWN.



STANDARD DETAIL

UNDERGROUND RIGID DUCT CONNECTION AT CONCRETE STRUCTURE

APPROVED

MANAGER OF ENGINEERING DATE
 DIRECTOR OF OPERATIONS DATE

REVISION No. DATE: MARCH 2020
 SCALE: N.T.S.

TSD-902

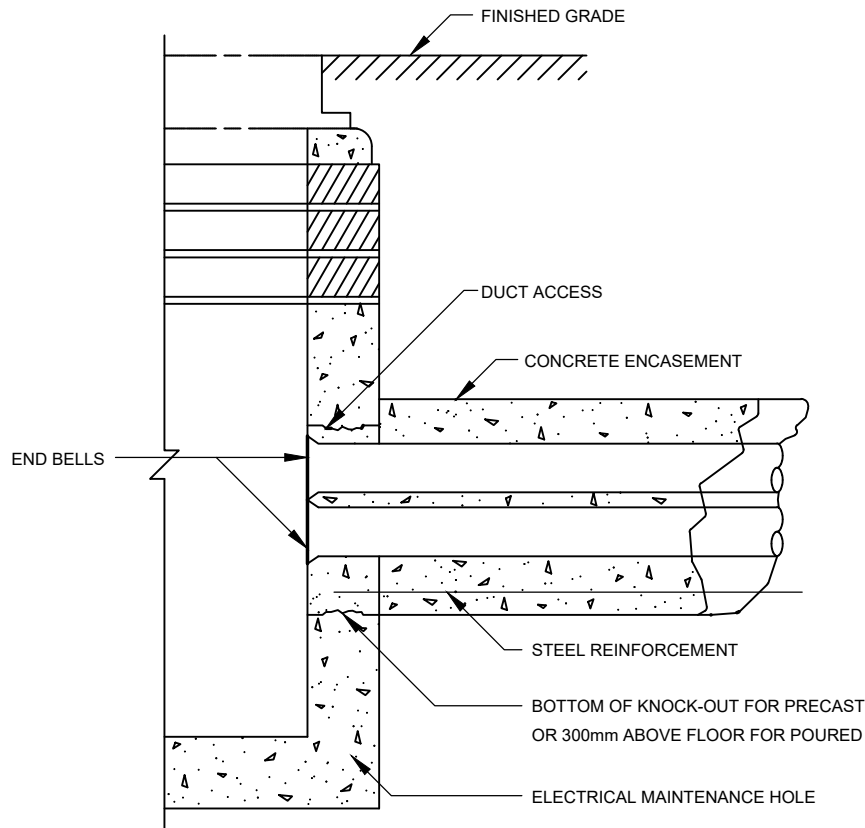

CONCRETE ENCASED RIGID DUCTS

NOTES:

1. GROUT TO BE PLACED FULL DEPTH, FLUSH WITH BOTH WALLS.
2. GROUT TO BE PLACED WITHIN STEEL PIPE, AROUND ALL DUCTS, TO A MINIMUM DEPTH OF 75mm.
3. ALL DIMENSIONS ARE IN MILLIMETRES OR METRES UNLESS OTHERWISE SHOWN.



STANDARD DETAIL

ELECTRICAL VAULT ENTRY OF ENCASED DUCTS

APPROVED

MANAGER OF ENGINEERING DATE

DIRECTOR OF OPERATIONS DATE

REVISION No. DATE: MARCH 2020

SCALE: N.T.S.

TSD-903

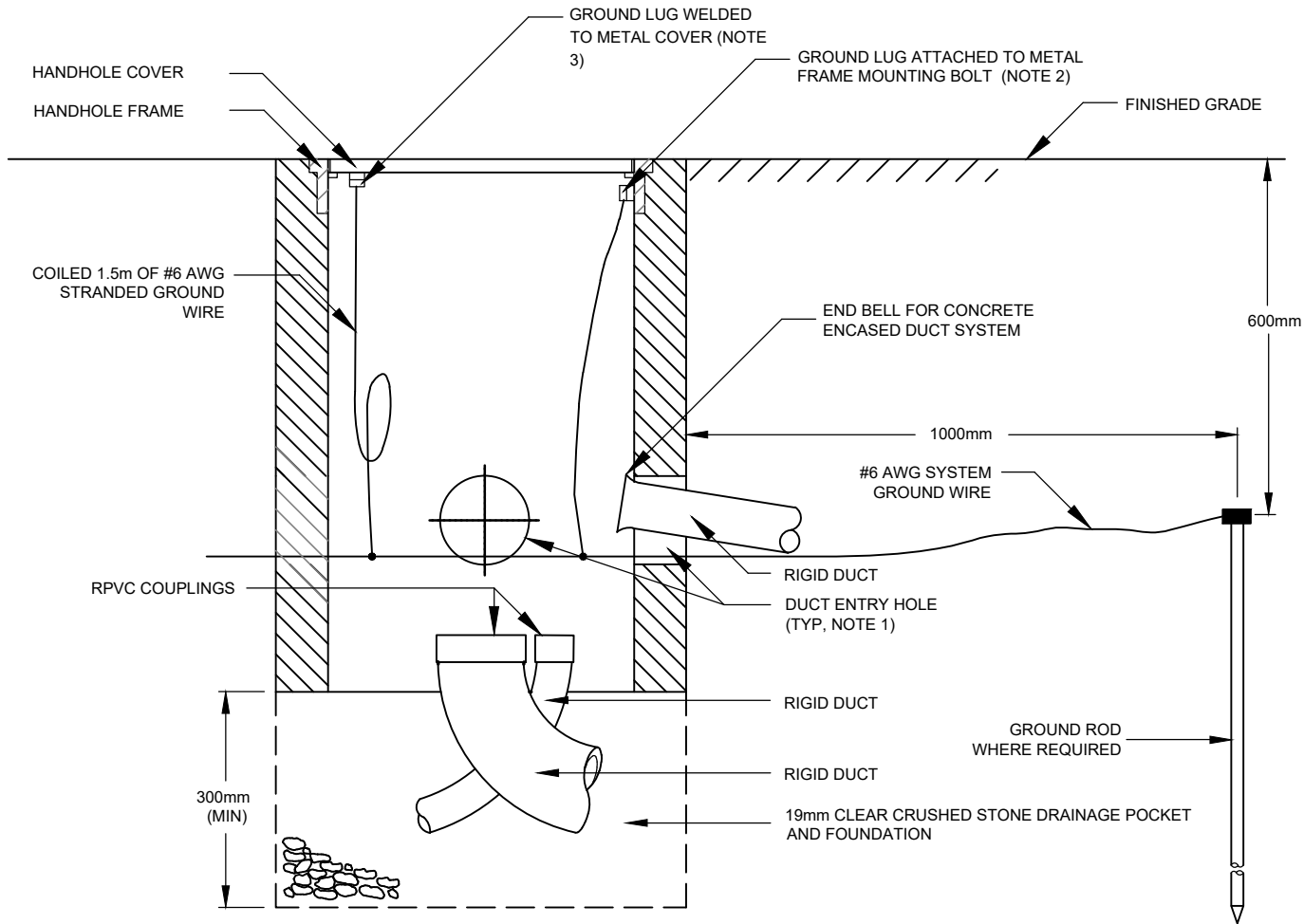

NOTES:

1. FOR DUCT ENTRY DETAILS SEE TSD-905.
2. FOR HANDHOLES WITH METAL FRAMES, GROUND WIRE SHALL BE ATTACHED TO FRAME USING A GROUND LUG SUITABLE FOR #6 AWG STRANDED COPPER WIRE.
3. FOR HANDHOLES WITH METAL COVERS AND NON METALLIC FRAMES, THE GROUND WIRE SHALL BE ATTACHED TO THE HANDHOLE COVER USING A GROUND LUG SUITABLE FOR #6 AWG COPPER WIRE.
4. ALL DIMENSIONS ARE IN MILLIMETRES UNLESS OTHERWISE SHOWN.



STANDARD DETAIL

ELECTRICAL HANDHOLES GENERAL INSTALLATION REQUIREMENTS

APPROVED

MANAGER OF ENGINEERING DATE
DIRECTOR OF OPERATIONS DATE

REVISION No. DATE: MARCH 2020
SCALE: N.T.S.

TSD-904

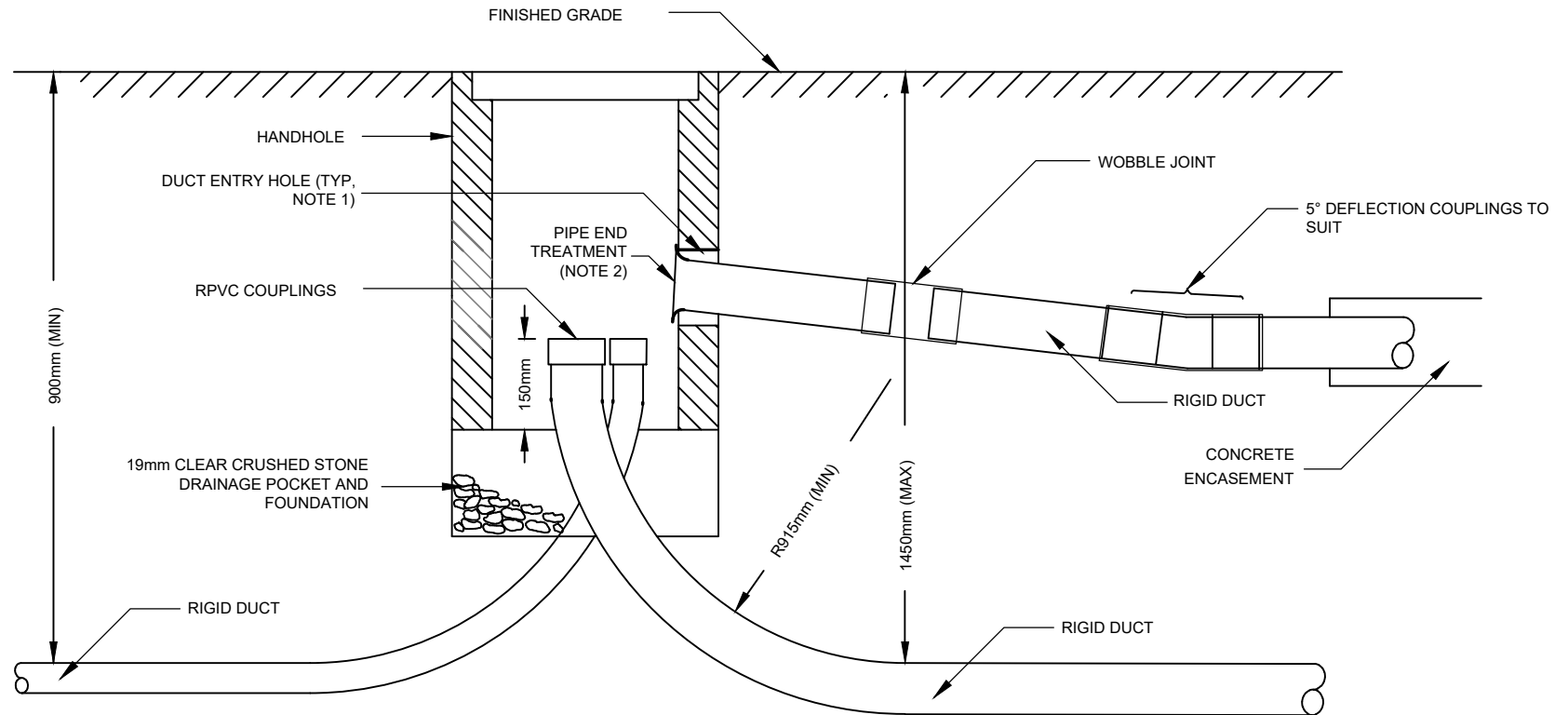

NOTES:

1. DUCT ENTRY HOLES TO BE FILLED WITH GROUT, FULL DEPTH, FLUSH WITH BOTH WALLS.
2. RIGID DUCTS TERMINATING IN MAINTENANCE HOLES, HANDHOLES, OR OTHER PERMANENT OPENINGS OF UNDERGROUND SYSTEMS SHALL BE PROVIDED WITH AN END BELL. RIGID DUCTS ENTERING THE BOTTOM OF HANDHOLES SHALL BE FITTED WITH RPVC COUPLING.
3. ALL DIMENSIONS ARE IN MILLIMETRES UNLESS OTHERWISE SHOWN.



STANDARD DETAIL

ELECTRICAL HANDHOLES ENTRY OF DIRECT BURIED ENCASED DUCTS

APPROVED

MANAGER OF ENGINEERING DATE
DIRECTOR OF OPERATIONS DATE

REVISION No.	DATE: MARCH 2020
	SCALE: N.T.S.

TSD-905

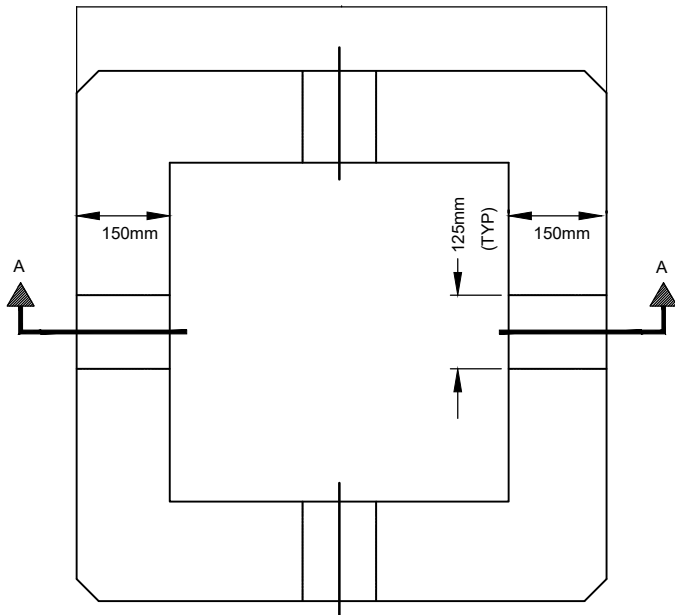

PLAN

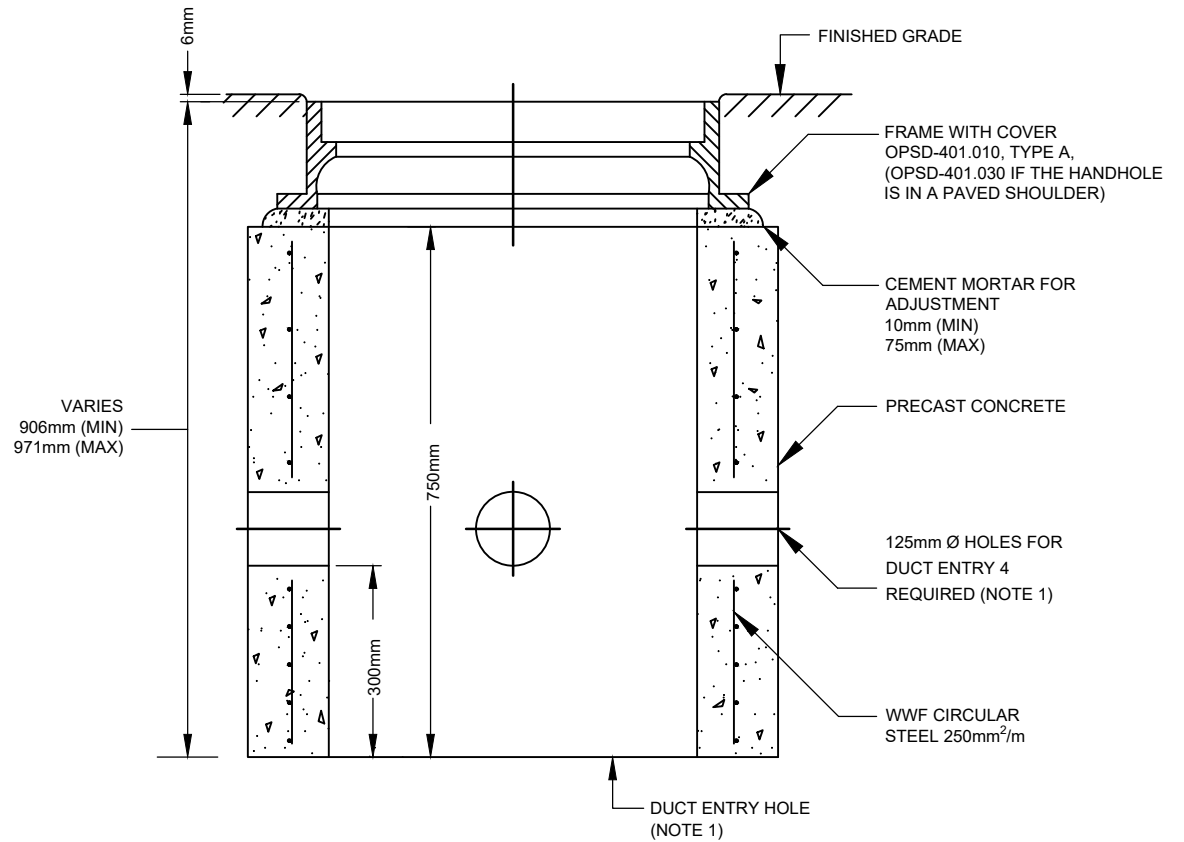

SECTION A-A

NOTES:

1. FOR DUCT INSTALLATION DETAILS SEE TSD-905.
2. FOR GENERAL INSTALLATION DETAILS SEE TSD-904.
3. ALL DIMENSIONS ARE IN MILLIMETRES UNLESS OTHERWISE SHOWN.



STANDARD DETAIL

**ELECTRICAL HANDHOLE
PRECAST CONCRETE
600mm x 600mm**

APPROVED

MANAGER OF ENGINEERING DATE

DIRECTOR OF OPERATIONS DATE

REVISION No. DATE: MARCH 2020

SCALE: N.T.S.

TSD-906

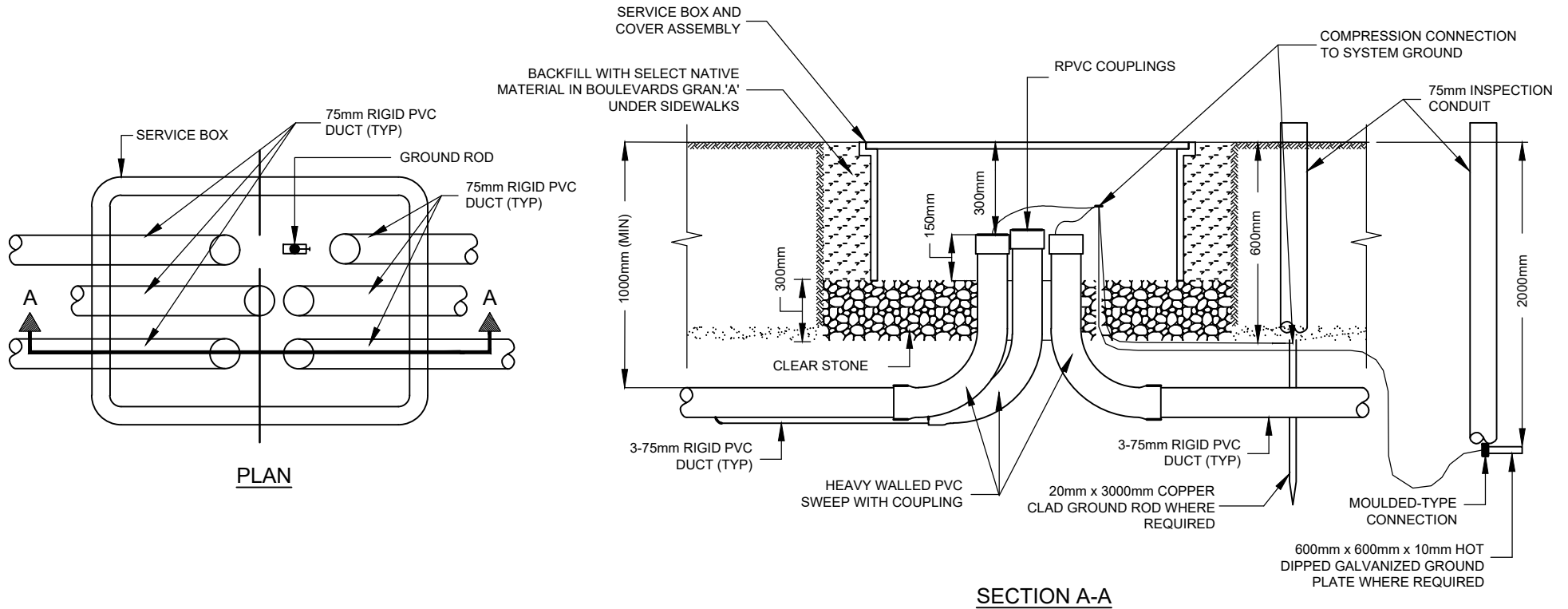

NOTES:

1. TOP OF SERVICE BOX SHALL BE LEVEL TO CONFORM TO FINISHED GRADE.
2. ALL DUCTS USED IN OPEN CUT INSTALLATION TO BE HEAVY WALLED PVC CONDUITS.
3. END OF ALL DUCTS MUST BE TEMPORARILY CAPPED UNTIL WIRES PULLED.
4. BACKFILL UNDER ROAD AND IN ISLAND TO BE GRANULAR 'A' COMPACTED TO 98% SPMD.
5. BACKFILL IN BOULEVARD TO BE SELECTED EXCAVATED MATERIAL AS SPECIFIED IN SPECIFICATIONS.
6. ALL DUCTS MUST BE FREE AND CLEAR OF ALL DEBRIS AND OBSTRUCTIONS (DIRT, STONE, ETC).
7. CONTRACTOR TO SUPPLY AND PLACE 5mm POLYPROPYLENE FISH ROPE IN ALL DUCTS.
8. CONTRACTOR TO SUPPLY AND INSTALL GROUND ROD/PLATE AND CONNECTOR IN ALL NEW SERVICE BOXES WHERE INDICATED IN CONTRACT.
9. END OF ALL DUCTS MUST HAVE RPVC COUPLINGS INSTALLED.
10. 75mm INSPECTION CONDUIT REQUIRED FOR GROUND ROD/PLATE CONNECTION OUTSIDE OF HANDHOLE.
11. SERVICE BOXES AND COVERS SHALL MEET ANSI/SCTE77-2007 TIER 15 LOAD RATING. 11.

SERVICE BOXES & COVERS					
		SYNERTECTH		QUAZITE	
SIZE (mm)		BOX	COVER	BOX	COVER
330X610	TYPE I	S1324B18FA	S1324HBBOA	PT1324BA18	PT1324HAOO46
432X762	TYPE II	S1730B18FA	S1730HBBOA	PT1730BA18	PT1730HAOO46



STANDARD DETAIL

**PREFABRICATED
SERVICE BOX ASSEMBLIES**

APPROVED

MANAGER OF ENGINEERING DATE

DIRECTOR OF OPERATIONS DATE

REVISION No. DATE: MARCH 2020

SCALE: N.T.S.

TSD-907

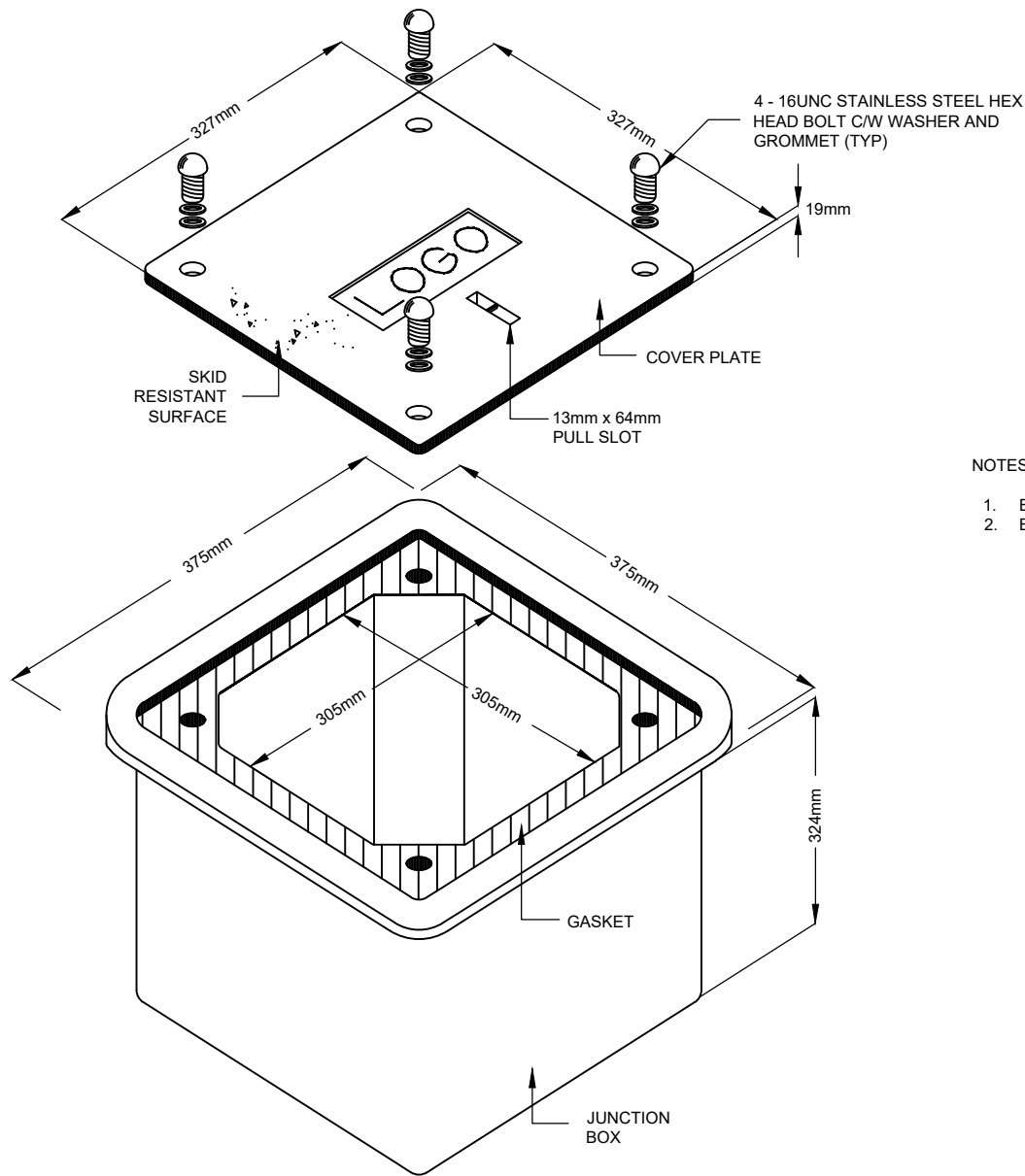

NOTES:

1. BOXES SHALL BE STACKABLE CONCRETE COMPOSITE TYPE ONLY.
2. BOXES AND COVER SHALL MEET ANSI/SCTE 77-2007 TIER 15 LOAD RATING.

BOXES (STACKABLE)	
DESCRIPTION	PART No.
NO Base	PC1212BA12

COVERS (BLACK UNLESS LOGO SPECIFIED)	
DESCRIPTION	PART No.
C/W 4 Bolts	PC1212HA0046



STANDARD DETAIL

TYPICAL LOOP AND STREET LIGHTING JUNCTION BOX

APPROVED

MANAGER OF ENGINEERING DATE

DIRECTOR OF OPERATIONS DATE

REVISION No. DATE: MARCH 2020

SCALE: N.T.S.

TSD-908

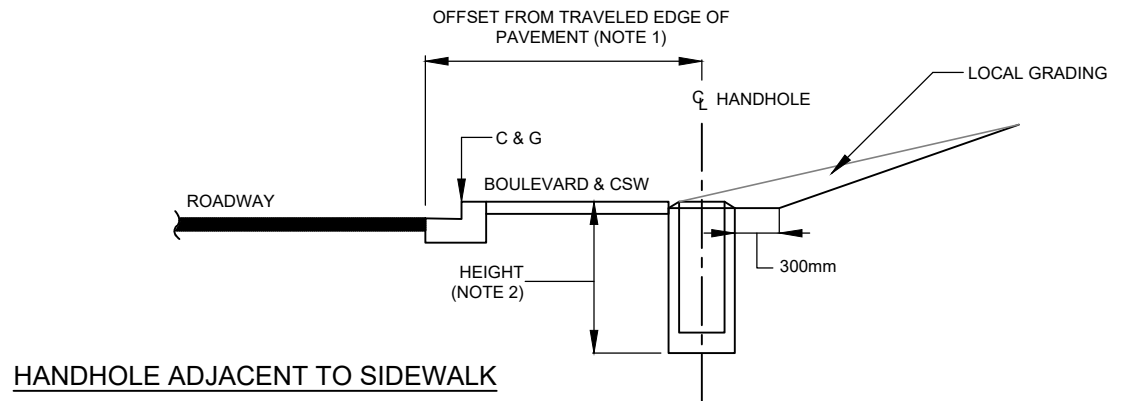
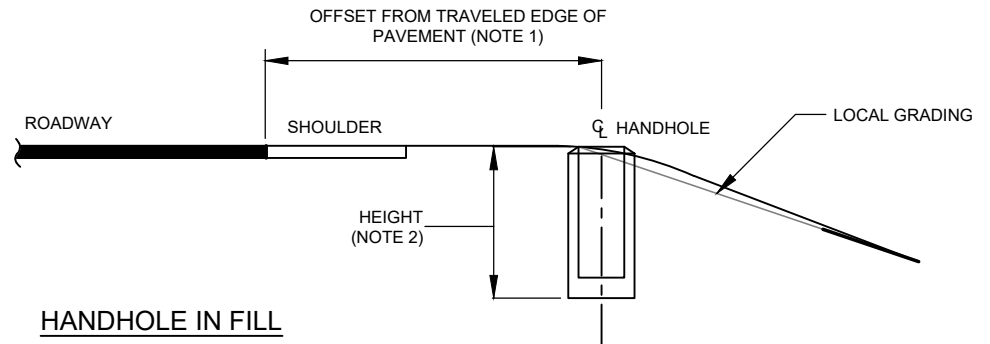
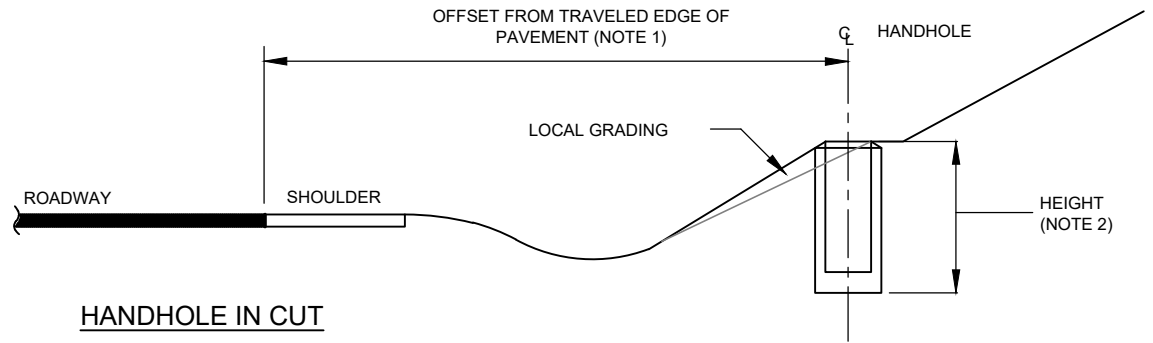
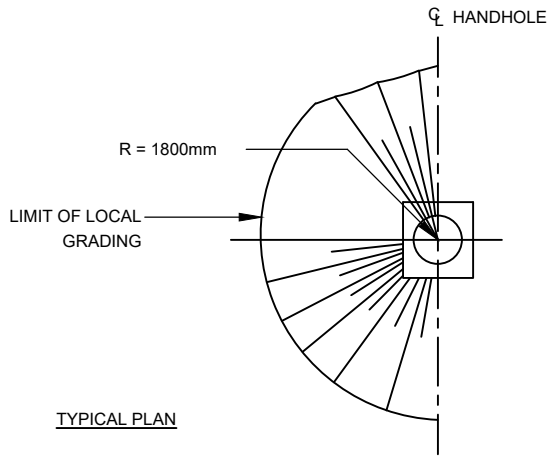

NOTES:

1. FOR OFFSET AND BURIAL DEPTH, SEE CONTRACT DRAWINGS.
2. TOP ELEVATION OF HANDHOLE SHALL BE MEASURED FROM THE HIGHEST GRADE ELEVATION.
3. ALL DIMENSIONS ARE IN MILLIMETRES UNLESS OTHERWISE SHOWN.



STANDARD DETAIL

ELECTRICAL HANDHOLE INSTALLATION IN SLOPE

APPROVED

MANAGER OF ENGINEERING DATE
DIRECTOR OF OPERATIONS DATE

REVISION No. DATE: MARCH 2020
SCALE: N.T.S.

TSD-909

OVERHEAD SERVICES

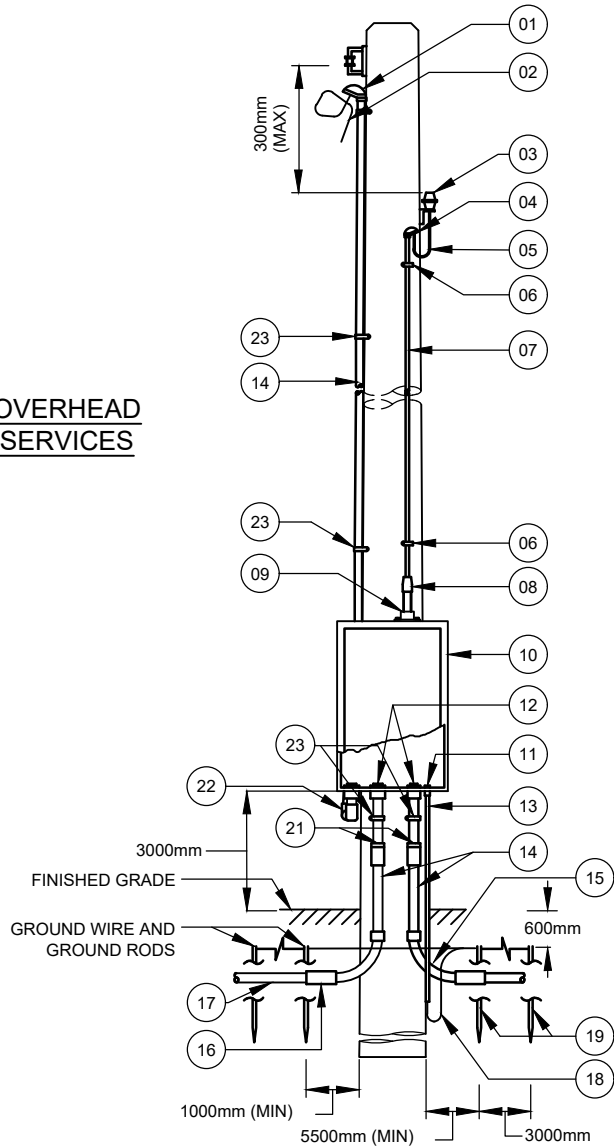

COMPONENT LIST

- 01 SERVICE ENTRANCE FITTING, 50mm, RIGID PVC
- 02 1000mm COIL OF CABLE FOR CONNECTION TO INCOMING SUPPLY
- 03 PHOTOELECTRIC CONTROLLER WITH BRACKET
- 04 SERVICE ENTRANCE FITTING, 25mm, RIGID PVC
- 05 3 NO. 12 AWG, LOW VOLTAGE CABLE
- 06 CLAMP FOR, 25mm, RIGID PVC
- 07 CONDUIT, 25mm, RIGID PVC
- 08 REDUCING ADAPTER, 50mm TO 25mm, RIGID PVC
- 09 METER HUB, 50mm, RIGID PVC
- 10 SUPPLY CONTROL CABINET
- 11 TERMINAL ADAPTER AND LOCKNUT, 20mm, RIGID PVC
- 12 TERMINAL ADAPTER AND LOCKNUT, 50mm, RIGID PVC
- 13 CONDUIT, 20mm, RIGID PVC
- 14 CONDUIT, 50mm, RIGID PVC
- 15 STANDARD 90° ELBOW, 50MM, RIGID PVC
- 16 ADAPTER COUPLING, 50mm
- 17 CONDUIT, 50mm, POLYETHYLENE OR STEEL AS INDICATED
- 18 GROUND WIRE, NOTE 1
- 19 GROUND ROD, NOTE 1
- 20 METER BASE, 100A, 600V
- 21 EXPANSION COUPLING.
- 22 ACCESS FITTING TYPE LB, 50mm RIGID PVC
- 23 CLAMP FOR, 50mm, RIGID PVC

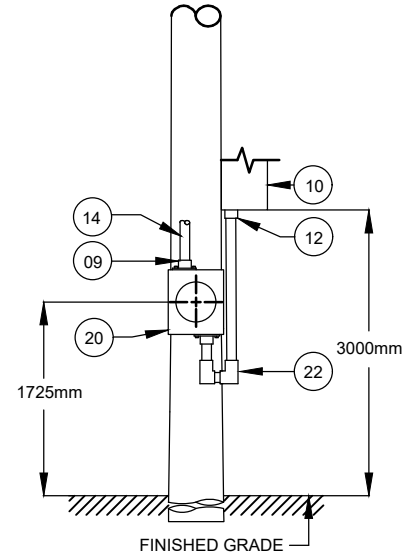

DETAIL OF METER BASE

NOTES:

1. NUMBER OF GROUND RODS AND SIZE OF GROUND WIRE SHALL BE AS INDICATED IN THE CONTRACT.
2. THE METER BASE (IF REQUIRED) SHALL BE BONDED IN CONFORMANCE WITH THE REQUIREMENTS OF THE ELECTRICAL SAFETY AUTHORITY. METER BASE SHALL BE PLACED ON THE SIDE OF THE POLE THAT IS MOST ACCESSIBLE TO THE SUPPLY AUTHORITY.
3. ALL DIMENSIONS ARE IN MILLIMETRES UNLESS OTHERWISE SHOWN.



STANDARD DETAIL

**SUPPLY CONTROL CABINET
INSTALLATION OVERHEAD
SERVICES BOTTOM ENTRY**

APPROVED

.....
MANAGER OF ENGINEERING DATE
.....
DIRECTOR OF OPERATIONS DATE

REVISION No. DATE: MARCH 2020
SCALE: N.T.S.

TSD-910

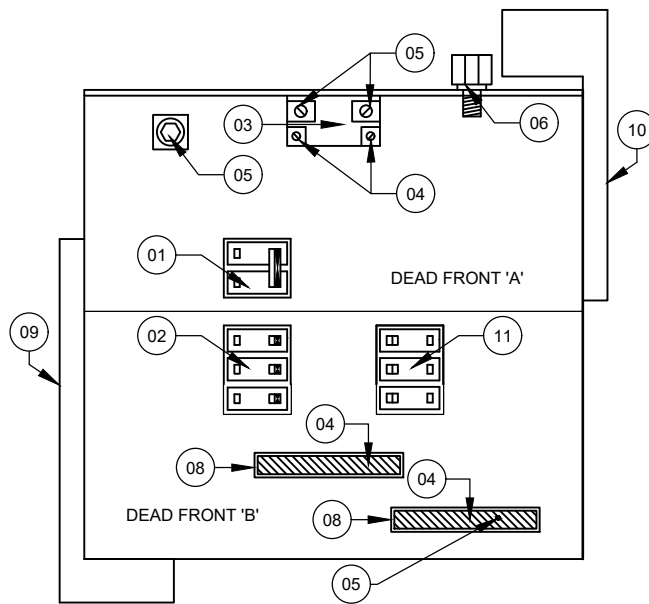



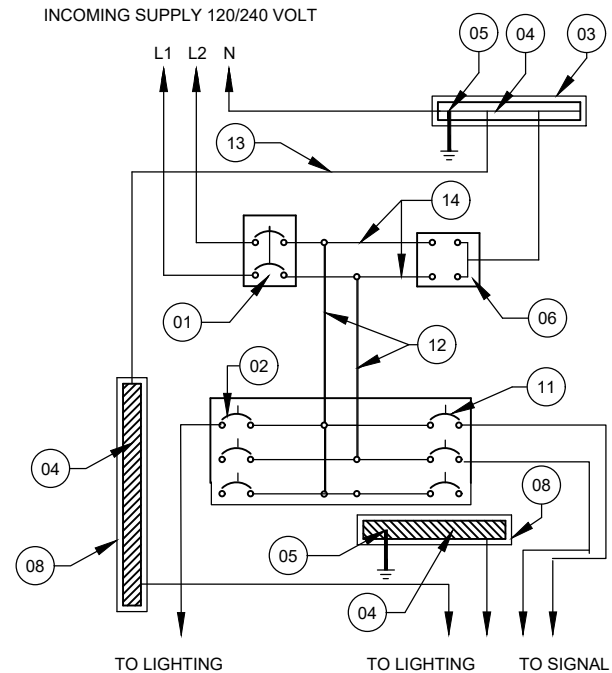

EQUIPMENT LAYOUT



SCHEMATIC WIRING DIAGRAM

LEGEND

-  DENOTES TERMINAL CONNECTION.
-  DENOTES #6 AWG RWU90 WIRE.
-  DENOTES #12 AWG RWU90 WIRE.
-  DENOTES FIELD WIRING (SIZES ARE INDICATED ELSEWHERE ON THE CONTRACT DRAWINGS).
-  GROUND LINK.

ELECTRICAL EQUIPMENT LIST

- 01 MAIN CIRCUIT BREAKER, 240V, 100A, 2-POLE.
- 02 BRANCH CIRCUIT BREAKERS, 120/240V, 35A, 1-POLE.
- 03 SOLID NEUTRAL ASSEMBLY, 100A MIN. AMPACITY.
- 04 GROUND LUG FOR #6 AWG STRANDED COPPER GROUND WIRE.
- 05 GROUND LUG FOR #2/0 AWG STRANDED COPPER GROUND WIRE.
- 06 SECONDARY LIGHTNING ARRESTER, 650V, 2-POLE.
- 07 DRIP SHIELD.
- 08 LOCATE SECONDARY NEUTRAL AND GROUND BARS ACCORDING TO CSA AND PROJECT REQUIREMENTS.
- 09 PRIMARY BARRIER.
- 10 SECONDARY BARRIER.
- 11 BRANCH BREAKER, 240V, 60A, 1 POLE.
- 12 COPPER BUS BAR.
- 13 #6 AWG RWU90 WIRE.
- 14 #12 AWG RWU90 WIRE.



STANDARD DETAIL

**LS3M SUPPLY CONTROL CABINET
ASSEMBLY TYPE 3M 120/240V,
100A, 1-PHASE, 3-WIRE**

APPROVED

MANAGER OF ENGINEERING DATE
DIRECTOR OF OPERATIONS DATE

REVISION No. DATE: MARCH 2020
SCALE: N.T.S.

TSD-911

BILL OF MATERIALS				
ITEM NO.	QTY.	DESCRIPTION	MANUFACTURER	PART NO.
01	1	MAIN BREAKER 100A 2P	SQ.D	QO2100
02	5	BRANCH BREAKERS 35A 1POLE	SQ.D	QO135
11	1	BRANCH BREAKER 60A 1 POLE	SQ.D	QO160
03	1	SOLID NEUTRAL ASSEMBLY 100A MIN.	SQ.D	CH200SN
04	1	GROUND LUG FOR #6 COPPER WIRE		
05	1	GROUND LUG FOR #2/0 COPPER	T&B	ADR 25-21
06	1	SECONDARY LIGHTING ARRESTER	GE	9L15ECB001
07	1	DRIP SHIELD	B&M	CUSTOM

NOTES:

1. TYPE 3M NAMEPLATE SEE DETAIL BELOW.
2. PANEL IS SERVICE ENTRANCE READY.

(MANUFACTURER) TYPE 3M 100 AMP 120/240 VOLT (DATE OF MANUFACTURE)
--

NAMEPLATE SAMPLE



STANDARD DETAIL

LS3M SUPPLY CONTROL
 CABINET ASSEMBLY TYPE 3M
 EQUIPMENT LIST

APPROVED

.....
 MANAGER OF ENGINEERING DATE

 DIRECTOR OF OPERATIONS DATE

REVISION No.	DATE: MARCH 2020
	SCALE: N.T.S.

TSD-912

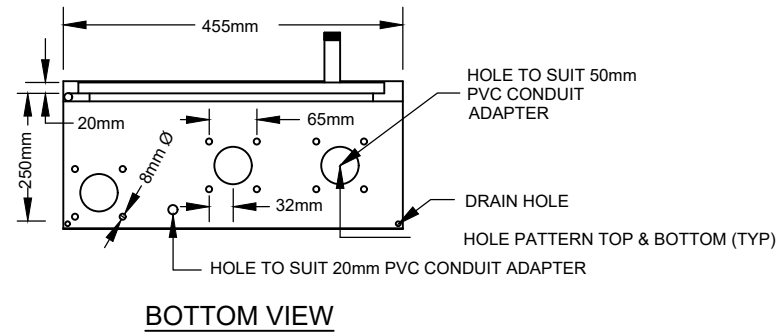
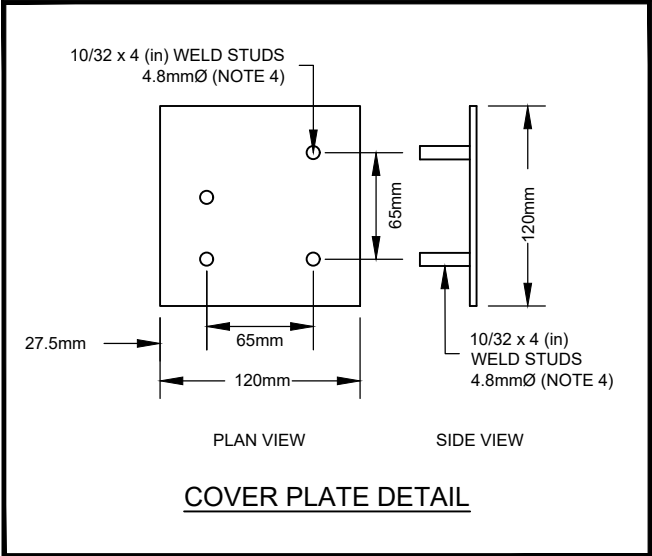
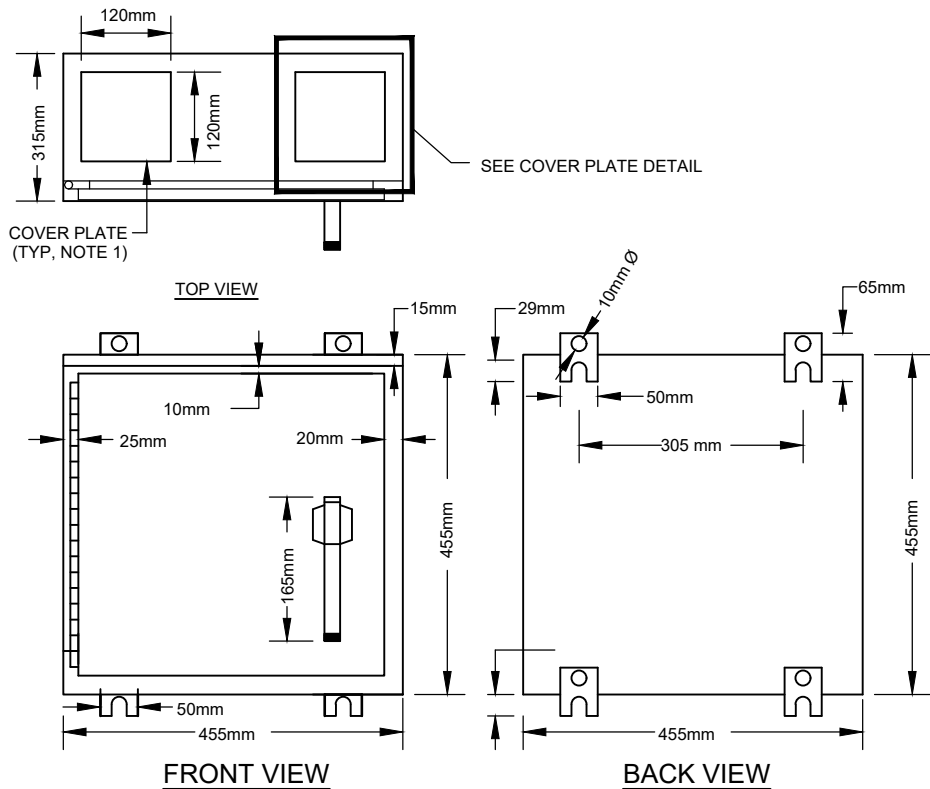

NOTES:

1. ALL PLATES SHALL BE THE SAME SIZE.
2. BOLT AND HOLE PATTERN TO SUIT METER HUB.
3. GROUND STUD SHALL BE COMPLETE WITH WASHERS AND NUTS.
4. COVER PLATE STUDS SHALL BE COMPLETE WITH WASHERS AND NUTS.
5. ALL DIMENSIONS ARE IN MILLIMETRES WITH TOLERANCES $\pm 3\text{mm}$ UNLESS OTHERWISE SHOWN.



STANDARD DETAIL

**LS3M SUPPLY CONTROL
CABINET ASSEMBLY TYPE 3M
ENCLOSURE**

APPROVED

MANAGER OF ENGINEERING DATE
DIRECTOR OF OPERATIONS DATE

REVISION No. DATE: MARCH 2020
SCALE: N.T.S.

TSD-913

DEAD FRONT A

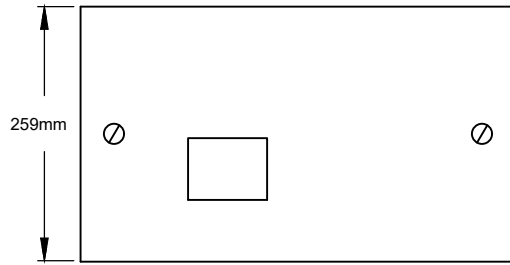

FRONT VIEW

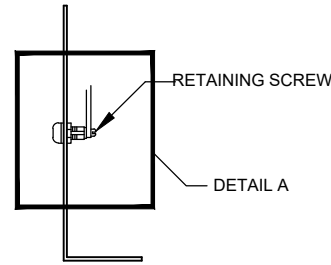

SIDE VIEW

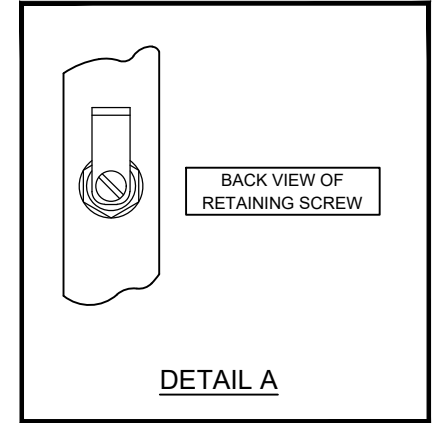

DETAIL A

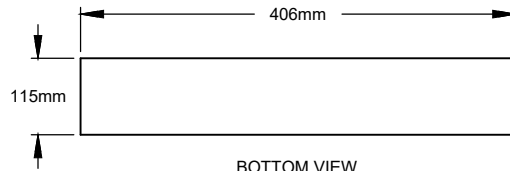

BOTTOM VIEW

DEAD FRONT B

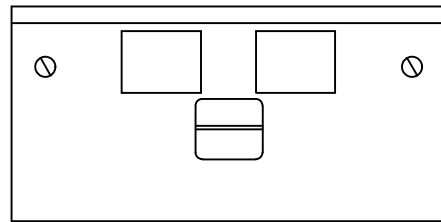

FRONT VIEW

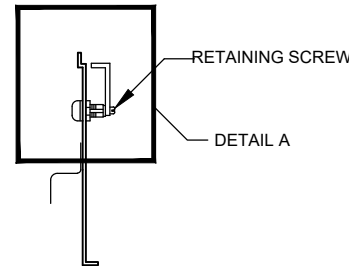

SIDE VIEW

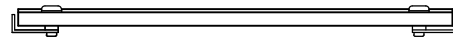

BOTTOM VIEW

NOTES:

1. ALL DIMENSIONS ARE IN MILLIMETRES WITH TOLERANCES ± 3 mm UNLESS OTHERWISE SHOWN.



STANDARD DETAIL

LS3M SUPPLY CONTROL
CABINET ASSEMBLY TYPE 3M
DEAD FRONT PANEL

APPROVED

MANAGER OF ENGINEERING DATE
DIRECTOR OF OPERATIONS DATE

REVISION No. DATE: MARCH 2020
SCALE: N.T.S.

TSD-914

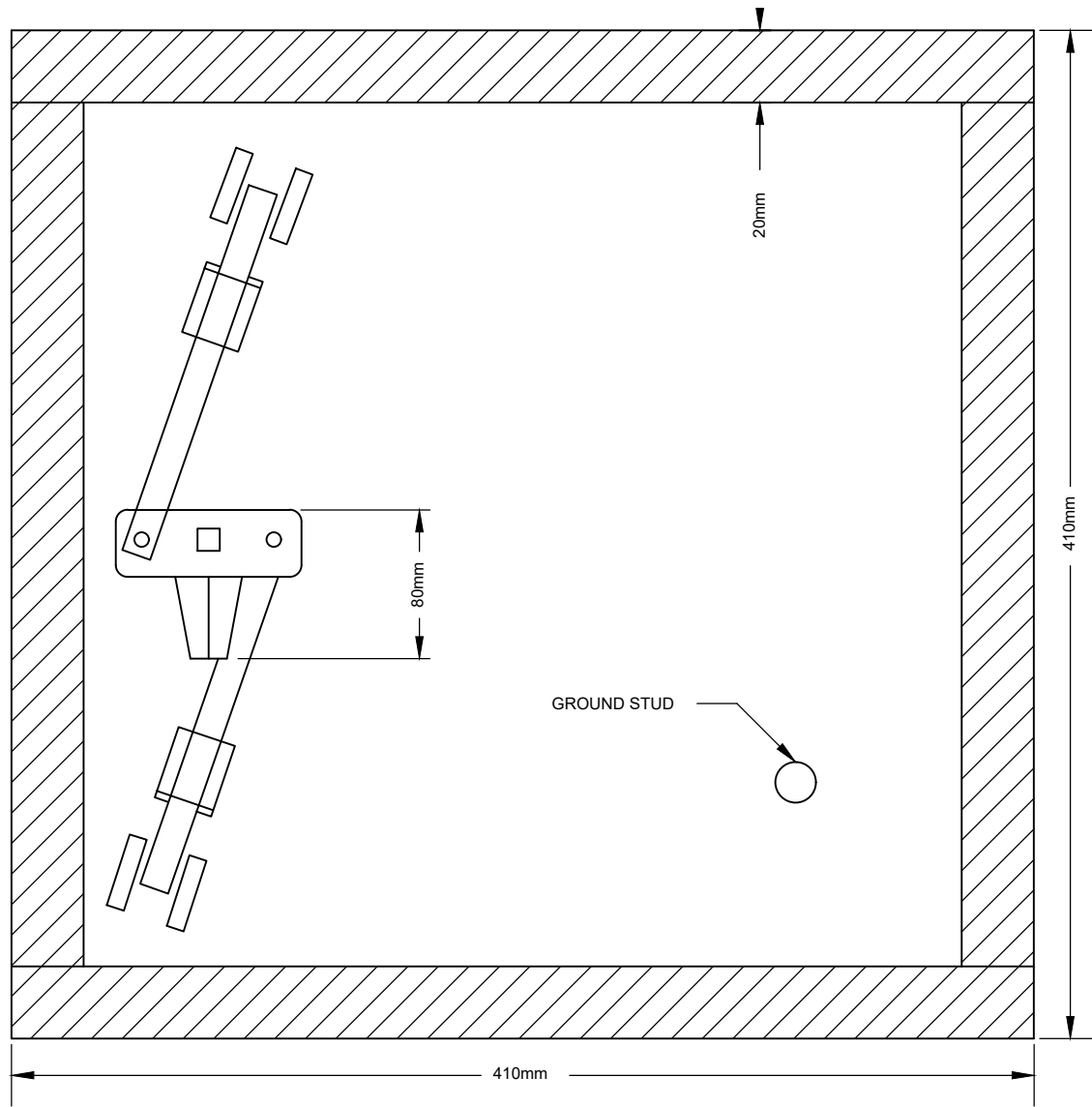

NOTES:

1. ALL DIMENSIONS ARE IN MILLIMETRES WITH TOLERANCES $\pm 3\text{mm}$ UNLESS OTHERWISE SHOWN.



STANDARD DETAIL

**LS3M SUPPLY CONTROL
CABINET ASSEMBLY TYPE 3M
DEAD DOOR LATCH**

APPROVED

MANAGER OF ENGINEERING DATE
DIRECTOR OF OPERATIONS DATE

REVISION No.	DATE: MARCH 2020
	SCALE: N.T.S.

TSD-915

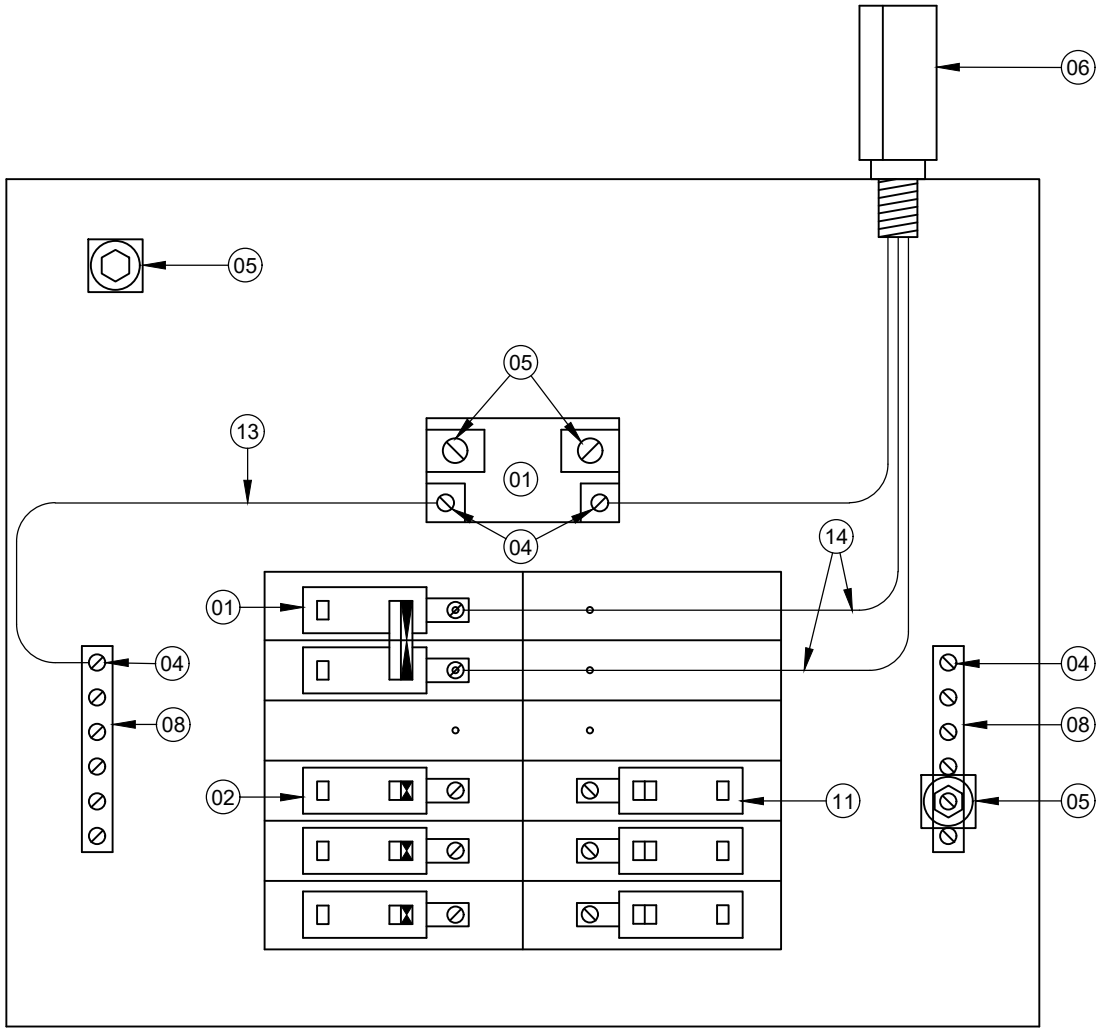

ELECTRICAL EQUIPMENT LIST

- 01 MAIN CIRCUIT BREAKER, 240V, 100A, 2-POLE.
- 02 BRANCH CIRCUIT BREAKERS, 120/240V, 35A, 1-POLE.
- 04 GROUND LUG FOR #6 AWG STRANDED COPPER GROUND WIRE.
- 05 GROUND LUG FOR #2/0 AWG STRANDED COPPER GROUND WIRE.
- 06 SECONDARY LIGHTNING ARRESTER, 650V, 2-POLE.
- 08 LOCATE SECONDARY NEUTRAL AND GROUND BARS ACCORDING TO CSA AND PROJECT REQUIREMENTS..
- 11 BRANCH BREAKER, 240V, 60A, 1 POLE.
- 13 #6 AWG RWU90 WIRE.
- 14 #12 AWG RWU90 WIRE.



STANDARD DETAIL

LS3M SUPPLY CONTROL
CABINET ASSEMBLY TYPE 3M
INSTRUMENT LAYOUT

APPROVED

MANAGER OF ENGINEERING DATE
DIRECTOR OF OPERATIONS DATE

REVISION No. DATE: MARCH 2020
SCALE: N.T.S.

TSD-916

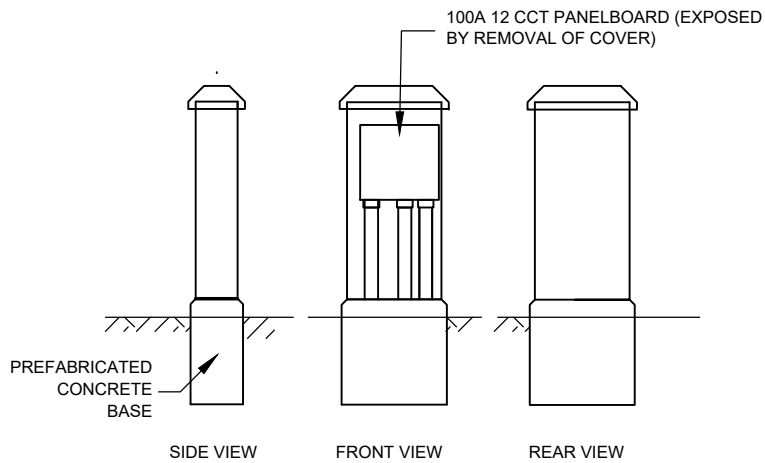

42" PEDESTAL

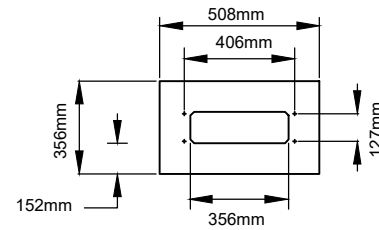

TOP VIEW

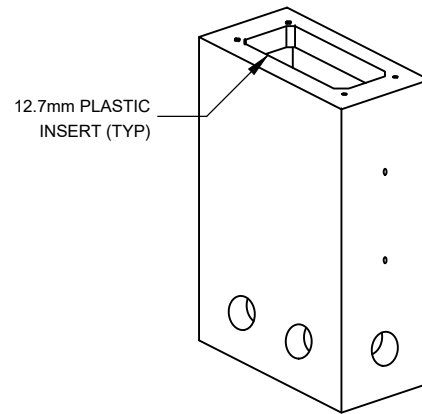

ISOMETRIC VIEW

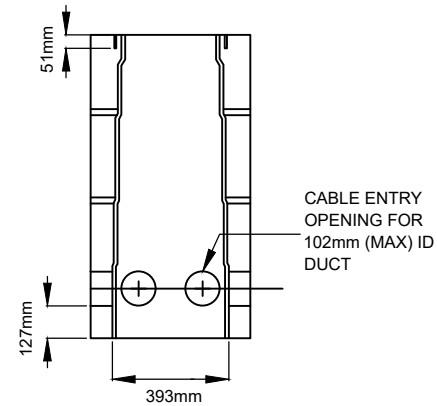

FRONT VIEW

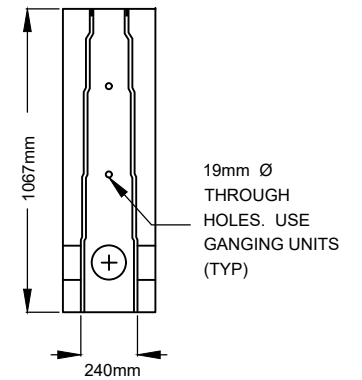

SIDE VIEW

CONCRETE BASE

NOTES:

1. POWER SUPPLY PEDESTAL ASSEMBLY (PEDESTAL SOLUTIONS INC.) OR APPROVED EQUIVALENT.
2. PREFABRICATED CONCRETE BASE (BY BROOKLYN CONCRETE, MODEL BCP 20PED) OR APPROVED EQUIVALENT.
3. ALL DIMENSIONS ARE IN MILLIMETRES UNLESS OTHERWISE SHOWN.



STANDARD DETAIL

**POWER SUPPLY (42")
PEDESTAL AND BASE
ASSEMBLY**

APPROVED

MANAGER OF ENGINEERING DATE
DIRECTOR OF OPERATIONS DATE

REVISION No. DATE: DEC 2021
SCALE: N.T.S.

TSD-917

DIMENSION "c"
(NOTE 1)

OCTAGONAL POLE CAP

230mm

DIMENSION "a"
(NOTE 1)

230mm

460mm

460mm

POLE

11 GAUGE GALVANIZED
OCTAGONAL STEEL TRAFFIC
SIGNAL POLE SEE
FABRICATION DATA.

OCTAGONAL POLE

HANDHOLE DETAIL 'A'
COVER DETAIL 'B'

BASE PLATE

DIMENSION "b"
(NOTE 1)

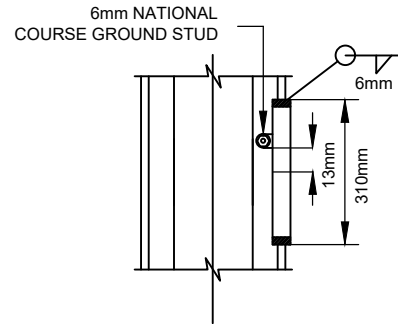
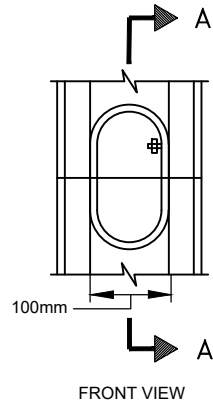

HAND HOLE DETAIL 'A'

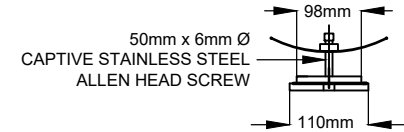

FABRICATION DATA			
POLE TYPE	POLE LENGTH "a" m	BOTTOM OUT. Ø "b" mm	TOP OUT. Ø "c" mm
PEDESTAL		206	206
8520	6.1	184	100
8524	7.3	184	100
8535	10.7	254	100
8545	13.7	254	100

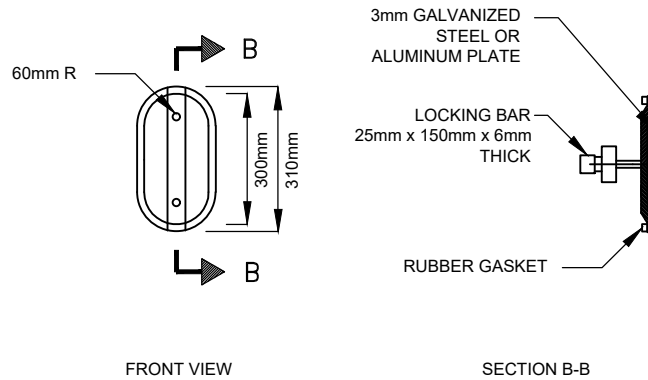

HAND HOLE COVER DETAIL 'B'

NOTES:

1. THE DIAMETER SHALL BE MEASURED ACROSS THE FLATS.
2. ALL DIMENSIONS ARE IN MILLIMETRES OR METRES UNLESS OTHERWISE SHOWN.



STANDARD DETAIL

GALVANIZED OCTAGONAL
STEEL POLE, BASE MOUNTED

APPROVED

MANAGER OF ENGINEERING DATE

DIRECTOR OF OPERATIONS DATE

REVISION No. DATE: MARCH 2020

SCALE: N.T.S.

TSD-918

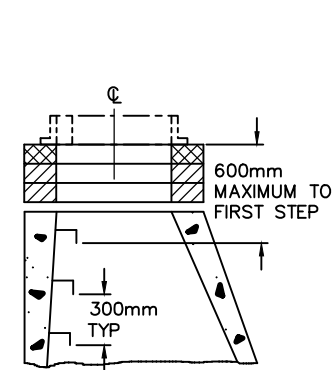

SECTION THROUGH
TAPER TOP

ALL JOINTS BETWEEN
UNITS ARE TO BE IN
ACCORDANCE WITH
MANUFACTURERS
SPECIFICATIONS AND
GUIDELINES WITH
APPROPRIATE
CAULKING.

THE FIRST
ADJUSTMENT UNIT
IS TO BE PLACED
IN MORTAR
(CONFORMING WITH
OPS 407.05.06) OR
CONCRETE
(CONFORMING WITH
OPS 407.05.01)
(TYPICAL)

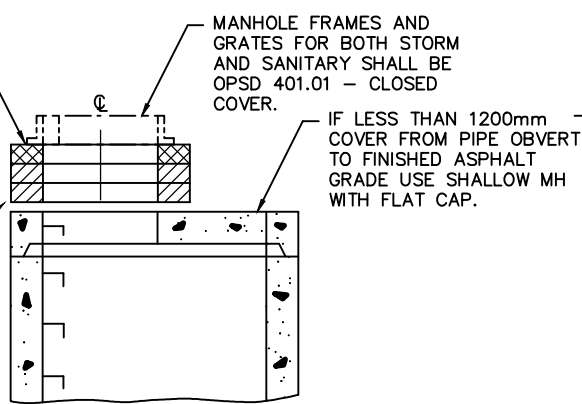

SECTION THROUGH
FLAT CAP

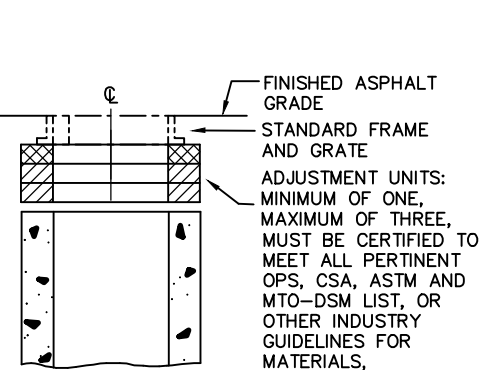

SECTION THROUGH
CATCH BASIN

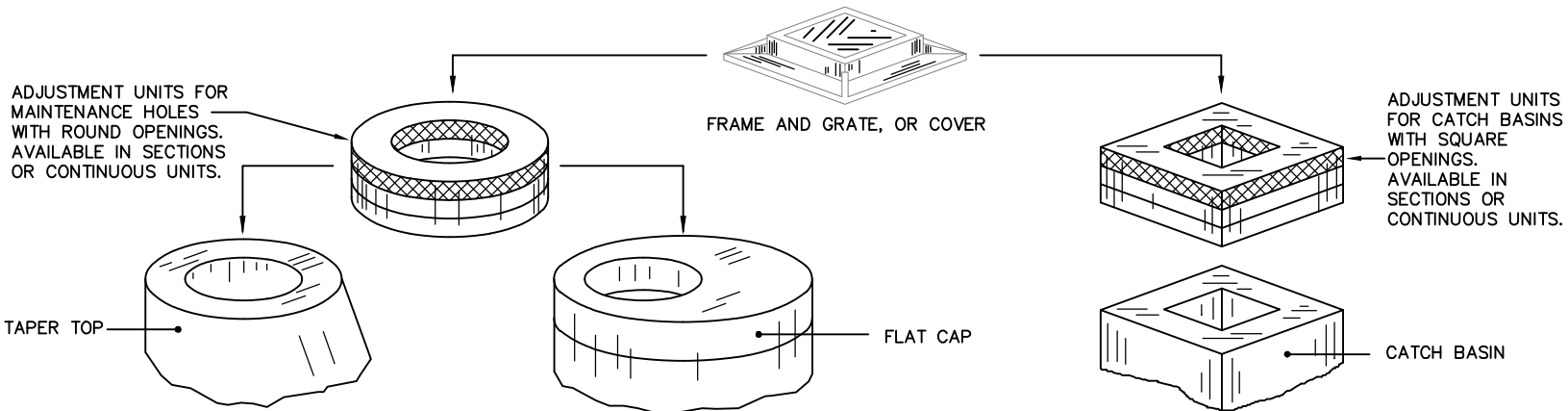

NOTES:

1. ADJUSTMENT UNITS SHALL NOT EXTEND BEYOND THE OUTSIDE EDGE OF THE STRUCTURE.
2. NON-COMPRESSIBLE BACK FILL WILL BE USED DURING REBUILDING, ADJUSTING, OR ANY OTHER APPLICABLE CATCH BASIN OR MAINTENANCE HOLE WORKS. GRANULAR MATERIAL SHALL BE PLACED TO A MIN. WIDTH OF 300MM ALL AROUND IN 300MM MAX, LIFTS COMPACTED TO 95% STANDARD PROCTOR.
3. MAINTENANCE HOLE TOPS (FRAMES) ARE TO BE SET TO BASE COURSE ASPHALT GRADE AND THEN ADJUSTED TO FINAL GRADE WHEN THE TOP LIFT OF ASPHALT IS PLACED. ALL ADJUSTMENT WILL BE ACCORDANCE WITH BSD-N2.
4. IF A STEP IS REQUIRED IN AN ADJUSTMENT UNIT, THEN THE ADJUSTMENT UNIT SHALL BE OF THE TYPE MANUFACTURED WITH A STEP IN PLACE.
5. ALL DIMENSIONS ARE IN MILLIMETRES UNLESS OTHERWISE SHOWN.
6. ADJUSTMENTS GREATER THAN 300mm REQUIRE INSTALLATION OF A CONTINUOUS UNIT.
7. PRECAST SECTIONS SHALL COMPLY WITH OPSPD 701.030, 701.031, & 701.032.
8. TOP LADDER RUNGS SHALL BE 600mm OR LESS BELOW DESIGN PROFILE GRADE. STEPS ARE NOT PERMITTED IN THE ADJUSTMENT UNITS.
9. BENCHING ON END MANHOLES TO EXTEND TO FAR INSIDE WALL. BENCHING ON LATERAL INLETS SHALL BE 500mm C/L RADIUS.
10. MANHOLES EXCEEDING 5.0m IN DEPTH SHALL INCLUDE A SAFETY GRATE LANDING AS PER OPSPD 404.020.
11. MANHOLES COVERRS SHALL BE SET ON GEOTEXTILE F.O.S 250 µm CL II OPSS 1860 UNTIL THE STREET IS PAVED.
12. MANHOLE BENCHING SHALL COMPLY WITH OPSPD 701.021.



STANDARD DETAIL

MAINTENANCE HOLE AND CATCH BASIN ADJUSTMENT UNITS

APPROVED

.....
MANAGER OF ENGINEERING DATE

.....
DIRECTOR OF OPERATIONS DATE

REVISION No. DATE: MARCH 2020

SCALE: N.T.S.

TSD-1010

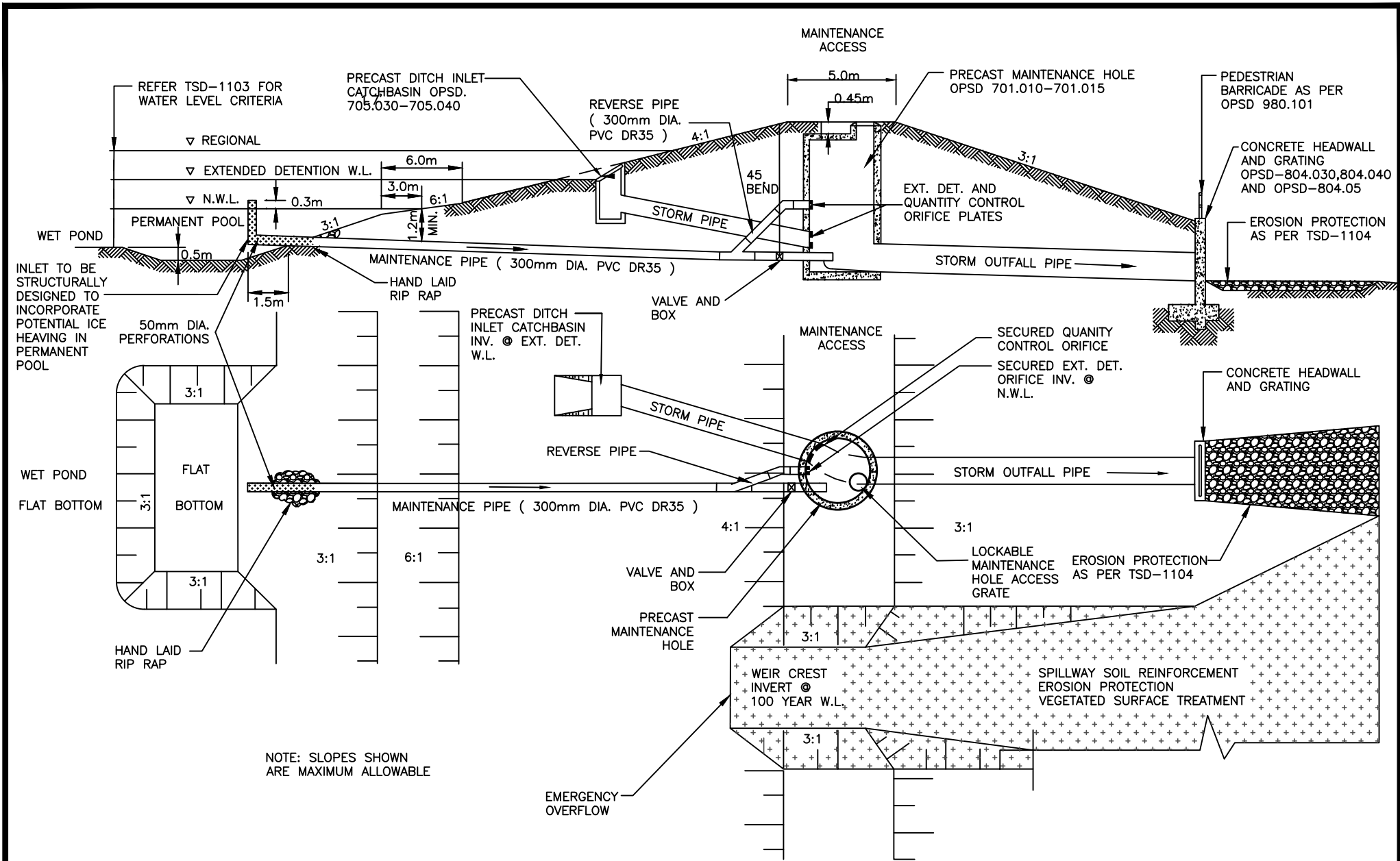

STANDARD DETAIL

OUTLET STRUCTURE TYPICAL DETAIL WET POND FACILITY WITH MAINTENANCE PIPE

APPROVED

MANAGER OF ENGINEERING DATE
DIRECTOR OF OPERATIONS DATE

REVISION No. DATE: FEB 2022
SCALE: N.T.S.

TSD-1100

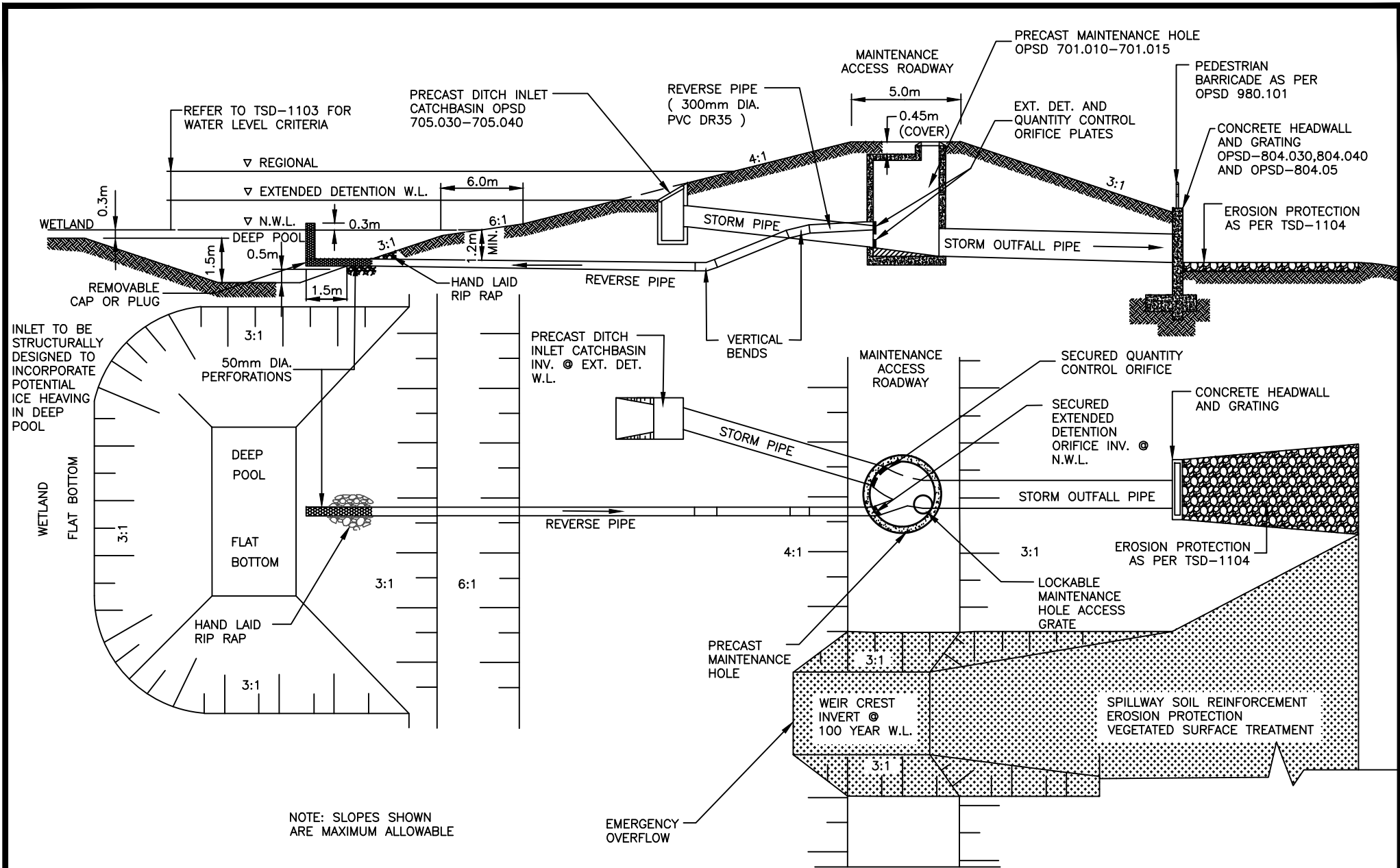

STANDARD DETAIL

OUTLET STRUCTURE TYPICAL DETAIL WETLAND FACILITY WITHOUT MAINTENANCE PIPE

APPROVED

MANAGER OF ENGINEERING DATE
DIRECTOR OF OPERATIONS DATE

REVISION No. DATE: FEB 2022
SCALE: N.T.S.

TSD-1101

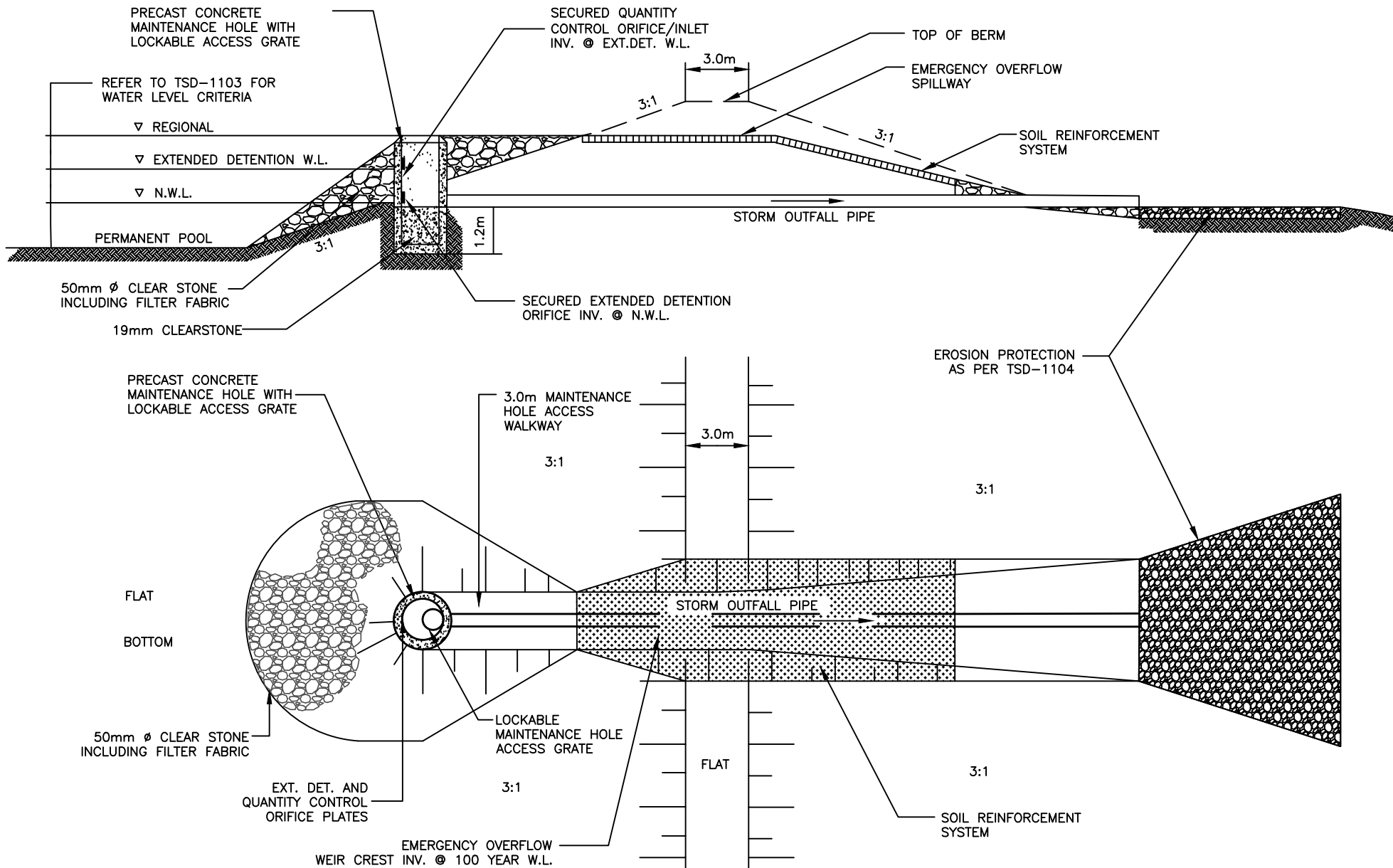

STANDARD DETAIL

TEMPORARY OUTLET STRUCTURE TYPICAL DETAIL

APPROVED

MANAGER OF ENGINEERING DATE

DIRECTOR OF OPERATIONS DATE

REVISION No. DATE: FEB 2022

SCALE: N.T.S.

TSD-1102

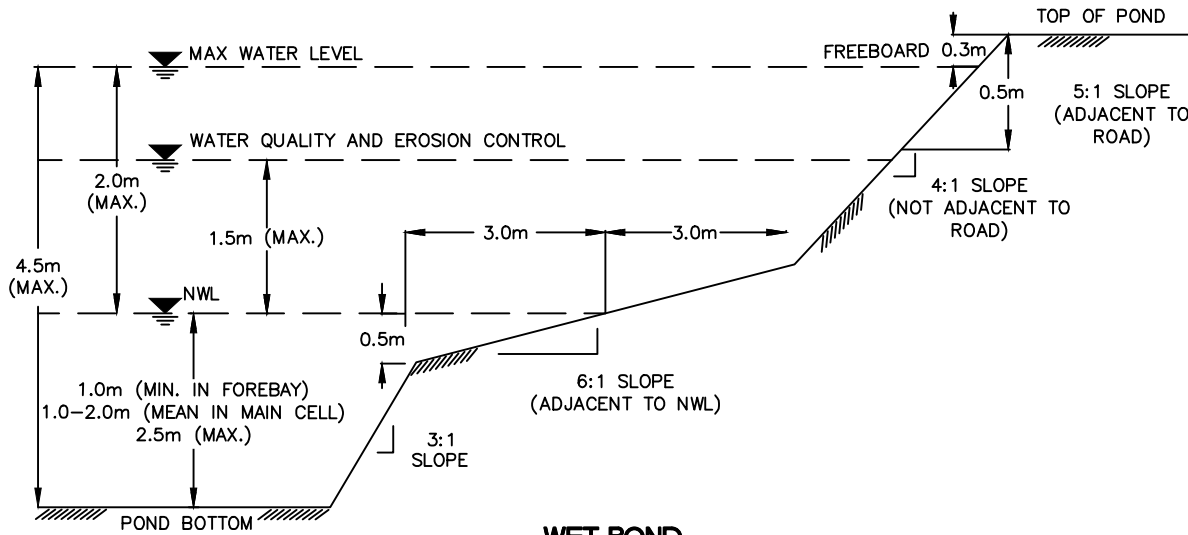

WET POND
N.T.S.

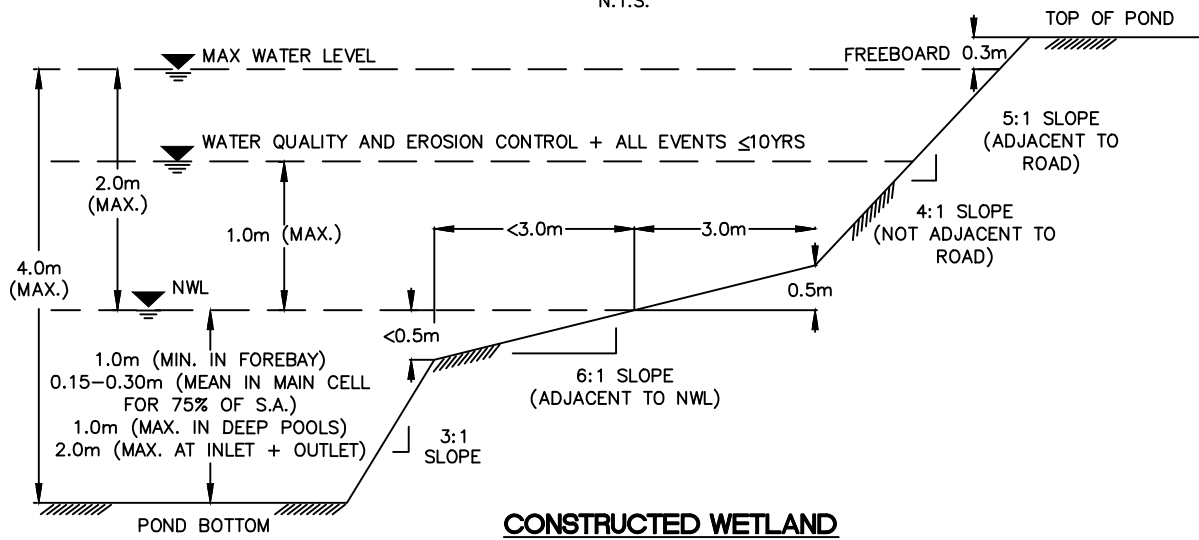

CONSTRUCTED WETLAND

NOTES:

FOR HYBRID WET POND / WETLAND FACILITIES, THE ABOVE NOTED CRITERIA FOR DEPTH AND SLOPE SHALL APPLY TO THE RESPECTIVE WET POND AND WETLAND COMPONENTS OF THE HYBRID FACILITY WITH THE FOLLOWING CLARIFICATION:

1. DEPTH FOR ACTIVE STORAGE SHALL NOT EXCEED THE CRITERIA FOR A WETLAND UNLESS A TERRACED OVERFLOW CONFIGURATION IS EMPLOYED.
2. THE MINIMUM LENGTH TO WIDTH RATIO FOR THE WET POND COMPONENT SHALL BE 2:1.



STANDARD DETAIL

SWM FACILITY GRADING AND WATER LEVEL CRITERIA

APPROVED

MANAGER OF ENGINEERING DATE
DIRECTOR OF OPERATIONS DATE

REVISION No. DATE: MARCH 2020
SCALE: N.T.S.

TSD-1103

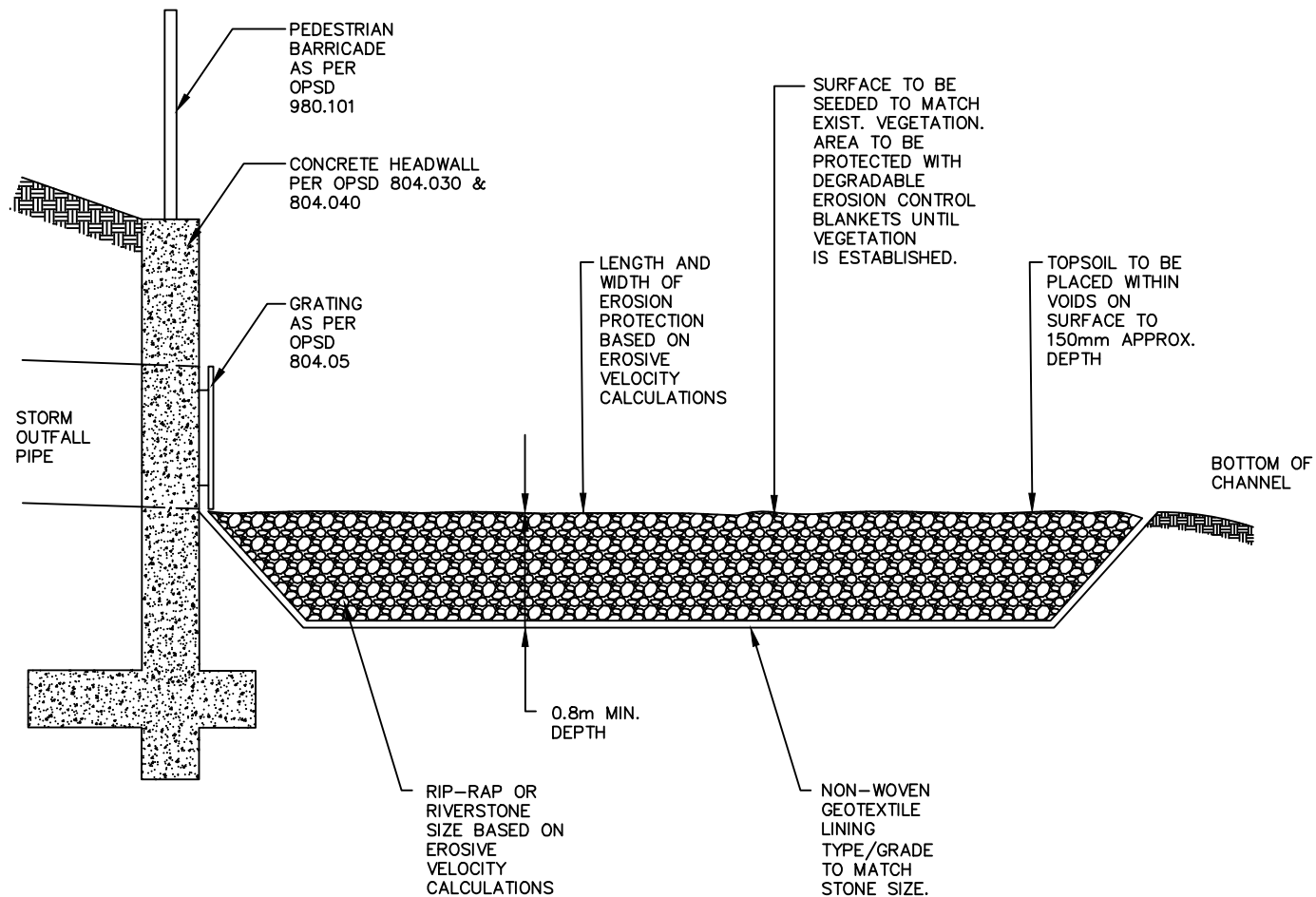

STANDARD DETAIL

OUTLET EROSION PROTECTION TYPICAL DETAIL

APPROVED

MANAGER OF ENGINEERING DATE

DIRECTOR OF OPERATIONS DATE

REVISION No. DATE: MARCH 2020

SCALE: N.T.S.

TSD-1104

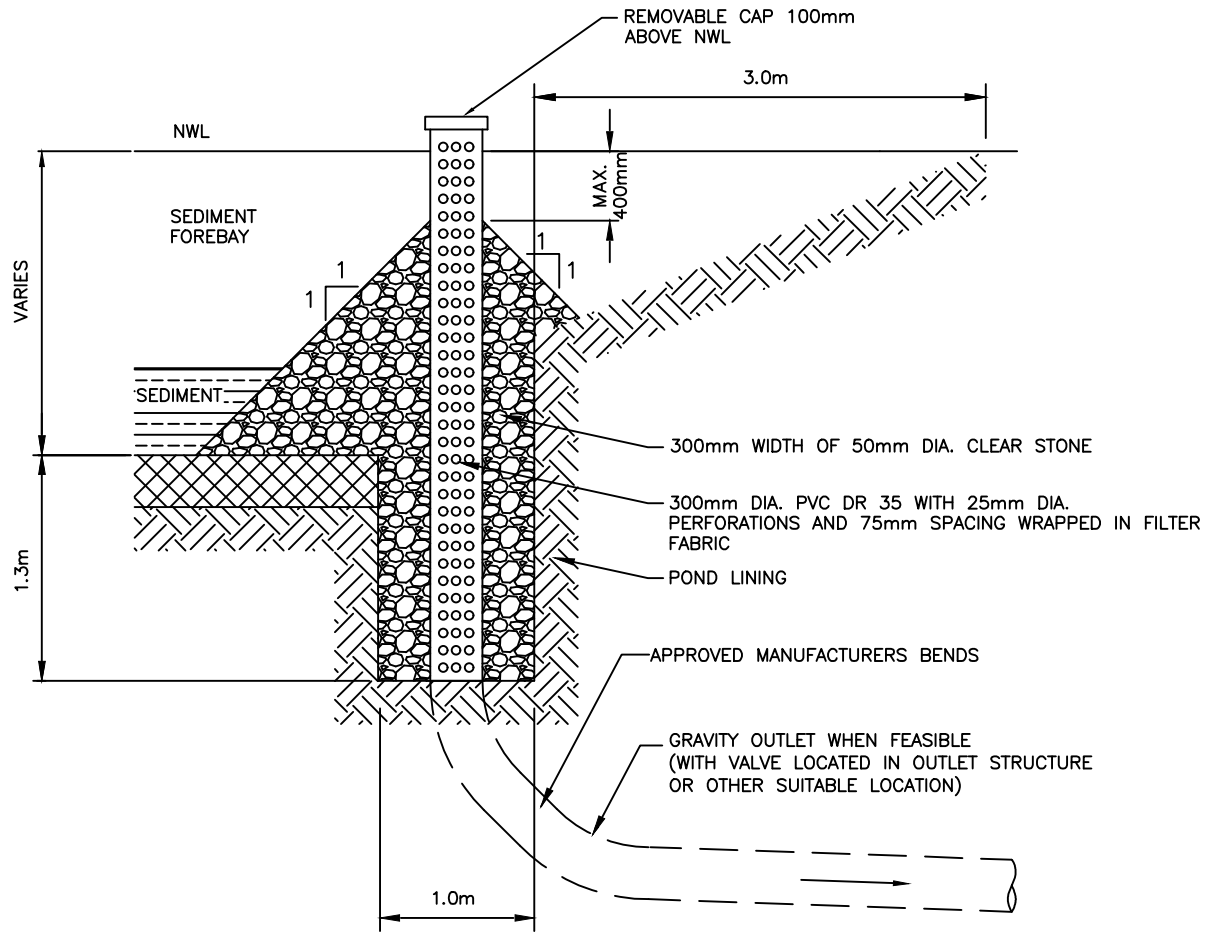

STANDARD DETAIL

FOREBAY HICKENBOTTOM DETAIL

APPROVED

MANAGER OF ENGINEERING DATE
 DIRECTOR OF OPERATIONS DATE

REVISION No. DATE: MARCH 2020
 SCALE: N.T.S.

TSD-1105

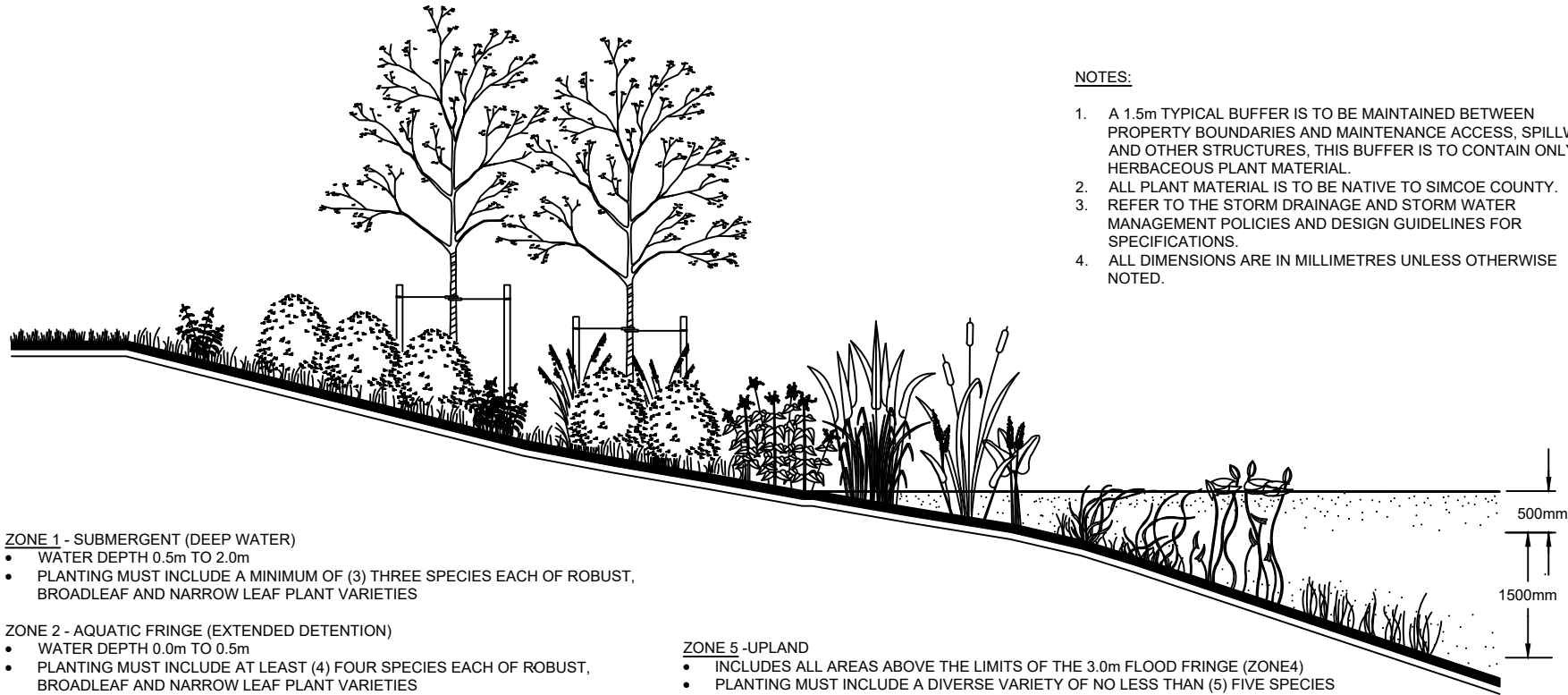

NOTES:

1. A 1.5m TYPICAL BUFFER IS TO BE MAINTAINED BETWEEN PROPERTY BOUNDARIES AND MAINTENANCE ACCESS, SPILLWAYS AND OTHER STRUCTURES, THIS BUFFER IS TO CONTAIN ONLY HERBACEOUS PLANT MATERIAL.
2. ALL PLANT MATERIAL IS TO BE NATIVE TO SIMCOE COUNTY.
3. REFER TO THE STORM DRAINAGE AND STORM WATER MANAGEMENT POLICIES AND DESIGN GUIDELINES FOR SPECIFICATIONS.
4. ALL DIMENSIONS ARE IN MILLIMETRES UNLESS OTHERWISE NOTED.

ZONE 1 - SUBMERGENT (DEEP WATER)

- WATER DEPTH 0.5m TO 2.0m
- PLANTING MUST INCLUDE A MINIMUM OF (3) THREE SPECIES EACH OF ROBUST, BROADLEAF AND NARROW LEAF PLANT VARIETIES

ZONE 2 - AQUATIC FRINGE (EXTENDED DETENTION)

- WATER DEPTH 0.0m TO 0.5m
- PLANTING MUST INCLUDE AT LEAST (4) FOUR SPECIES EACH OF ROBUST, BROADLEAF AND NARROW LEAF PLANT VARIETIES

ZONE 3 - SHORELINE FRINGE (EXTENDED DETENTION)

- 1.0m (HORIZONTAL) FROM THE PERMANENT POOL ELEVATION
- PLANTING ZONE TO CONTAIN WETLAND SPECIES AND MUST INCLUDE PERENNIAL SEDGES, RUSHES AND WILD FLOWERS IN COMBINATION WITH SHRUBS AND WETLAND SEED MIX

ZONE 4 - FLOOD FRINGE

- 2.0m (HORIZONTAL) FROM LIMIT OF SHORELINE FRINGE LIMIT OR TO THE 100 YEAR FLOOD LEVEL (WHICHEVER IS GREATER)
- PLANTING MUST INCLUDE A DIVERSE VARIETY OF NO LESS THAN (4) FOUR TOLERANT SPECIES EACH OF SHRUBS, DECIDUOUS TREES, CONIFEROUS TREES AND AN UPLAND SEED MIX

ZONE 5 - UPLAND

- INCLUDES ALL AREAS ABOVE THE LIMITS OF THE 3.0m FLOOD FRINGE (ZONE4)
- PLANTING MUST INCLUDE A DIVERSE VARIETY OF NO LESS THAN (5) FIVE SPECIES EACH OF DROUGHT TOLERANT SHRUBS, DECIDUOUS TREES, CONIFEROUS TREES AND AN UPLAND SEED MIX



STANDARD DETAIL

STORMWATER PLANTING ZONE COMPOSITION

APPROVED

.....
MANAGER OF ENGINEERING DATE

.....
DIRECTOR OF OPERATIONS DATE

REVISION No.

DATE: MARCH 2020

SCALE: N.T.S.

TSD-1106

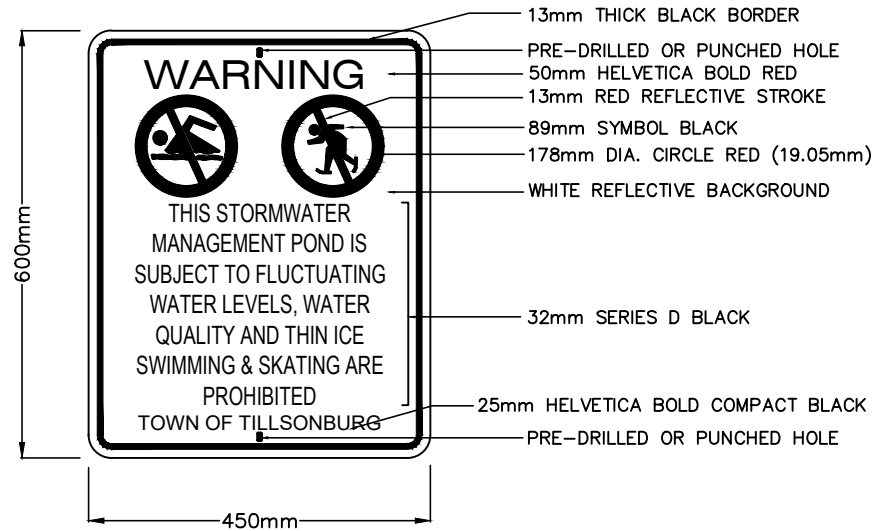
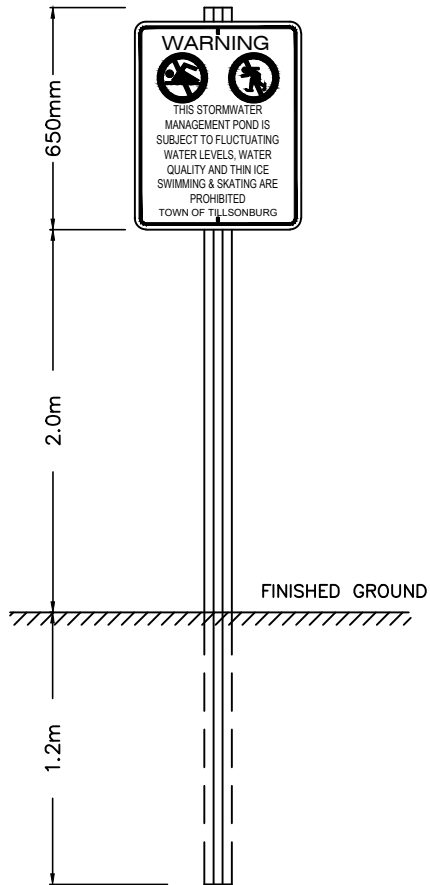

SIGN REQUIREMENTS

SIGN(S) MUST BE PLACED AT ALL POND ENTRANCES.

SIGNAGE FACE

SIGN(S) TO BE MANUFACTURED USING REFLECTIVE FINISH (ENGINEER GRADE) 3.2mm THICK ALUMINUM PANEL (50mm RADIUS CORNERS), WITH TOP AND BOTTOM MOUNT HOLES.

MOUNTING

SIGN(S) TO BE MOUNTED TO 3.85m U-CHANNEL GALVANIZED STEEL POST.



STANDARD DETAIL

STORMWATER MANAGEMENT POND WARNING SIGN

APPROVED

.....
MANAGER OF ENGINEERING DATE

.....
DIRECTOR OF OPERATIONS DATE

REVISION No. DATE: DEC 2021

SCALE: N.T.S.

TSD-1110

AS SPECIFIED FOR CONVENTIONAL SEWER CONNECTIONS, OWNERS ARE RESPONSIBLE FOR MAINTENANCE OF THE CONNECTION FROM THE SEWER TO THE BUILDING. THIS INCLUDES ALL FITTINGS AND PIPE FROM THE MAINTENANCE HOLE BENCHING TO THE BUILDING.

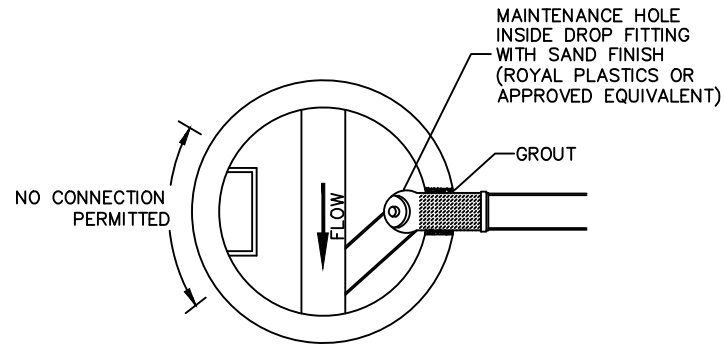
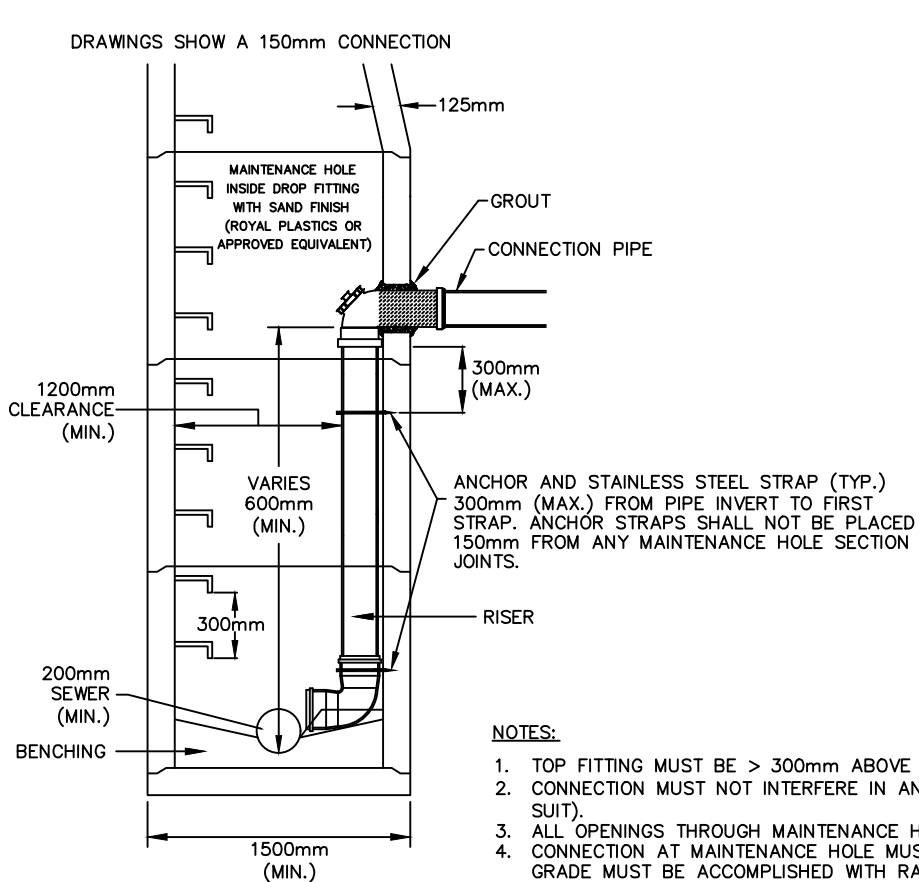

- INTERNAL DROP STRUCTURE SYSTEMS SHALL CONFORM TO APPLICABLE OXFORD COUNTY SPECIFICATIONS AND OPSD 1003.031.
- INTERNAL DROP STRUCTURES SHALL BE USED IN MAINTENANCE HOLES 1500mm AND LARGER WHERE A MINIMUM HEIGHT OF 600mm FROM INLET PIPE INVERT TO THE BOTTOM OF THE CHANNEL EXISTS.
- SERVICE CONNECTIONS ARE TO BE MADE TO SEWERS AS PER TOWN AND COUNTY POLICIES, UNLESS OTHERWISE APPROVED BY THE MANAGER OF ENGINEERING.
- ALL APPLICATIONS FOR INSIDE DROP SERVICE CONNECTIONS TO MAINTENANCE HOLES MUST BE ACCOMPANIED BY A PLAN AND PROFILE DRAWING (TO SCALE) SHOWING THE PROPOSED CONNECTION ALIGNMENT, SEWER MAIN, LADDER, SAFETY GRATES AND ANY OTHER CONNECTIONS TO THE MAINTENANCE HOLE. (PROFILE MUST SHOW ENTIRE MAINTENANCE HOLE INCLUDING FRAME).

NOTES:

- TOP FITTING MUST BE > 300mm ABOVE OR BELOW SAFETY GRATES.
- CONNECTION MUST NOT INTERFERE IN ANY WAY WITH ACCESS, LADDERS NOR SAFETY GRATE USE OR OPERATION (SAFETY GRATE ADJUSTED TO SUIT).
- ALL OPENINGS THROUGH MAINTENANCE HOLE WALLS MUST BE CORE DRILLED.
- CONNECTION AT MAINTENANCE HOLE MUST BE < 4% GRADE, AND WITHIN 30° TO PERPENDICULAR. ANY ADJUSTMENTS TO CONNECTION DIRECTION OR GRADE MUST BE ACCOMPLISHED WITH RADIUS BEND FITTINGS PER OPS.
- ALL VOIDS IN OPENINGS THROUGH MAINTENANCE HOLE WALLS MUST BE GROUTED WITH OPS APPROVED NON-SHRINK MORTAR.
- ALL FITTINGS AND RISER PIPES WILL BE SECURED TO THE MAINTENANCE HOLE WALL WITH STAINLESS STRAPPING AND 1" SCREWS; MINIMUM 1 (ONE) STRAP PER SECTION OF RISER PIPE OR FITTING.
- BENCHING MUST DIRECT FLOW WITH SEWER MAIN FLOW AND BE TO SPRING-LINE OF BOTTOM FITTING.
- DROP PIPES SHALL BE ONE SIZE SMALLER THAN THE INCOMING SEWER WITH A MINIMUM OF 150mm DIAMETER AND A MAXIMUM OF 375mm DIAMETER.



STANDARD DETAIL

PVC INSIDE DROP SEWER SERVICE CONNECTION

APPROVED

..... MANAGER OF ENGINEERING DATE

..... DIRECTOR OF OPERATIONS DATE

REVISION No. DATE: DEC 2021

SCALE: N.T.S.

TSD-1200

DRAWINGS SHOW A 250mm SEWER

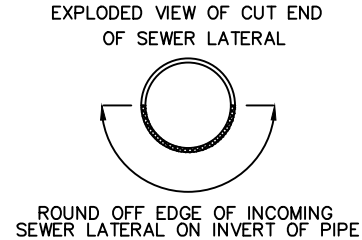
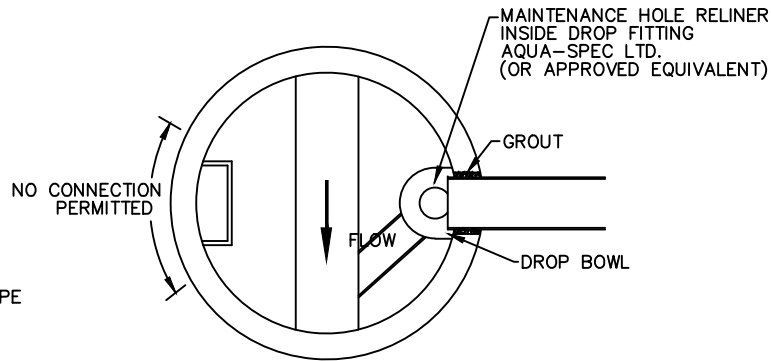
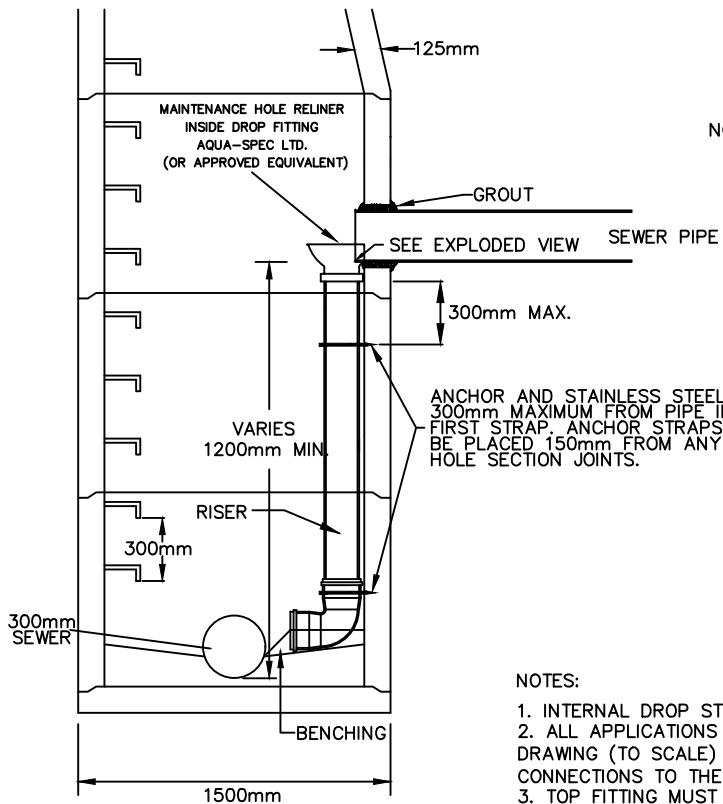

NOTES:

1. INTERNAL DROP STRUCTURE SYSTEMS SHALL CONFORM TO APPLICABLE OXFORD COUNTY SPECIFICATIONS AND OPSD 1003.031.
2. ALL APPLICATIONS FOR INSIDE DROP SEWER CONNECTIONS TO MAINTENANCE HOLES MUST BE ACCOMPANIED BY A PLAN AND PROFILE DRAWING (TO SCALE) SHOWING THE PROPOSED CONNECTION ALIGNMENT, SEWER MAIN, LADDER, SAFETY GRATES AND ANY OTHER CONNECTIONS TO THE MAINTENANCE HOLE. (PROFILE MUST SHOW ENTIRE MAINTENANCE HOLE INCLUDING FRAME).
3. TOP FITTING MUST BE > 300mm ABOVE OR BELOW SAFETY GRATES.
4. CONNECTION MUST NOT INTERFERE IN ANY WAY WITH ACCESS, LADDERS NOR SAFETY GRATE USE OR OPERATION. (SAFETY GRATE ADJUSTED TO SUIT)
5. ALL OPENINGS THROUGH MAINTENANCE HOLE WALLS MUST BE CORE DRILLED.
6. CONNECTION AT MAINTENANCE HOLE MUST BE < 4% GRADE, AND TO BE PERPENDICULAR TO THE WALL OF THE MAINTENANCE HOLE.
7. ALL VOIDS IN OPENINGS THROUGH MAINTENANCE HOLE WALLS MUST BE GROUTED WITH APPROVED NON-SHRINK MORTAR, PER OPS.
8. ALL FITTINGS AND RISER PIPES WILL BE SECURED TO THE MAINTENANCE HOLE WALL WITH STAINLESS STRAPPING AND 1" SCREWS; MINIMUM 1 (ONE) STRAP PER SECTION OF RISER PIPE OR FITTING.
9. BENCHING MUST DIRECT FLOW WITH SEWER MAIN FLOW AND BE TO SPRING-LINE OF BOTTOM FITTING.
10. DROP PIPE TO BE ONE SIZE SMALLER THAN INCOMING SEWER WITH A MINIMUM OF 150mm DIA. AND MAX. OF 375mm DIA.
11. INTERNAL DROP STRUCTURE TO BE USED ON MAINTENANCE HOLES 1500mm DIA. AND LARGER ONLY.



STANDARD DETAIL

PVC INSIDE DROP SEWER MAINTENANCE HOLE

APPROVED

MANAGER OF ENGINEERING DATE
DIRECTOR OF OPERATIONS DATE

REVISION No. DATE: DEC 2021
SCALE: N.T.S.

TSD-1201

GENERAL NOTES - WATERMAIN

1. CONTRACTORS SHALL INFORM THE TOWN OF TILLSONBURG WATER/ WATSEWATER DEPARTMENT A MINIMUM OF 72 HOURS IN ADVANCE OF THEIR INTENTIONS TO PERFORM WORK ON WATER INFRASTRUCTURE.
2. OPERATION OF HYDRANTS AND VALVES ON THE POTABLE WATER SYSTEM BY OTHER THAN QUALIFIED WATER OPERATIONS STAFF IS PROHIBITED BY CURRENT BY-LAW. TOWN SERVICE FEES ARE PER THE CURRENT FEES BY-LAW. THE TOWN'S WATER OPERATIONS STAFF IS TO BE PRESENT DURING THE SWABBING, PRESSURE TESTING, CHLORINATION AND FLUSHING OF ALL NEW WATERMAINS.
3. MINIMUM COVER OVER WATERMAIN SHALL BE 1.8m. THE MINIMUM HORIZONTAL SEPARATION BETWEEN WATERMAIN AND SEWERS SHALL BE 3.0m. WHERE WATERMAIN CONFLICTS WITH SEWER PIPES, DEFLECT WATERMAIN HORIZONTALLY OR VERTICALLY WHILE PROVIDING A MINIMUM OF 0.5m CLEARANCE BETWEEN WATERMAIN AND SEWERS. MAINTAIN MINIMUM DEPTH OF COVER AT ALL TIMES.
4. WATERMAIN SHALL BE INSTALLED IN BEDDING AS PER OPSD 802.010 (GRANULAR 'A' EMBEDMENT MATERIAL) FOR FLEXIBLE PIPES AND OPSD 802.030 OR 802.031 CLASS 'B' (GRANULAR 'A' BEDDING MATERIAL, GRANULAR 'A' OR SELECT NATIVE COVER MATERIAL) FOR RIGID PIPE UNLESS OTHERWISE APPROVED BY TOWN ENGINEERING. ALTERNATIVE EMBEDMENT MATERIAL - SAND MEETING GRADATION REQUIREMENTS OF OPSS.MUNI 1004.05.07 COMPACTED TO 95% STANDARD PROCTOR MAXIMUM DRY DENSITY IS PERMISSIBLE WHERE NOTED IN STANDARD DETAILS. GEOTECHNICAL CERTIFICATION OF MATERIAL AND COMPACTION TESTING MUST BE PROVIDED EVERY 150 METRES. THE COMPACTION TESTING MUST INCLUDE THE ENTIRE EMBEDMENT ENVELOPE (HAUNCHES, BEDDING, TOP OF PIPE AND COVER).
5. COPPER WATERMAINS AND SERVICES 25mm TO 50mm IN DIAMETER SHALL BE EMBEDDED IN SAND 100mm ABOVE AND BELOW TO CONFORM TO OPSS.MUNI 1004.05.07. COPPER WATERMAINS ARE NOT PERMITTED IN NEW CONSTRUCTION AS PER OXFORD COUNTY DESIGN GUIDELINES AND SPECIFICATIONS.
6. MECHANICAL RESTRAINTS WILL BE REQUIRED ON ALL HYDRANTS. THRUST BLOCKS, AS PER OPSD 1103.010 AND 1103.020 MAY BE REQUIRED IN ADDITION TO STANDARD MECHANICAL RESTRAINTS WHERE SOIL CONDITIONS WARRANT AT THE TOWN'S DISCRETION.
7. NEW WATERMAINS TO BE PVC DR18 CL235 MINIMUM; DUCTILE IRON CEMENT MORTAR LINED CL52 AS PER THE OXFORD COUNTY DESIGN GUIDELINES AND SPECIFICATIONS.
8. TRACING WIRE SHALL BE #12 AWG HIGH STRENGTH COPPER CLAD (HS-CSS) AND SHALL BE INSTALLED ON THE TOTAL LENGTH OF ALL WATERMAIN AND BROUGHT UP AT EACH HYDRANT AND CONNECTED TO FLANGE BOLT. ALL SPLICES TO UTILIZE CONNECTORS AS PER OXFORD COUNTY DESIGN GUIDELINES AND SPECIFICATIONS.
9. ALL WATER SERVICES SHALL BE 25mm CROSS-LINKED POLYETHYLENE OR 25mm HIGH DENSITY POLYETHYLENE (HDPE) UNLESS OTHERWISE APPROVED BY THE TOWN ENGINEERING DEPARTMENT. WATER SERVICE SADDLES SHALL BE USED WHEN TAPPING INTO PVC WATERMAIN.
10. SERVICE TAPPINGS SHALL BE PLACED AT A MINIMUM SEPARATION OF 1.0m AND A MINIMUM OF 0.6m FROM JOINTS. (ENDS OF PIPE)
11. RISER PIPES ARE TO BE INSTALLED AS PER TSD-1340, AND REMOVED AS DIRECTED. SWABBING SCHEDULE TO BE SUPPLIED BY A WATER OPERATIONS FIELD REPRESENTATIVE. ALL RISERS ARE TO BE RESTRAINED OR THRUST BLOCKED.
12. ALL NEW CURB STOPS AND BOXES TO BE LOCATED AT PROPERTY LINE.



STANDARD DETAIL

**GENERAL NOTES
WATERMAIN**

APPROVED

.....
MANAGER OF ENGINEERING DATE
.....
DIRECTOR OF OPERATIONS DATE

REVISION No. DATE: MARCH 2020

SCALE: N.T.S.

TSD-1300

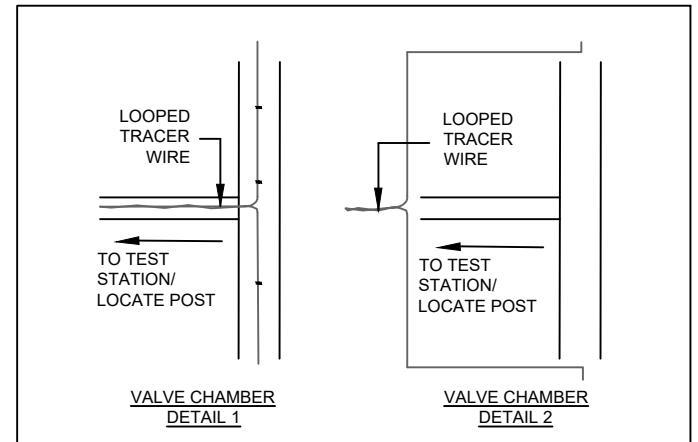
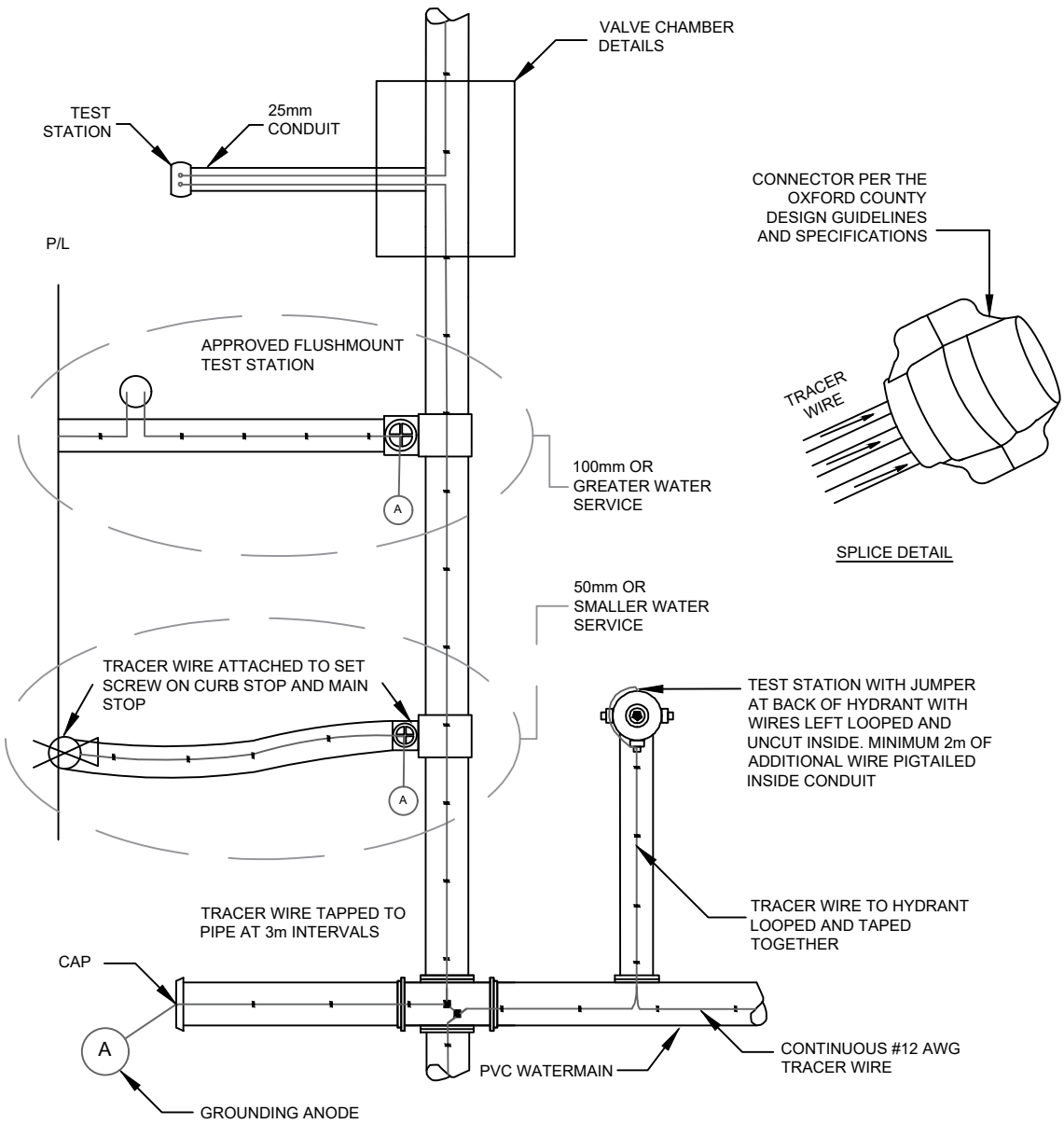

DETAIL NOTES:

1. TRACER WIRE IS NOT PERMITTED TO TERMINATE INSIDE OF A CHAMBER.
2. TRACER WIRE IS NOT PERMITTED TO RUN ON TOP OF A CHAMBER.
3. TRACER WIRE MAY RUN THROUGH A CHAMBER AT DEPTH OF THE WATERMAIN UNTIL DIRECTLY UNDER A LOCATE POST THEN BE BROUGHT UP INTO THE LOCATE POST (DETAIL 1). ALTERNATIVELY, TRACER WIRE MAY RUN AROUND THE OUTSIDE OF THE CHAMBER AT THE DEPTH OF THE WATERMAIN UNTIL DIRECTLY UNDER A LOCATE POST THEN BE BROUGHT UP INTO THE LOCATE POST (DETAIL 2).

NOTES:

1. TRACER WIRE TO BE INSTALLED AS PER TOWN OF TILLSONBURG AND OXFORD COUNTY DESIGN STANDARDS.
2. HYDRANT TEST STATION CONDUIT SHALL BE A MINIMUM OF 25mm INSTALLED TO A DEPTH OF 600mm BELOW GRADE.
3. ALL CONNECTIONS MUST BE WATERPROOFED.
4. SPLICING OF TRACER WIRE IS NOT ALLOWED UNLESS SPECIFIED OR APPROVED.



STANDARD DETAIL

TRACER WIRE DETAIL

APPROVED

.....
MANAGER OF ENGINEERING DATE

.....
DIRECTOR OF OPERATIONS DATE

REVISION No. DATE: MARCH 2020

SCALE: N.T.S.

TSD-1301

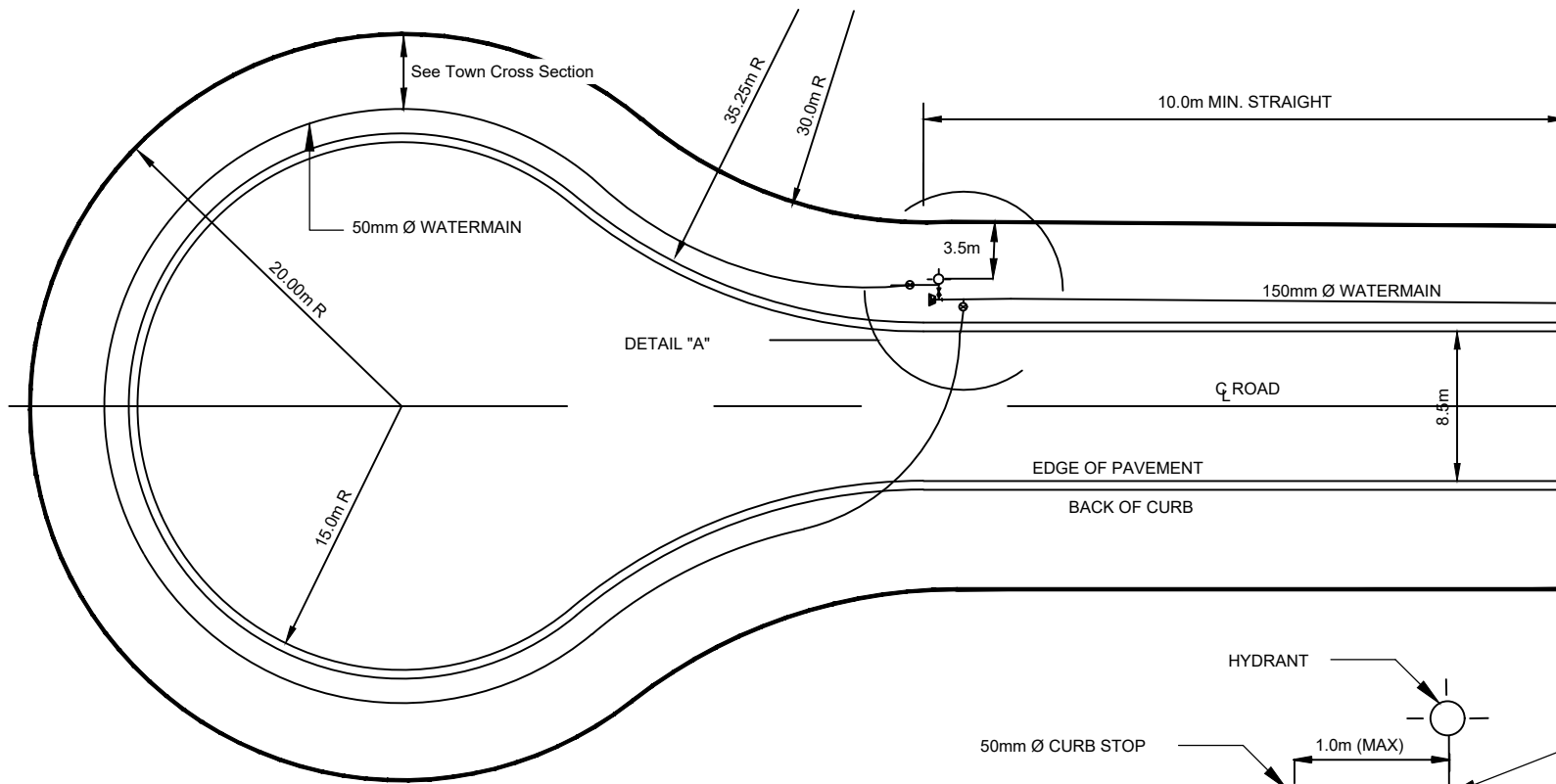

NOTES:

1. MAXIMUM SERVICE SIZE IS 25mm.
2. MAXIMUM OF 7 SERVICES OFF OF 50mm Ø.
3. RESTRAIN JOINTS WHERE REQUIRED.
4. MATERIAL SHALL BE PEX OR P.E SERIES 200.
5. ALL NON-METALLIC PIPE SHALL REQUIRE STAINLESS STEEL INSERT
6. TRACER WIRE TO BE INSTALLED AS PER OXFORD COUNTY DESIGN GUIDELINES AND SPECIFICATIONS

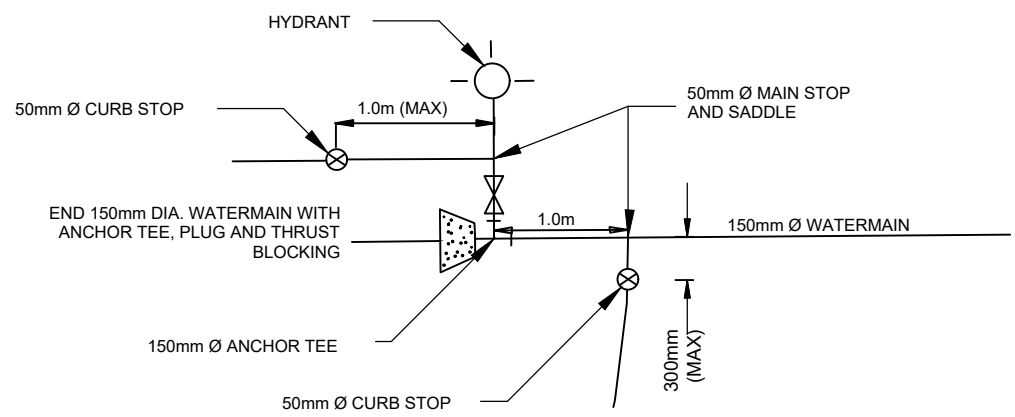

DETAIL "A"



STANDARD DETAIL

**TYPICAL CUL-DE-SAC
WATERMAIN DESIGN
(50mm DIA. LOOP)**

APPROVED

MANAGER OF ENGINEERING DATE
DIRECTOR OF OPERATIONS DATE

REVISION No. DATE: DEC 2021
SCALE: N.T.S.

TSD-1306

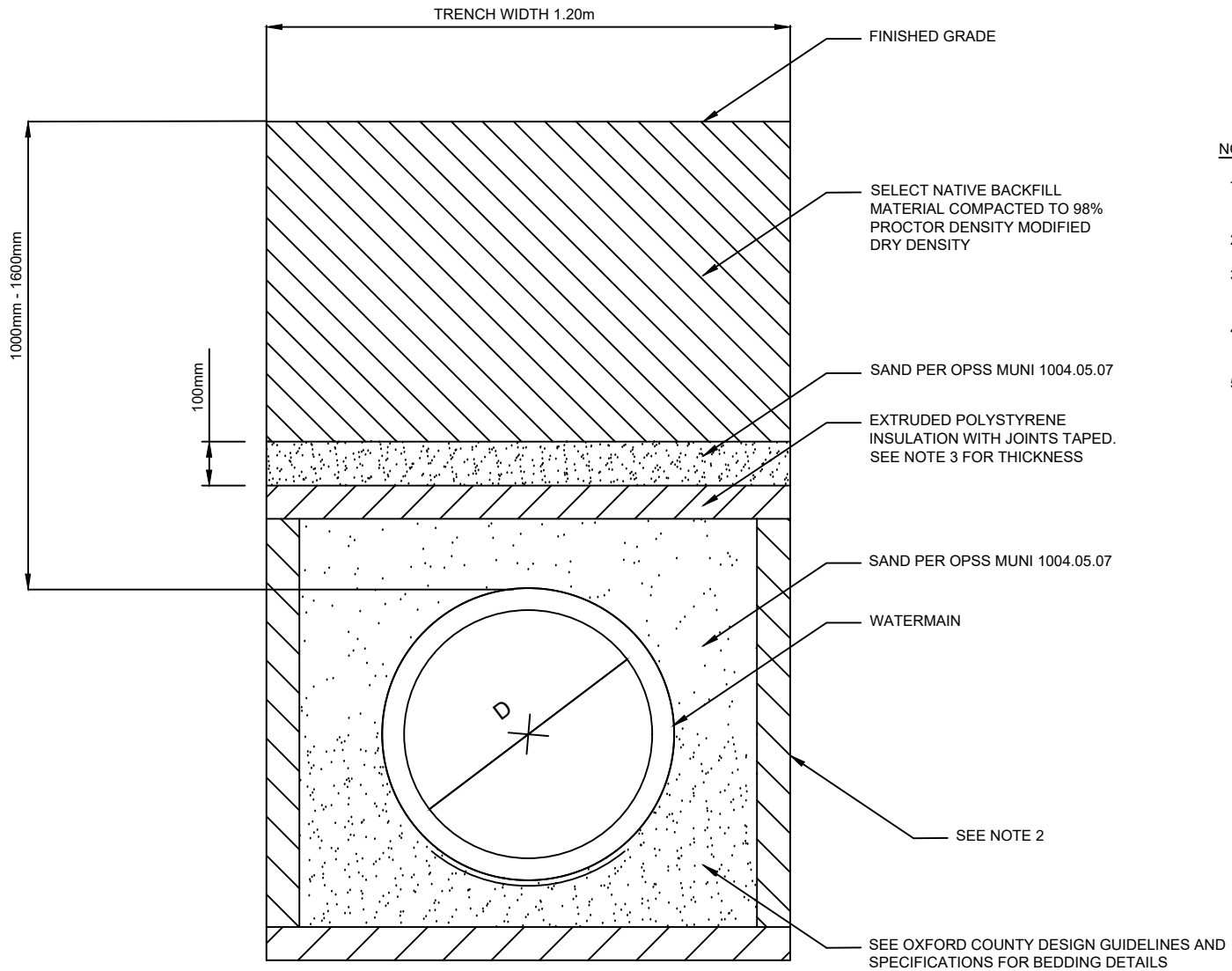

NOTES:

1. TYPICAL DETAIL ONLY, THERMAL PROTECTION SHALL BE DESIGNED "SITE SPECIFIC" PER MINISTRY OF ENVIRONMENT DESIGN GUIDELINES.
2. FOR CROSSING OR UNDERGROUND STRUCTURES OR CONDUIT A "FROST BOX" IS REQUIRED.
3. IF GROUND COVER IS 1.3m -1.6m USE 50mm THICK INSULATION. IF GROUND COVER IS BETWEEN 1.0m - 1.3m USE 75mm THICK INSULATION.
4. FOR WATERMAIN AND SERVICES LOCATED 500mm OR LESS HORIZONTALLY ADJACENT TO MANHOLES OR CATCHBASIN, A MINIMUM 50mm INSULATION IS REQUIRED.
5. ALL UNITS IN MILLIMETERS UNLESS OTHERWISE NOTED.



STANDARD DETAIL

TYPICAL INSULATION DETAIL

APPROVED

.....
 MANAGER OF ENGINEERING DATE

 DIRECTOR OF OPERATIONS DATE

REVISION No.	DATE: DEC 2021
	SCALE: N.T.S.

TSD-1307

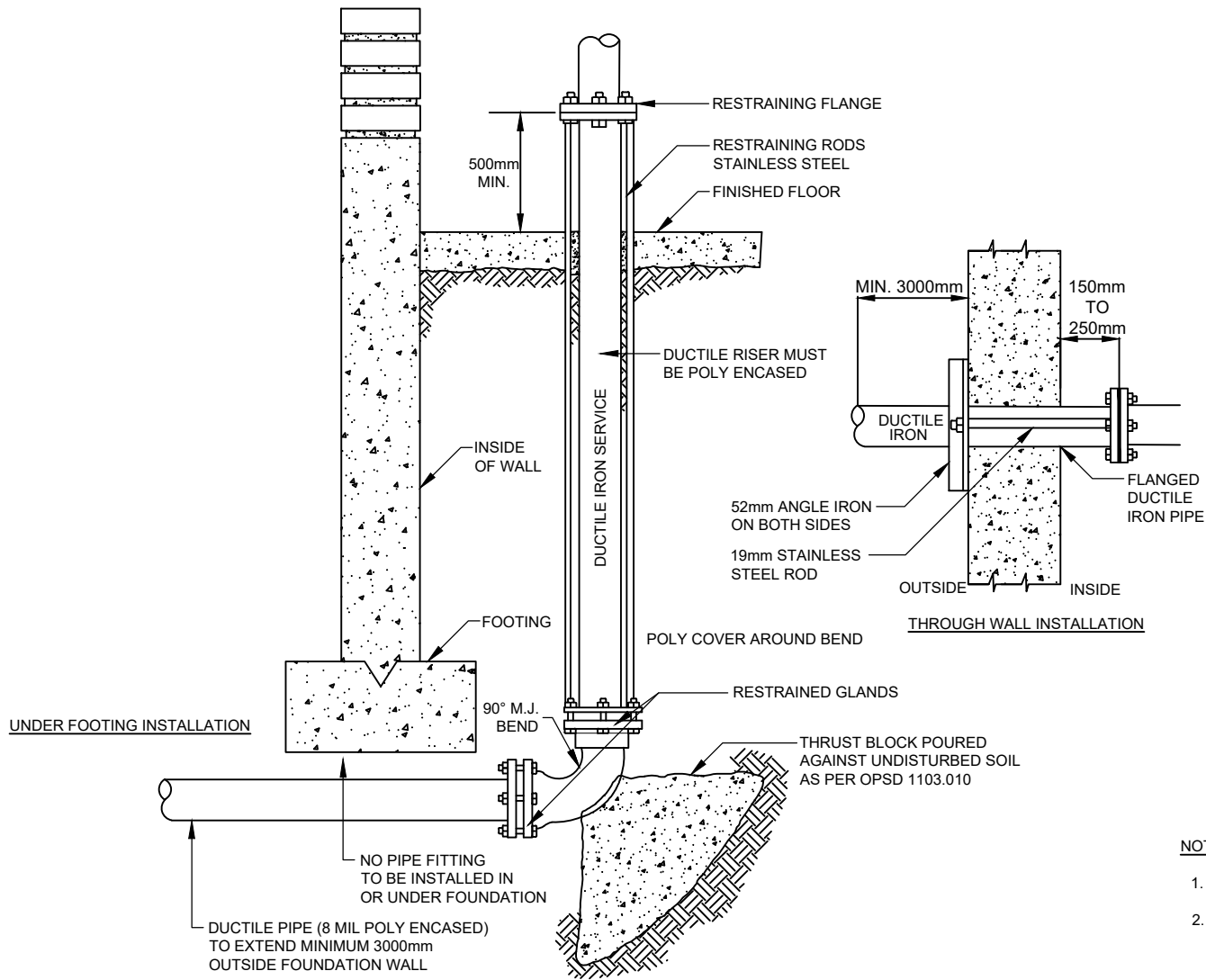

NOTES:

1. INSTALLATION MUST MEET THE CURRENT NATIONAL FIRE PROTECTION ACT.
2. ALL DIMENSIONS ARE IN MILLIMETERS UNLESS OTHERWISE SHOWN.



STANDARD DETAIL

**TYPICAL SERVICE ENTRY
100mm TO 300mm
DIAMETER PIPE**

APPROVED

MANAGER OF ENGINEERING DATE
DIRECTOR OF OPERATIONS DATE

REVISION No. DATE: MARCH 2020
SCALE: N.T.S.

TSD-1320

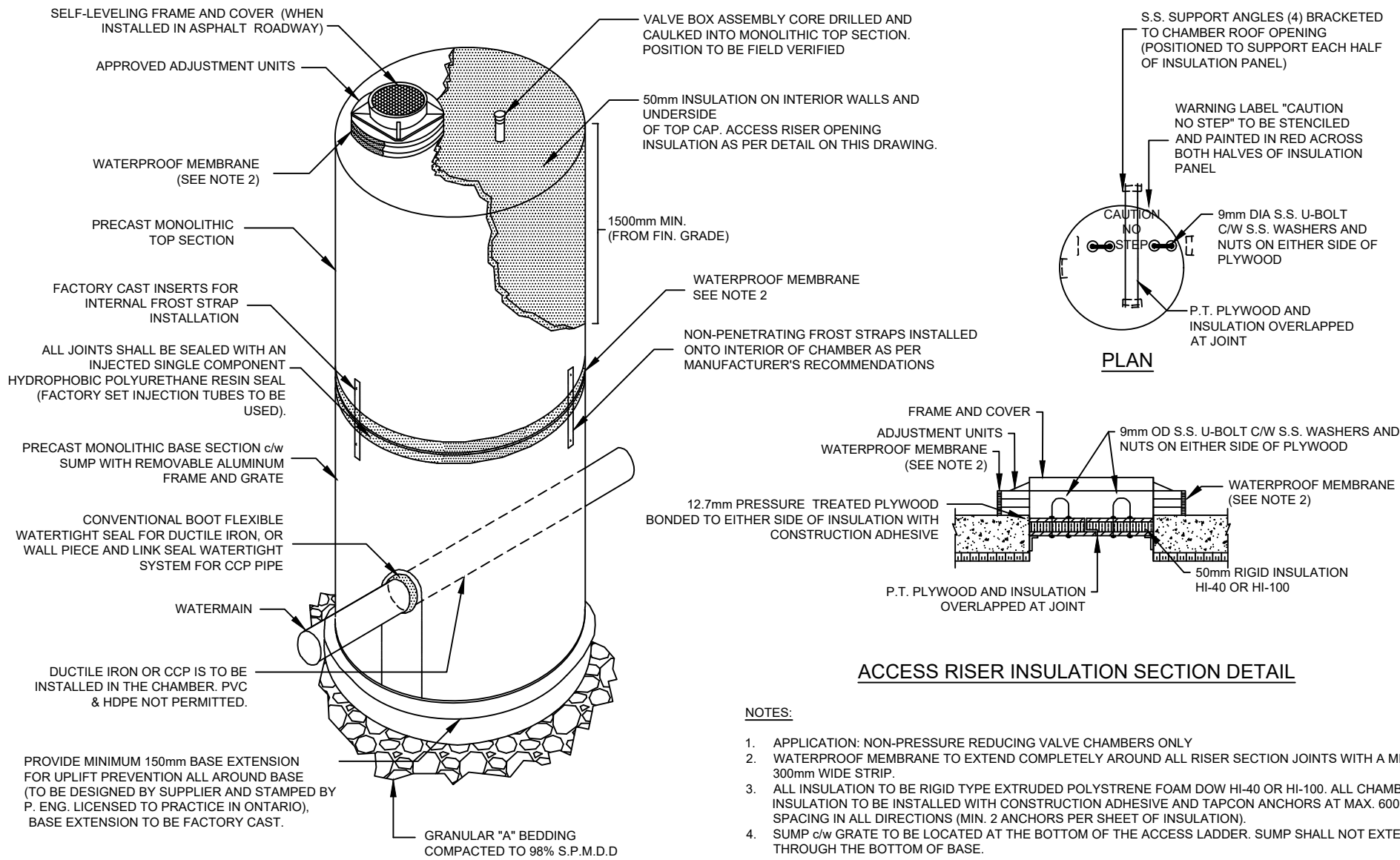

ACCESS RISER INSULATION SECTION DETAIL

NOTES:

1. APPLICATION: NON-PRESSURE REDUCING VALVE CHAMBERS ONLY
2. WATERPROOF MEMBRANE TO EXTEND COMPLETELY AROUND ALL RISER SECTION JOINTS WITH A MINIMUM 300mm WIDE STRIP.
3. ALL INSULATION TO BE RIGID TYPE EXTRUDED POLYSTYRENE FOAM DOW HI-40 OR HI-100. ALL CHAMBERS INSULATION TO BE INSTALLED WITH CONSTRUCTION ADHESIVE AND TAPCON ANCHORS AT MAX. 600mm SPACING IN ALL DIRECTIONS (MIN. 2 ANCHORS PER SHEET OF INSULATION).
4. SUMP c/w GRATE TO BE LOCATED AT THE BOTTOM OF THE ACCESS LADDER. SUMP SHALL NOT EXTEND THROUGH THE BOTTOM OF BASE.



**TYPICAL TWO PIECE
CIRCULAR CHAMBER DETAILS
FOR WATERMAIN**

APPROVED

REVISION No. DATE: MARCH 2020

SCALE: N.T.S.

MANAGER OF ENGINEERING DATE

DIRECTOR OF OPERATIONS DATE

TSD-1326

STANDARD DETAIL

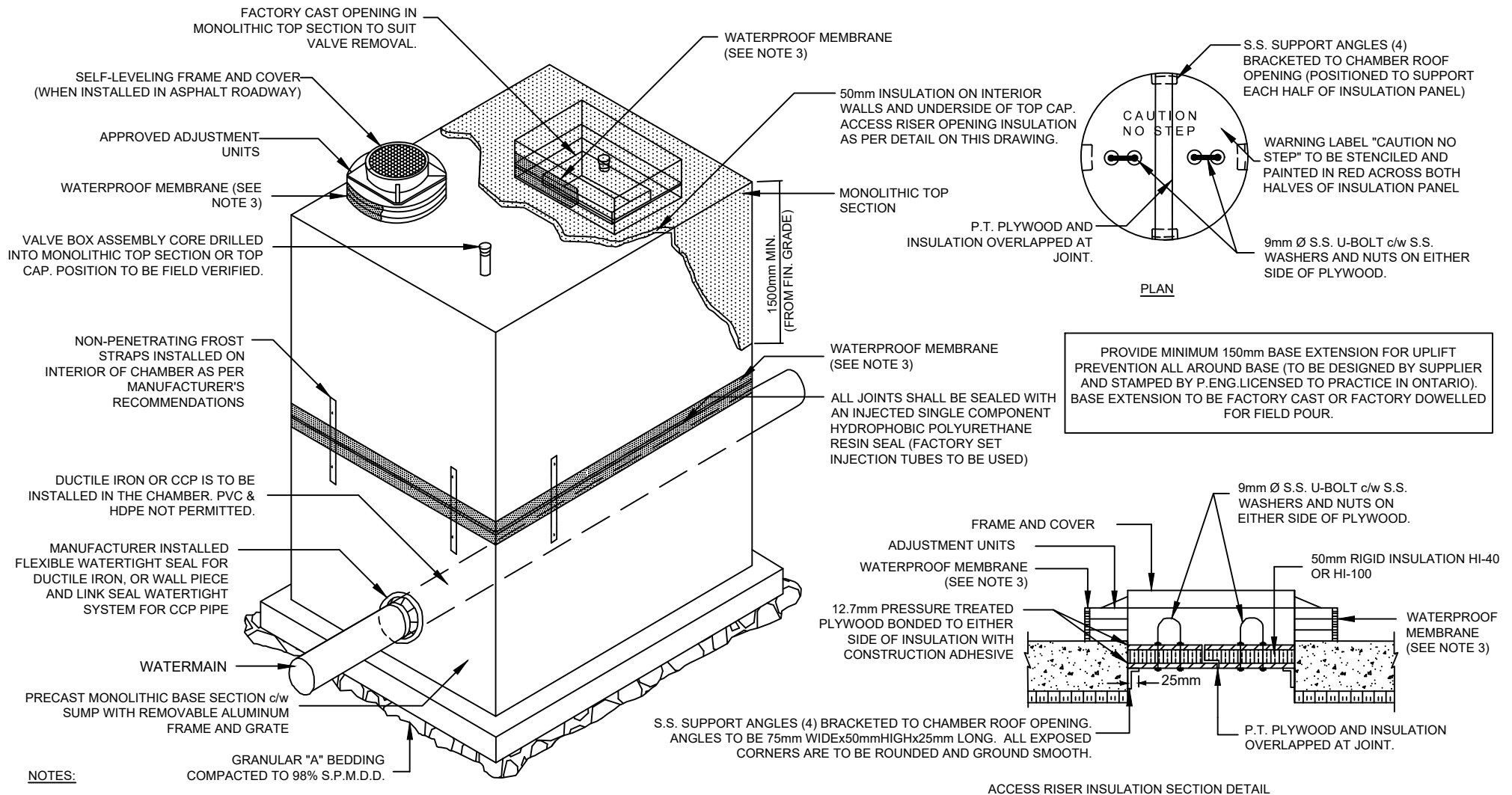

NOTES:

1. MINIMUM CHAMBER SIZE 1800mmx2400mm
2. APPLICATION:NON-PRESSURE REDUCING VALVE CHAMBERS ONLY
3. WATERPROOF MEMBRANE TO EXTEND COMPLETELY AROUND RISER SECTION JOINTS WITH A MINIMUM OF 300mm WIDE STRAP.
4. ALL INSULATION TO BE RIGID TYPE EXTRUDED POLYSTYRENE FOAM HI-40 OR HI-100. ALL CHAMBER INSULATIONS TO BE INSTALLED WITH CONSTRUCTION ADHESIVE AND TAPCON ANCHORS AT MAX. 600mm SPACING IN ALL DIRECTIONS (MIN. 2 ANCHORS PER SHEET OF INSULATION).
5. SUMP c/w GRATE TO BE LOCATED AT THE BOTTOM OF THE ACCESS LADDER. SUMP SHALL NOT EXTEND THROUGH THE BOTTOM OF BASE.



STANDARD DETAIL

TYPICAL TWO PIECE RECTANGULAR CHAMBER DETAILS FOR WATERMAIN

APPROVED

MANAGER OF ENGINEERING DATE
DIRECTOR OF OPERATIONS DATE

REVISION No. DATE: MARCH 2020

SCALE: N.T.S.

TSD-1327

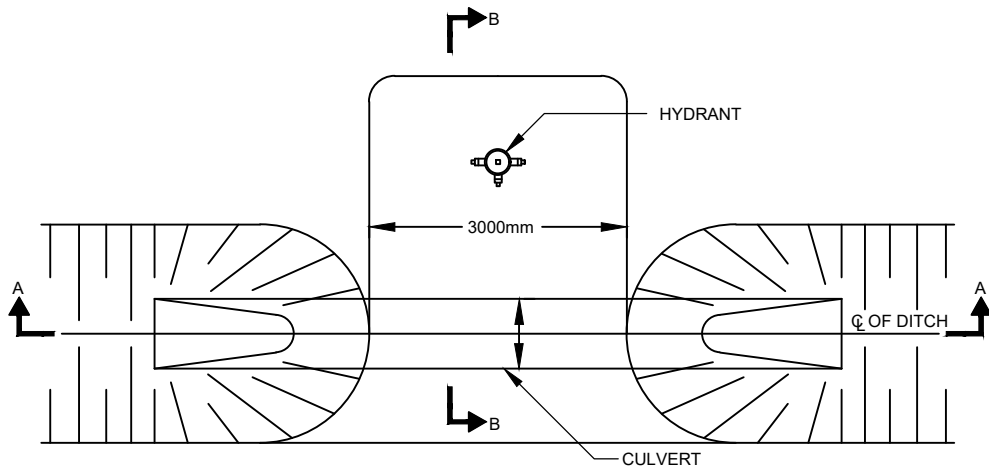

PLAN

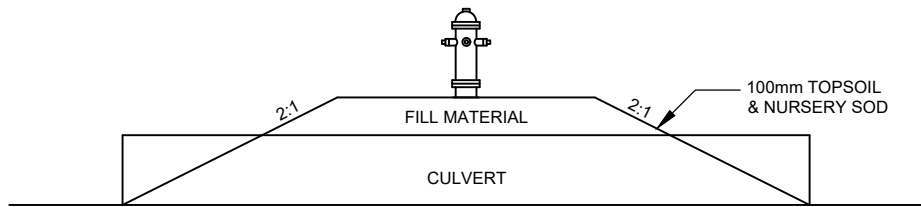

SECTION A - A

NOTES:

1. ALL DIMENSIONS ARE IN MILLIMETERS UNLESS OTHERWISE SHOWN.

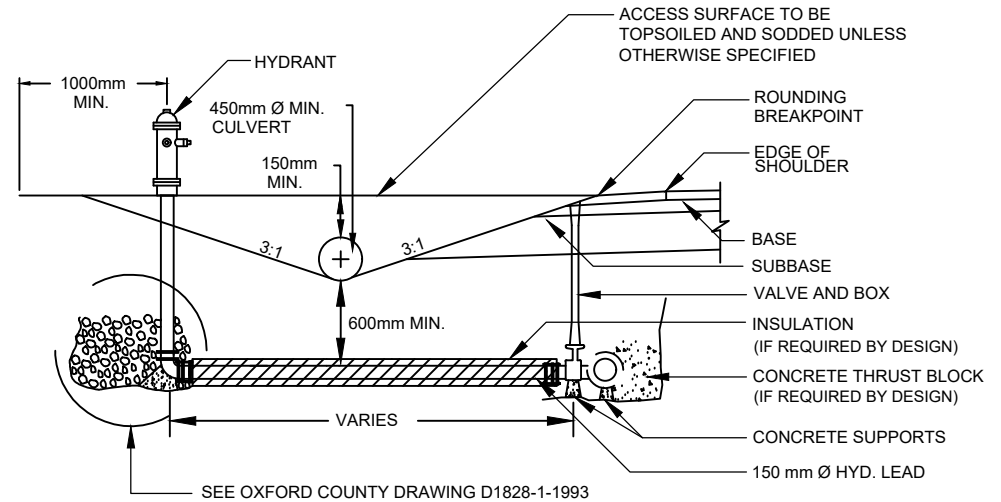

SECTION B - B



STANDARD DETAIL

HYDRANT PLATFORM DETAIL

APPROVED

MANAGER OF ENGINEERING DATE
 DIRECTOR OF OPERATIONS DATE

REVISION No. DATE: DEC 2021
 SCALE: N.T.S.

TSD-1331

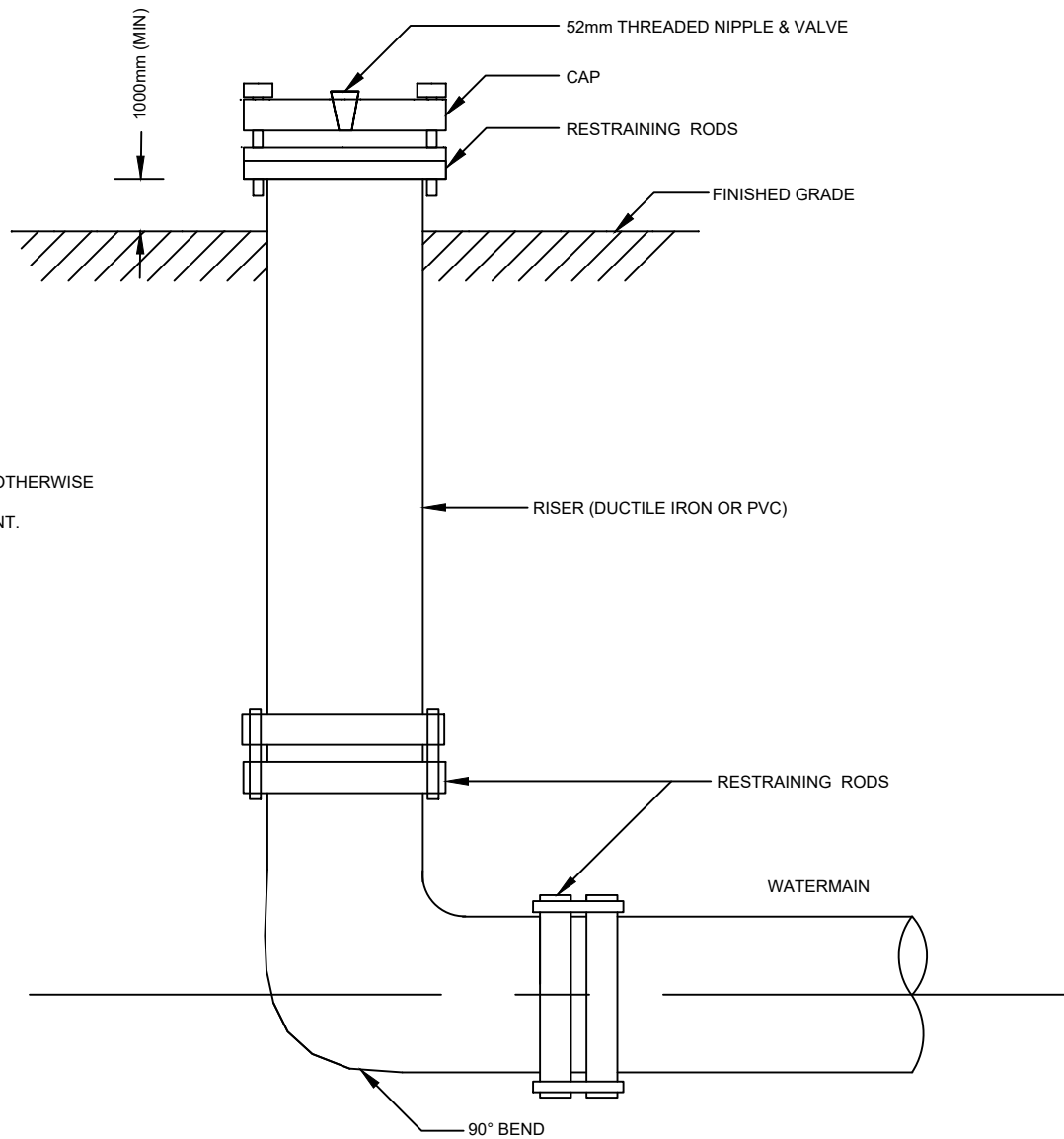

NOTES:

1. ALL DIMENSIONS ARE IN MILLIMETERS UNLESS OTHERWISE SHOWN.
2. RESTRAINING RODS TO BE USED FOR RESTRAINT.



STANDARD DETAIL

TEMPORARY RISER INSTALLATION

APPROVED

MANAGER OF ENGINEERING DATE
 DIRECTOR OF OPERATIONS DATE

REVISION No.	DATE: MARCH 2020
	SCALE: N.T.S.

TSD-1340

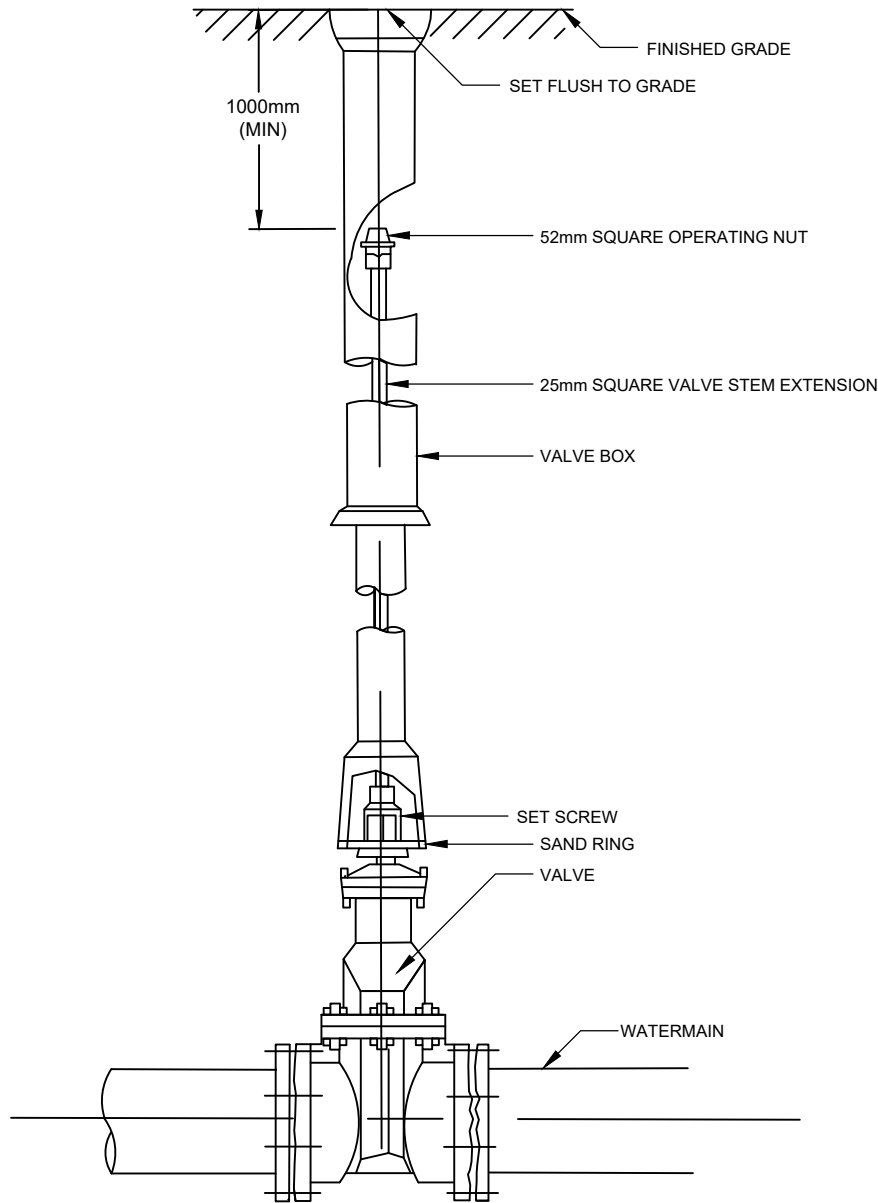

NOTES:

1. EXTENSION REQUIRED WHEN DISTANCE FROM THE TOP OF VALVE TO FINISHED GRADE IS MORE THAN 1.8m.



STANDARD DETAIL

VALVE STEM EXTENSION IN VALVE BOX

APPROVED

MANAGER OF ENGINEERING DATE
 DIRECTOR OF OPERATIONS DATE

REVISION No.	DATE: MARCH 2020
	SCALE: N.T.S.

TSD-1350

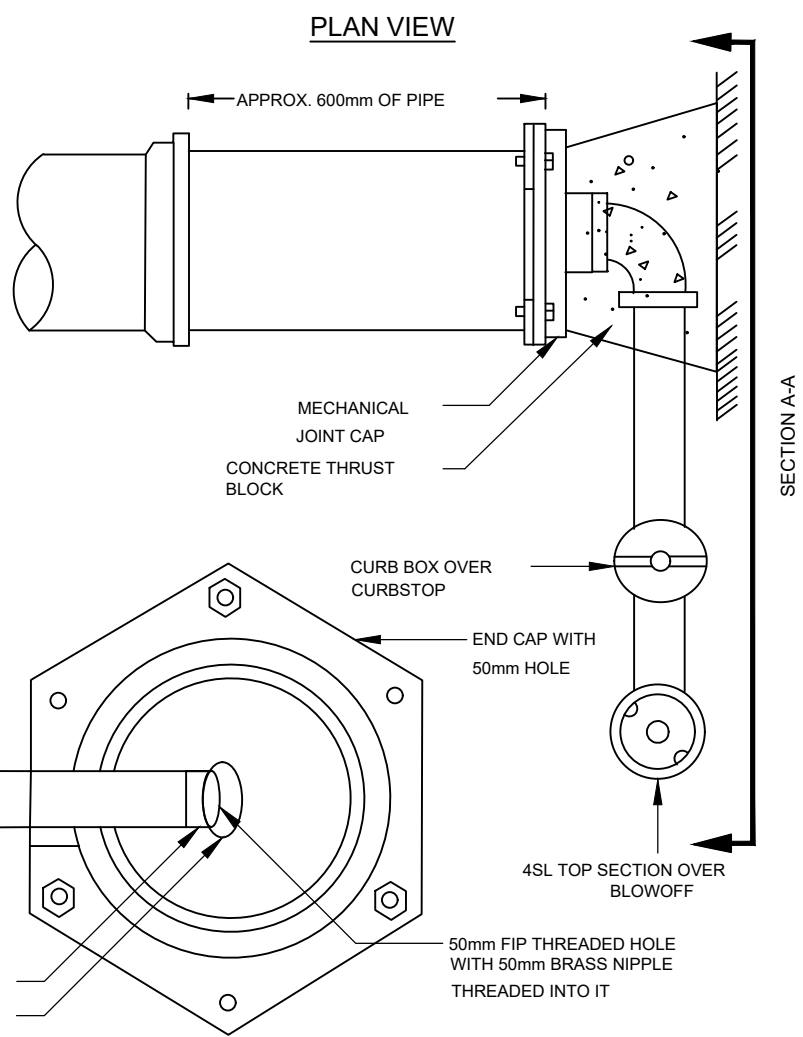
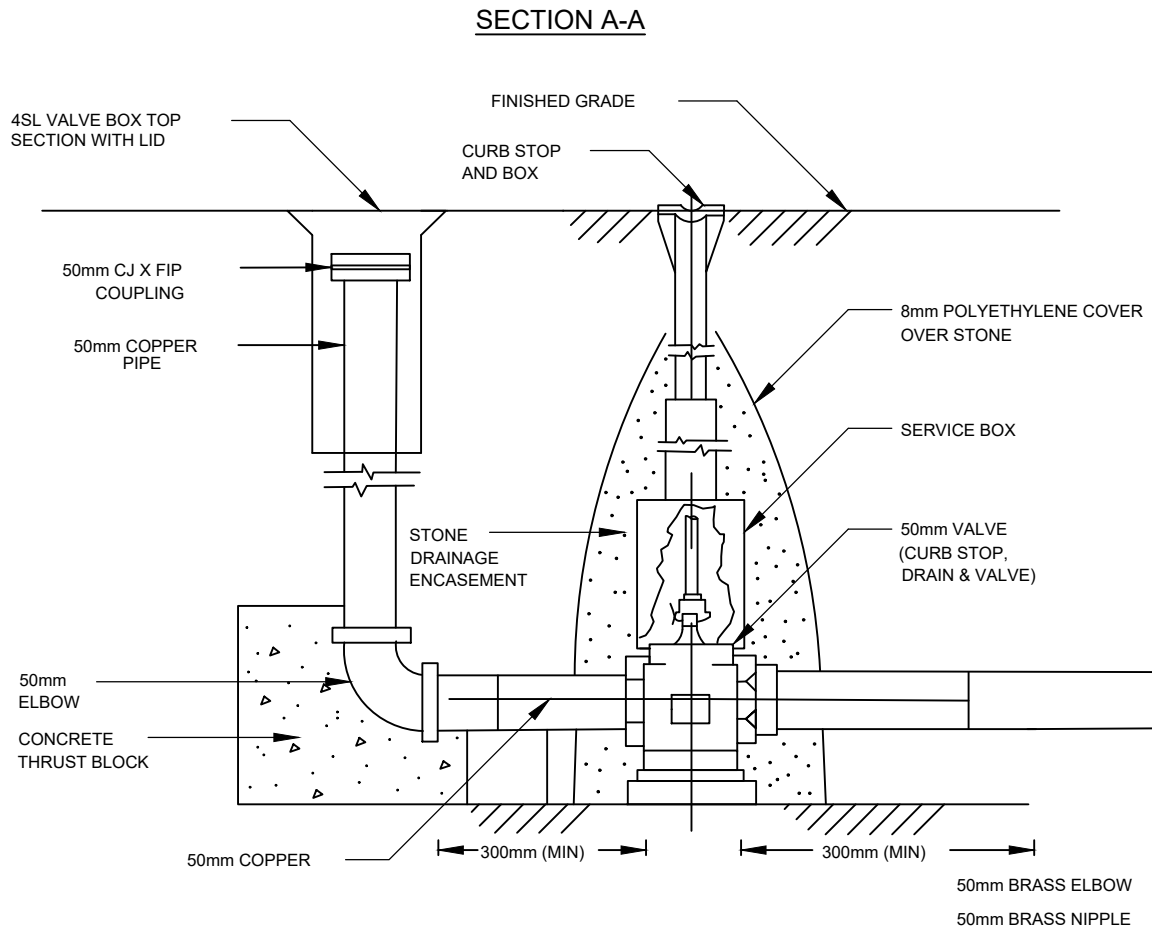

NOTES:

1. POLYETHYLENE COVER IS TO BE USED BETWEEN STONE AND BACKFILL.
2. BLOW OFFS ARE TO BE SELF DRAINING.
3. ALL DIMENSIONS ARE IN MILLIMETRES UNLESS OTHERWISE SHOWN.



STANDARD DETAIL

50mm BLOW OFF DETAIL

APPROVED

MANAGER OF ENGINEERING DATE
 DIRECTOR OF OPERATIONS DATE

REVISION No. DATE: MARCH 2020
 SCALE: N.T.S.

TSD-1360

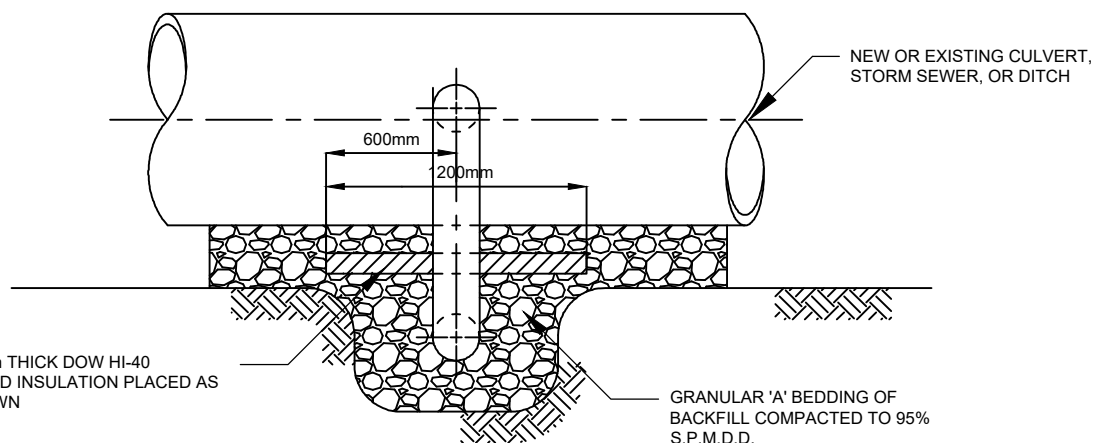
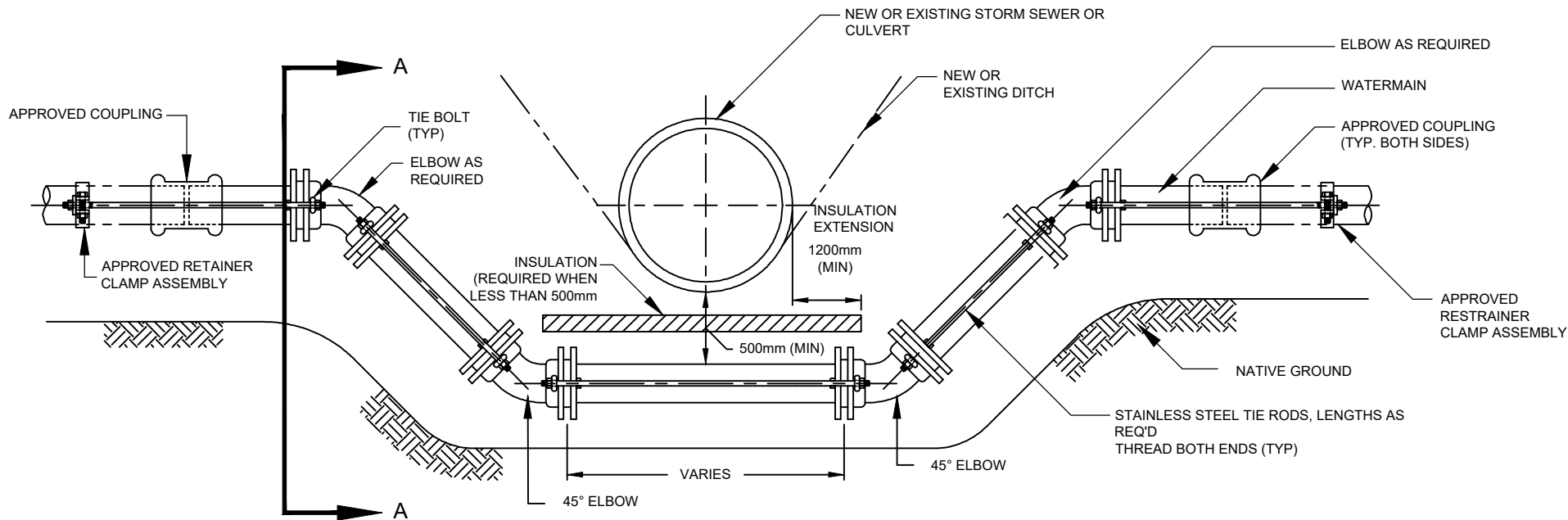

NOTES:

1. MATERIAL FOR LOWERING SHALL BE DUCTILE IRON IF EXISTING MATERIAL IS METALLIC.
2. UNITS IN MILLIMETERS UNLESS OTHERWISE NOTED.
3. THIS DETAIL IS USED FOR OFFSET ON 100, 150, & 200mm DIA MAINS. OFFSETS ON LARGER MAY REQUIRE INDIVIDUAL APPROVAL.
4. ALL JOINTS TO BE MECHANICALLY RESTRAINED, INCLUDING JOINTS ON EXISTING WATERMAIN.
5. IF OFFSET IS INSTALLED IN HORIZONTAL OR INVERTED POSITIONS, MINIMUM COVER TO BE DECIDED BY THE ENGINEER.
6. COVER TIE BOLT ASSEMBLY WITH PETROLATUM SYSTEM.
7. INSULATION MAY BE REQUIRED AS PER OXFORD COUNTY DESIGN GUIDELINES AND SPECIFICATIONS

SECTION A - A



STANDARD DETAIL

**WATERMAIN LOWERING
DETAIL FOR STORM SEWER
OR DITCH CROSSING**

APPROVED

MANAGER OF ENGINEERING DATE
DIRECTOR OF OPERATIONS DATE

REVISION No. DATE: FEB 2022
SCALE: N.T.S.

TSD-1366

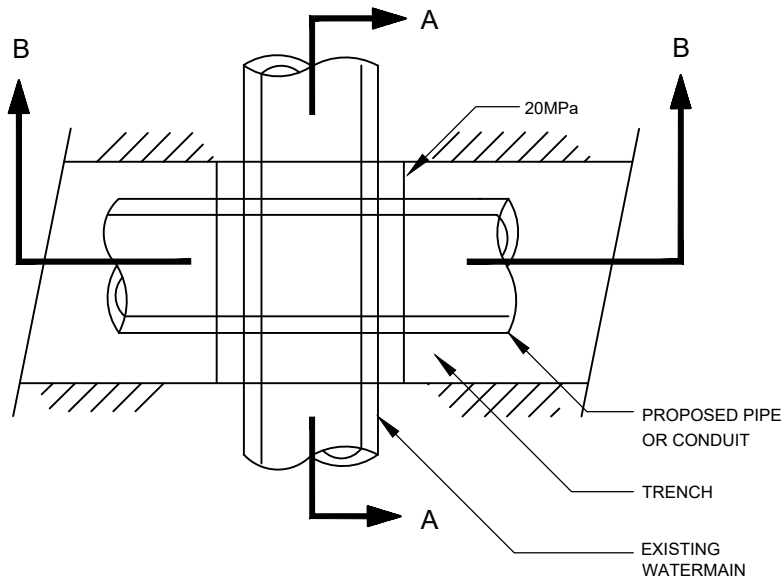

NOTES:

1. CONCRETE ENCASED MAINS SHALL BE SUPPORTED WITH CONCRETE TO UNDERSIDE OF MAIN. BOND BREAKER IS TO BE USED BETWEEN THE TWO SURFACES.
2. ALL DIMENSIONS ARE IN MILLIMETERS UNLESS OTHERWISE SHOWN.

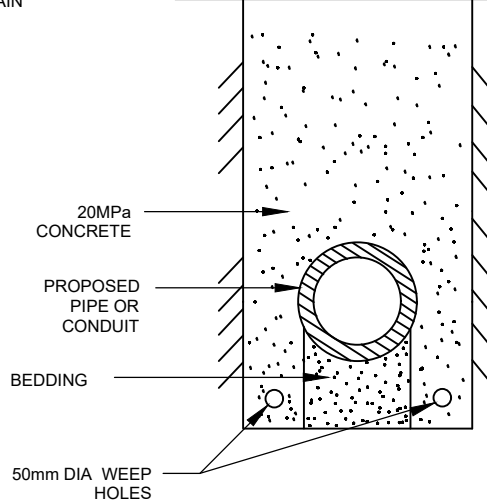
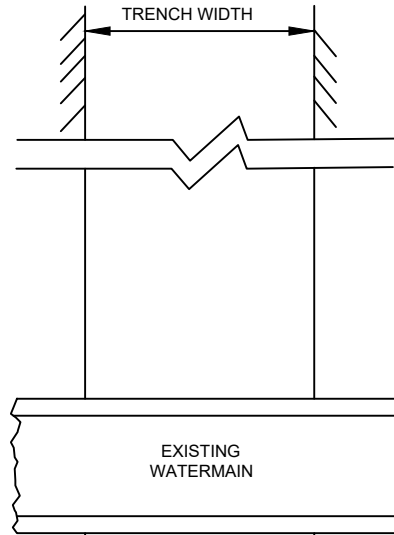

SECTION A-A

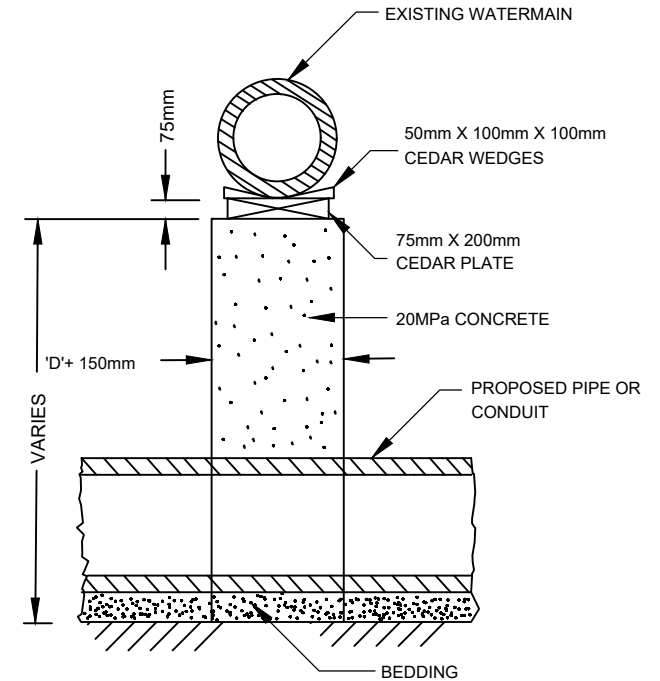
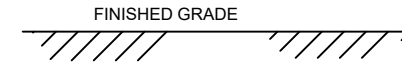

SECTION B-B



STANDARD DETAIL

**SUPPORT FOR WATERMAINS
LARGER THAN 300mm DIA.**

APPROVED

MANAGER OF ENGINEERING DATE
DIRECTOR OF OPERATIONS DATE

REVISION No. DATE: MARCH 2020
SCALE: N.T.S.

TSD-1367

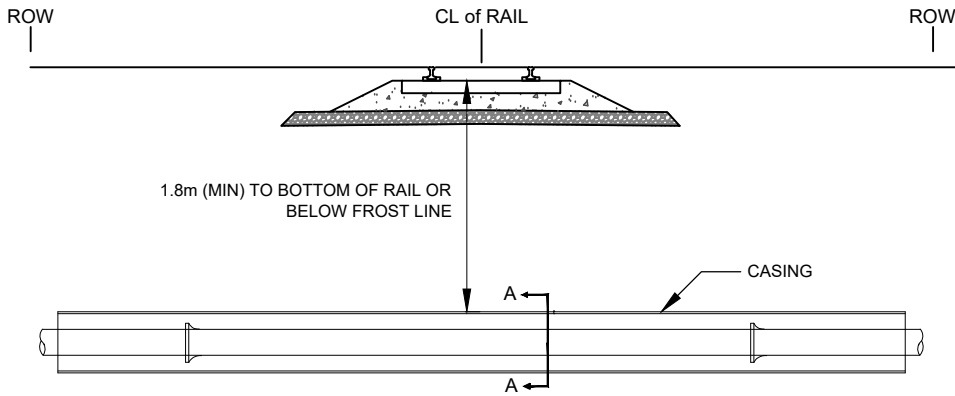

PLAN (THROUGH ROADWAY)

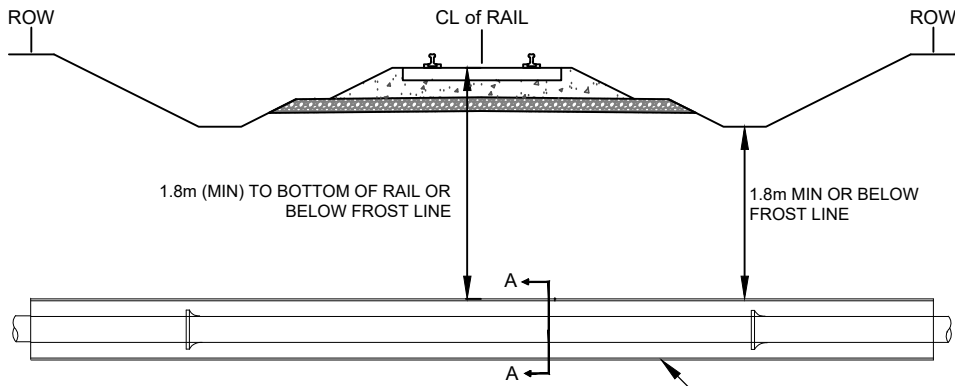

PLAN (OUTSIDE ROADWAY)

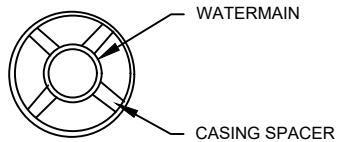

SECTION A-A

NOTES:

1. RAILWAY CROSSING DRAWINGS SHALL BE SUBMITTED TO TOWN ENGINEERING AND SHALL SHOW THE FOLLOWING INFORMATION:
 - DRAWINGS MUST BE TO SCALE AND HAVE ALL DIMENSIONS SHOWN
 - RAILWAY MILEAGE AND SUBDIVISION
 - INDICATED DIRECTION OF FLOW AND NEAREST SHUT-OFF VALVES
 - PROVIDE A PROFILE INDICATING DEPTH OF INSTALLATION
 - PROVIDE INFORMATION AS PER CHART BELOW
 - INCLUDE SECTION 'A-A', OR NOTE THAT CARRIER SHALL BE HELD CLEAR OF CASING BY PROPER SUPPORTS
 - NOTE WARNING MARKERS TO BE INSTALLED AT LIMITS OF RAIL R.O.W., AS APPLICABLE
 - NOTE PROPOSED METHOD OF INSTALLATION
 - NOTE LOCATION OF PROPOSED JACKING AND RECEIVING PITS RELATIVE TO GAUGE (INSIDE) SIDE OF NEAREST RAIL
 - INCLUDE THE CAPTION "CONSTRUCTION AND MAINTENANCE TO BE IN ACCORDANCE WITH THE CANADIAN TRANSPORTATION AGENCY GENERAL ORDER E-10"
2. ENSURE WALL THICKNESS OF CARRIER AND CASING PIPES CONFORM TO TRANSPORT CANADA REQUIREMENTS (COOPER E-90 LOADING).
3. NO EXTERNAL LOADS WILL BE TRANSMITTED TO THE CARRIER PIPE BY USE OF APPROVED PIPE LINE SPACERS.
4. DEPTH OF BURIAL FROM THE BASE OF RAIL TO BE A MINIMUM 1.8m OR BELOW THE FROST LINE.
5. CASING SHALL EXTEND THE FULL WIDTH OF THE RAILWAY R.O.W.
6. THE CASING SHALL BE INSTALLED SO AS TO PREVENT THE FORMATION OF A WATERWAY UNDER THE RAILWAY, WITH AN EVEN BEARING THROUGHOUT ITS LENGTH, AND SHALL SLOPE TO ONE END (EXCEPT FOR LONGITUDINAL OCCUPANCY).
7. THE CASING PIPE SHALL BE CONSTRUCTED AS TO PREVENT LEAKAGE OF ANY SUBSTANCE FROM THE CASING THROUGHOUT ITS LENGTH EXCEPT AT THE ENDS WHERE FREE FLOW MUST BE MAINTAINED.
8. GROUTING OF THE SPACE BETWEEN THE CARRIER AND CASING WILL NOT BE PERMITTED.
9. THE ENDS OF THE CASING PIPE SHALL NOT BE SEALED BY ANY LOAD TRANSFERRING MATERIAL.
10. SPACERS AND END SEALS SHALL FOLLOW AS PER OXFORD COUNTY'S DESIGN GUIDELINE AND SPECIFICATIONS.
11. DESIGN SHOP DRAWING REQUIRED AND SEALED BY A PROFESSIONAL ENGINEER LICENSED IN ONTARIO.
12. SITE SPECIFIC SHOP DRAWINGS REQUIRED AS PER CURRENT OCCUPATIONAL HEALTH AND SAFETY.

CASING PIPE SPECIFICATION

OUTSIDE DIA.: _____
 INSIDE DIA.: _____
 WALL THICKNESS: _____
 PIPE SPECIFICATION: _____
 LENGTH: _____
 MATERIAL: _____
 CATHODIC PROTECTION: _____

CARRIER PIPE SPECIFICATION

INSIDE DIA.: _____
 WALL THICKNESS: _____
 PIPE SPECIFICATION: _____
 MATERIAL: _____
 OPER./MAX. PRESSURE _____
 CATHODIC PROTECTION: _____



STANDARD DETAIL

WATERMAIN RAIL CROSSING
 DETAIL

APPROVED

MANAGER OF ENGINEERING DATE _____
 DIRECTOR OF OPERATIONS DATE _____

REVISION No. DATE: DEC 2021
 SCALE: N.T.S.

TSD-1368

PROFILE VIEW

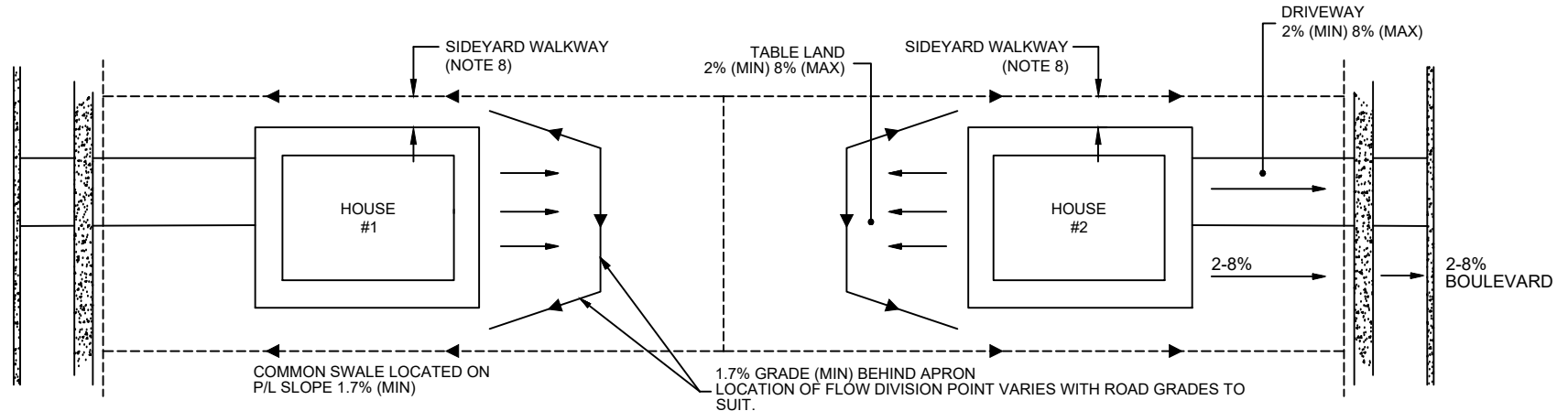
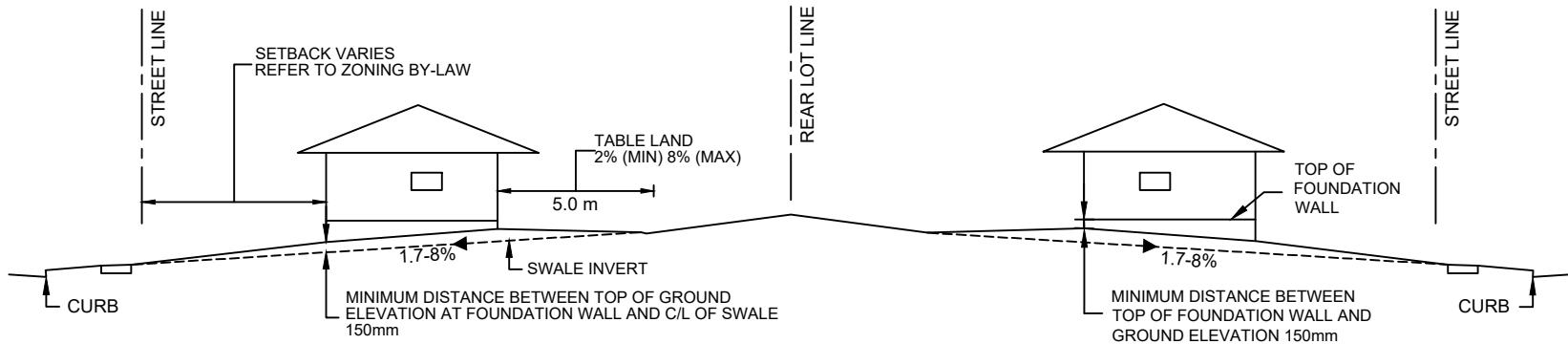

PLAN VIEW

NOTES:

1. ALTHOUGH MAXIMUM SLOPES ARE SHOWN, THEY SHOULD BE AVOIDED UNLESS NO OTHER ALTERNATIVE IS AVAILABLE.
2. THIS STANDARD IS FOR URBAN LOTS AND GENERAL IN NATURE. CERTAIN LOTS MAY REQUIRE CHANGES.
3. THIS STANDARD IS MEANT TO BE READ IN CONJUNCTION WITH THE TOWN OF TILLSONBURG LOT GRADING AND DRAINAGE STANDARDS AND DESIGN MANUAL.
4. HOUSE STYLES USED TO SUIT LOT GRADING.
5. REAR TO FRONT YARD DRAINAGE IS DISCOURAGED FOR STREET TOWNHOUSE DEVELOPMENT TO AVOID MID-YARD SWALES ACROSS THE UNITS
6. BELOW GRADE WALKOUTS AND REVERSE GRADE DRIVEWAYS WILL NOT BE PERMITTED.
7. THE REAR LOT LINE SHALL BE THE HIGH POINT OF THE LOT.
8. REFER TO TOWN OF TILLSONBURG LOT GRADING STANDARD 14.5 FOR SIDEYARD WALKWAYS.



STANDARD DETAIL

REAR TO FRONT YARD DRAINAGE

APPROVED

MANAGER OF ENGINEERING DATE
 DIRECTOR OF OPERATIONS DATE

REVISION No. DATE: FEB 2022
 SCALE: N.T.S.

TSD-1400

PROFILE VIEW

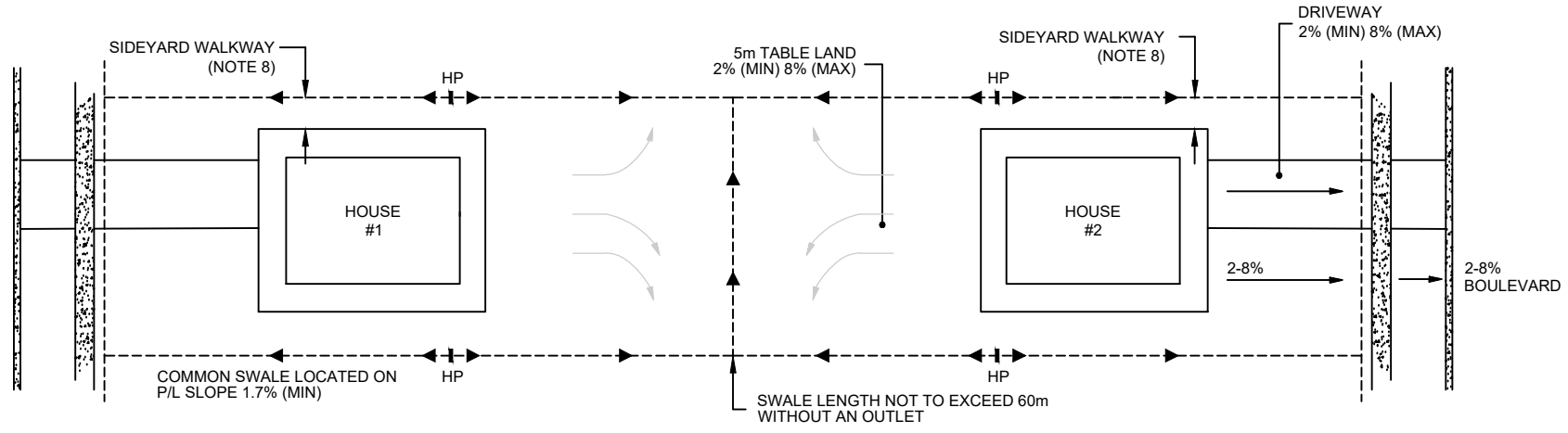
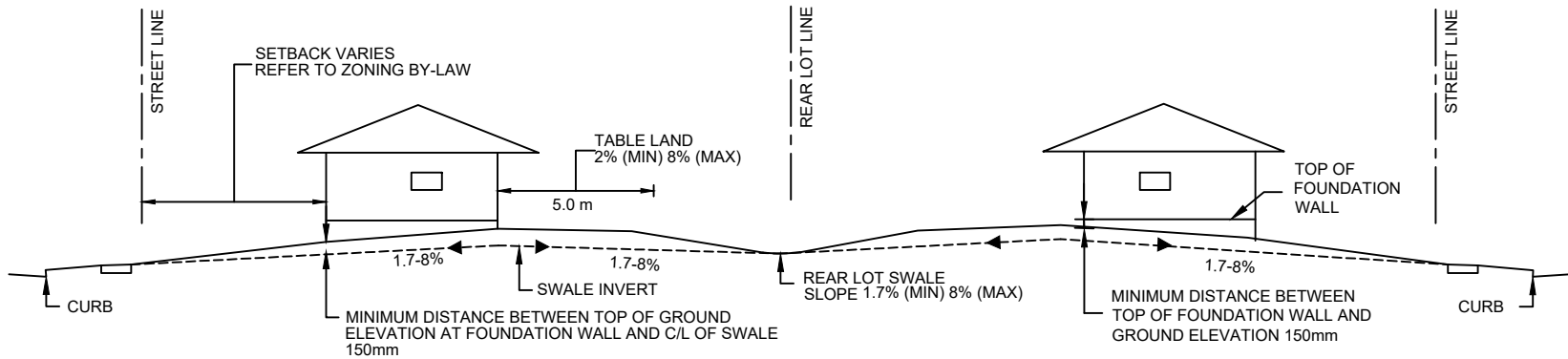

PLAN VIEW

NOTES:

1. ALTHOUGH MAXIMUM SLOPES ARE SHOWN, THEY SHOULD BE AVOIDED UNLESS NO OTHER ALTERNATIVE IS AVAILABLE.
2. THIS STANDARD IS FOR URBAN LOTS AND GENERAL IN NATURE. CERTAIN LOTS MAY REQUIRE CHANGES.
3. THIS STANDARD IS MEANT TO BE READ IN CONJUNCTION WITH THE TOWN OF TILLSONBURG LOT GRADING AND DRAINAGE STANDARDS AND DESIGN MANUAL.
4. HOUSE STYLES USED TO SUIT LOT GRADING.
5. REAR TO FRONT YARD DRAINAGE IS DISCOURAGED FOR STREET TOWNHOUSE DEVELOPMENT TO AVOID MID-YARD SWALES ACROSS THE UNITS
6. BELOW GRADE WALKOUTS AND REVERSE GRADE DRIVEWAYS WILL NOT BE PERMITTED.
7. ALL REAR LOT SWALES SHALL OUTLET TO CURBS, SIDEWALKS OR CATCHBASINS AS PER LOT GRADING AND DRAINAGE STANDARDS AND DESIGN MANUAL.
8. REFER TO TOWN OF TILLSONBURG LOT GRADING STANDARD 14.5 FOR SIDEYARD WALKWAYS.



STANDARD DETAIL

SHARED STORM EASEMENT

APPROVED

MANAGER OF ENGINEERING DATE
 DIRECTOR OF OPERATIONS DATE

REVISION No. DATE: FEB 2022
 SCALE: N.T.S.

TSD-1401

PROFILE VIEW

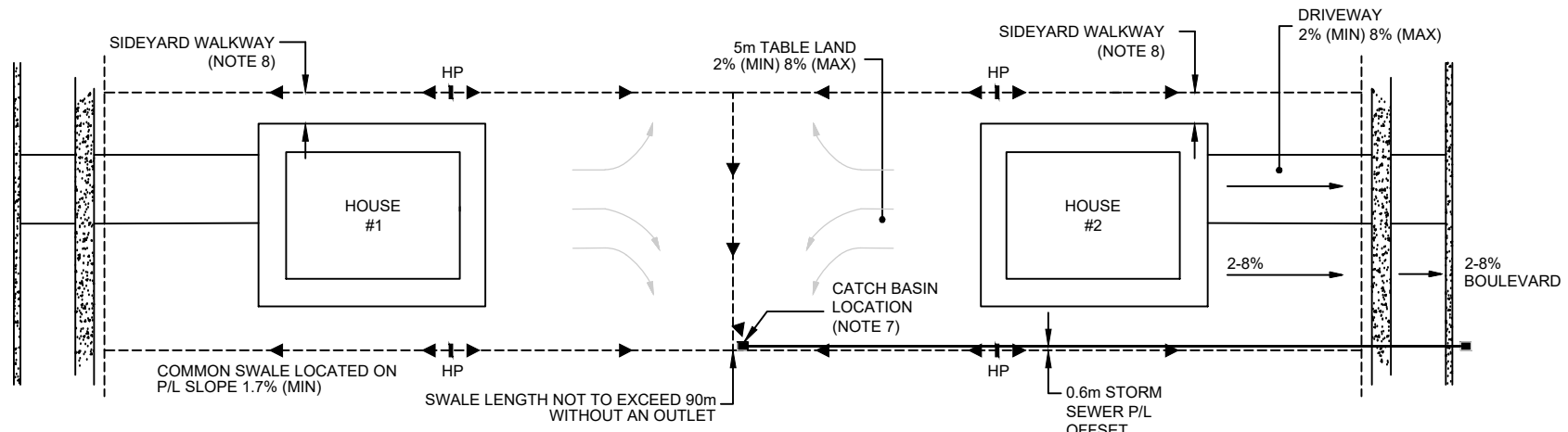
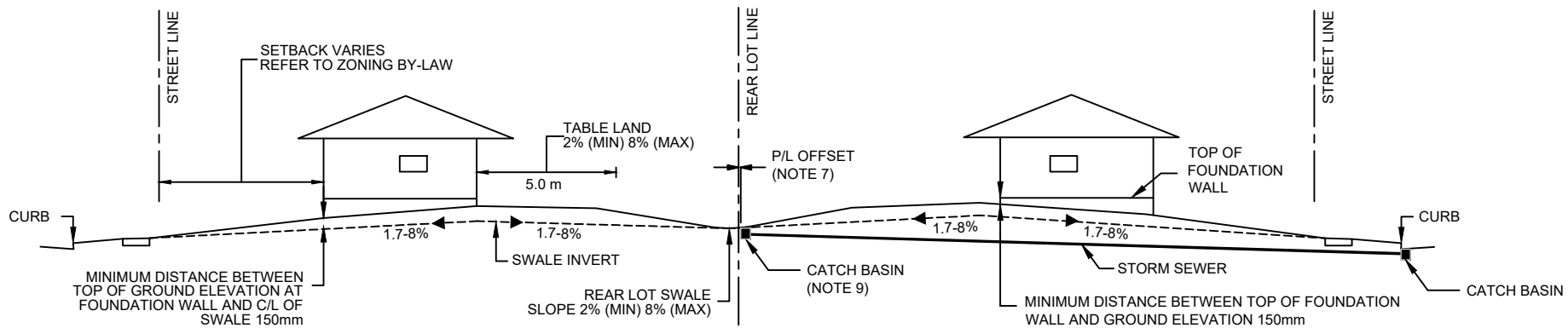

PLAN VIEW

NOTES:

1. ALTHOUGH MAXIMUM SLOPES ARE SHOWN, THEY SHOULD BE AVOIDED UNLESS NO OTHER ALTERNATIVE IS AVAILABLE.
2. THIS STANDARD IS FOR URBAN LOTS AND GENERAL IN NATURE. CERTAIN LOTS MAY REQUIRE CHANGES.
3. THIS STANDARD IS MEANT TO BE READ IN CONJUNCTION WITH THE TOWN OF TILLSONBURG DEVELOPMENT GUIDELINES AND DESIGN CRITERIA.
4. HOUSE STYLES USED TO SUIT LOT GRADING.
5. REAR TO FRONT YARD DRAINAGE IS DISCOURAGED FOR STREET TOWNHOUSE DEVELOPMENT TO AVOID MID-YARD SWALES ACROSS THE UNITS
6. BELOW GRADE WALKOUTS AND REVERSE GRADE DRIVEWAYS WILL NOT BE PERMITTED.
7. ALL REAR LOT CATCHBASIN PLACEMENT AS PER DEVELOPMENT GUIDELINES AND DESIGN CRITERIA.
8. REFER TO TOWN OF TILLSONBURG LOT GRADING STANDARD 14.5 FOR SIDEYARD WALKWAYS.
9. REAR YARD CATCHBASIN MIN. PER OPSD 705.010.
10. REAR LOT CATCH BASIN LEADS TO BE DESIGNED PER TOWN OF TILLSONBURG STORM DRAINAGE AND STORMWATER MANAGEMENT POLICIES AND DESIGN GUIDELINES.



STANDARD DETAIL

REAR YARD CATCHBASIN

APPROVED

MANAGER OF ENGINEERING DATE
 DIRECTOR OF OPERATIONS DATE

REVISION No. DATE: FEB 2022

SCALE: N.T.S.

TSD-1402

PROFILE VIEW

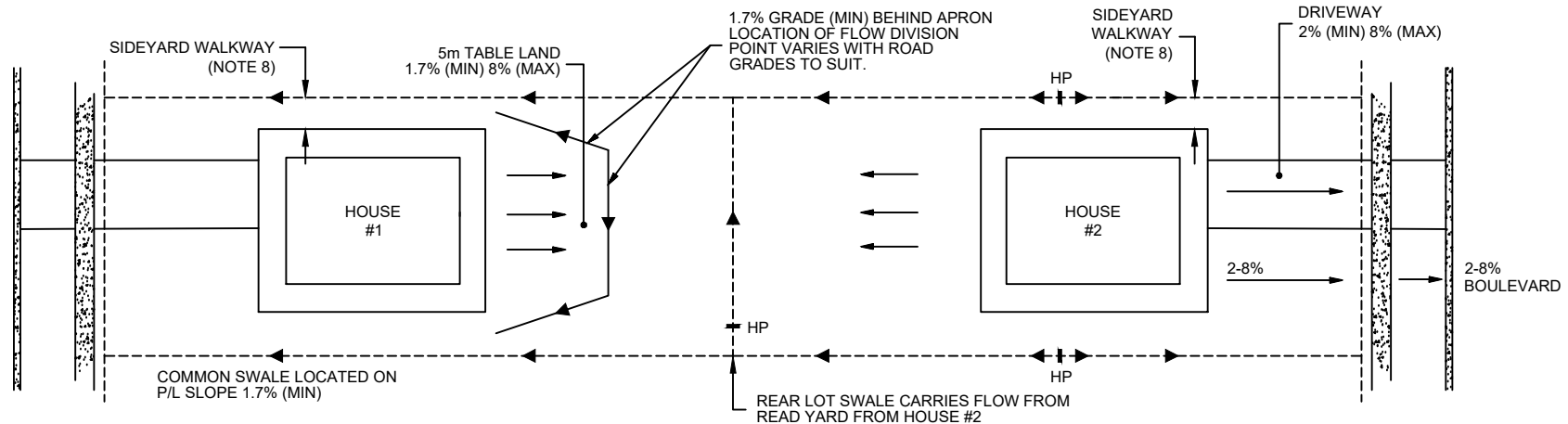
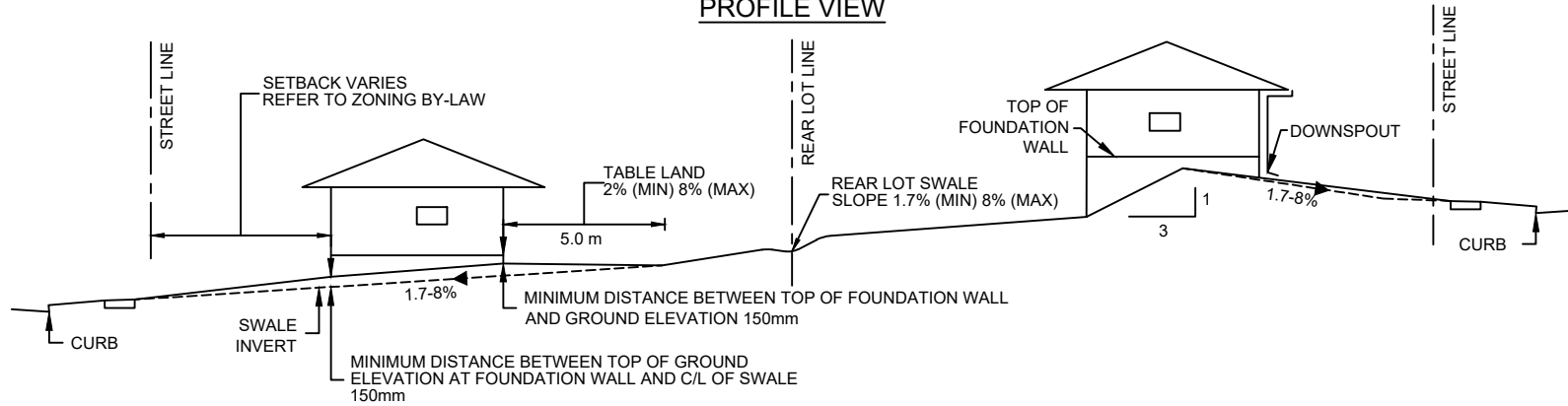

PLAN VIEW

NOTES:

1. ALTHOUGH MAXIMUM SLOPES ARE SHOWN, THEY SHOULD BE AVOIDED UNLESS NO OTHER ALTERNATIVE IS AVAILABLE.
2. THIS STANDARD IS FOR URBAN LOTS AND GENERAL IN NATURE. CERTAIN LOTS MAY REQUIRE CHANGES.
3. THIS STANDARD IS MEANT TO BE READ IN CONJUNCTION WITH THE TOWN OF TILLSONBURG'S LOT GRADING AND DRAINAGE STANDARDS AND DESIGN MANUAL.
4. HOUSE STYLES USED TO SUIT LOT GRADING.
5. REAR TO FRONT YARD DRAINAGE IS DISCOURAGED FOR STREET TOWNHOUSE DEVELOPMENT TO AVOID MID-YARD SWALES ACROSS THE UNITS
6. BELOW GRADE WALKOUTS AND REVERSE GRADE DRIVEWAYS WILL NOT BE PERMITTED.
7. GRASSED WALKWAY AS PER LOT GRADING AND DRAINAGE STANDARDS AND DESIGN MANUAL.



STANDARD DETAIL

UPPER TO LOWER LOT DRAINAGE

APPROVED

MANAGER OF ENGINEERING DATE
 DIRECTOR OF OPERATIONS DATE

REVISION No. DATE: FEB 2022
 SCALE: N.T.S.

TSD-1403

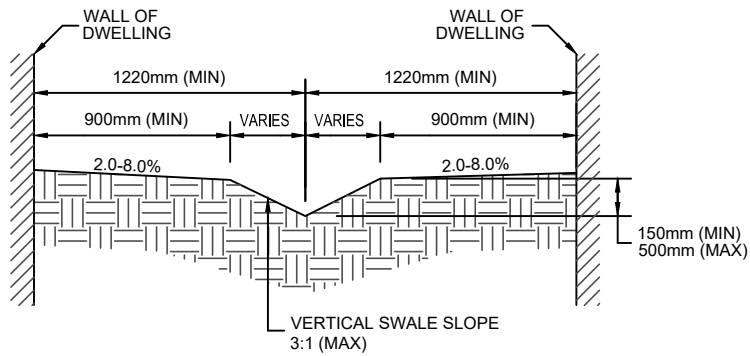

**RESIDENTIAL OFFSETS
DETACHED & SEMI-DETACHED**

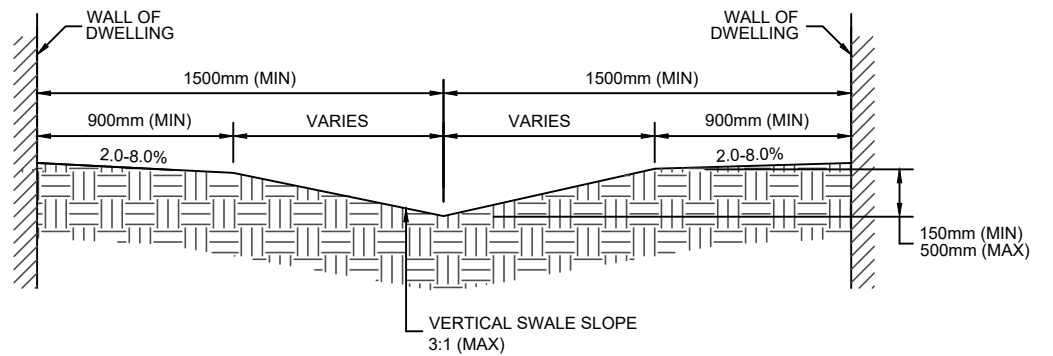

**RESIDENTIAL OFFSETS
STREET TOWNHOUSES**

NOTES

1. BUILDING OFFSETS FROM PROPERTY LINE AS PER ZONING BY-LAW.
2. THIS STANDARD IS FOR URBAN LOTS AND GENERAL IN NATURE. CERTAIN LOTS MAY REQUIRE CHANGES.
3. THIS STANDARD IS MEANT TO BE READ IN CONJUNCTIONS WITH THE TOWN OF TILLSONBURG LOT GRADING AND DRAINAGE STANDARDS AND DESIGN MANUAL.
4. HOUSE STYLES ARE TO BE USED TO SUIT LOT GRADING.
5. REAR TO FRONT YARD DRAINAGE IS DISCOURAGED FOR STREET TOWNHOUSE DEVELOPMENT TO AVOID MID-YARD SWALES ACROSS THE UNITS.
6. BELOW GRADE WALKOUTS AND REVERSE GRADED DRIVEWAYS WILL NOT BE PERMITTED.



STANDARD DETAIL

**TYPICAL SIDE YARD
DRAINAGE**

APPROVED

MANAGER OF ENGINEERING DATE
DIRECTOR OF OPERATIONS DATE

REVISION No. DATE: FEB 2022
SCALE: N.T.S.

TSD-1404



Appendix "B"
Town of Tillsonburg Design Sheet

