



## **Section 11**



## Table of Contents

<b>11</b>	<b>STORMWATER MANAGEMENT</b>	<b>1</b>
11.1	General Requirements	1
11.2	Reference Documents	1
11.3	Objectives	1
11.3.1	Stormwater Quantity Objectives	2
11.3.2	Stormwater Quality Objectives	2
11.4	Water Balance	2
11.5	Low Impact Development	3
11.6	Municipal Drain Considerations	3
11.7	Requirements for Stormwater Management Report	3
11.8	Stormwater Model Guidelines	4
11.9	Rainfall Design Storms	4
11.10	Stormwater Management Pond Design Criteria	5
11.10.1	Inlet and Outlet Structures	5
11.10.2	Maintenance Access Roads	5
11.10.3	Sediment Drying Area	5
11.10.4	Slopes and Embankments	6
11.10.5	Emergency Overflow Spillway	6
11.10.6	Overland Flow Routes	6
11.10.7	Orifice Size	6
11.10.8	Vegetation and Plantings	6
11.11	Requirements for Erosion and Sediment Control During Construction	7
11.12	Commissioning Considerations	8
11.12.1	Maintenance and Monitoring Prior to Assumption	8
11.12.2	Operation Prior to Assumption	8
11.12.3	Operation and Maintenance Manual	8

## List of Tables

Table 1. IDF Design Parameters

## **11 STORMWATER MANAGEMENT**

### **11.1 General Requirements**

This section covers the recommended approach for the design, analysis and implementation of the stormwater management (SWM) systems for residential, commercial, institutional and industrial developments within the Town of Tillsonburg. The purpose of this section is to outline the recommended criteria for stormwater management system design that will ultimately be assumed by the Town and should be read in conjunction with Section 10 – Storm Sewers.

Prior to initiating the preparation of the stormwater management, the Proponent must consult with the Long Point Region Conservation Authority (LPRCA) and the Town of Tillsonburg on the stormwater management criteria that shall be utilized in the design and analysis of the development. Criteria issued by these agencies shall be applied to the design of the SWM system.

Detailed stormwater design sheets are to be included in all subdivision and site plan development applications.

### **11.2 Reference Documents**

All stormwater management systems shall be designed and constructed in accordance with the latest version of this manual, as well as other industry standards and best practices, including but not limited to:

- Ontario Provincial Standard Specifications (OPSS) and Ontario Provincial Standard Drawings (OPSD) prepared by the Ministry of Transportation (MTO)
- Stormwater Management Planning and Design Manual (current revision – 2003) prepared by the Ministry of the Environment Conservation and Parks (MECP)
- Erosion and Sediment Control Guidelines for Urban Construction (current revision – 2006) prepared by the Greater Golden Horseshoe Area Conservation Authorities
- The Low Impact Development Stormwater Management Planning and Design Guide prepared by the Toronto and Region and Credit Valley Conservation Authorities

### **11.3 Objectives**

The stormwater management system for each development shall satisfy the following objectives:

1. Ensure compliance with all applicable Town requirements, standards, provincial guidelines
2. Maintain and promote low impact, sustainable stormwater management for the expanding urban system

3. Ensure implementation of safe, environmentally conscience, easily maintained, and cost-effective stormwater management facilities

### **11.3.1 Stormwater Quantity Objectives**

A distinction shall be made between developments within a new planning area and those developments occurring established neighbourhood. The distinction shall be made by the Town of Tillsonburg in conjunction with other regulatory agencies, such as the LPRCA.

The stormwater management design for developments within new planning areas shall implement the recommendations of the pre-consultation with LPRCA and the Town of Tillsonburg. Typically, the development shall be required to control all post-development flows to the corresponding pre-development flow rates (greenfield) unless otherwise stated in a previously completed subwatershed master plan. Should the development fall within a subwatershed master plan, the development shall control flows according to the allocated flows specified.

The stormwater management system design for developments occurring in an established neighbourhood shall control all post-development flows to the corresponding pre-development flow rate unless the lands have already been included in existing completed downstream SWM facilities, or as otherwise directed by the Town or LPRCA. The site must be designed to detain sufficient volumes on-site in order to ensure that post-development peak flow rates do not exceed pre-development flow rates for the same design storm events, and to ensure existing downstream infrastructure and conveyance systems are not surcharged, resulting in flooding and significant damages.

All developments shall be designed to safely convey overland flows to an adequate outlet.

### **11.3.2 Stormwater Quality Objectives**

For all residential, commercial, institutional and industrial developments, the Town requires Enhanced Water Quality Protection (80% Total Suspended Solids Removal) as described in the Stormwater Management Planning and Design Manual prepared by the MOE (2003) prior to discharge from the site to the receiving outlet.

Where there is a potential for spill contamination, developments are to provide an appropriate containments and pretreatment prior to discharging from the site to a stormwater management facility. Only “clean” runoff shall be allowed to be infiltrated.

Should the development be located within a Source Water Protection Zone, consultation with LPRCA, Oxford County and the Town will be required prior to design of any infiltration systems.

## **11.4 Water Balance**

Best Management Practices recommend that post-development groundwater recharge rates replicate pre-development rates within new urban development. Groundwater recharge shall only occur however in areas deemed appropriate by the Town, Oxford County, LPRCA, and MECP.

A site-specific water balance calculation shall be completed using the water balance method as documented in the MOE's Stormwater Management Planning and Design Manual. Infiltration facilities shall be designed to ensure that the annual infiltration volume for the post-development condition matches the volume for the pre-development condition.

### **11.5 Low Impact Development**

The Town encourages innovative use of Low Impact Development (LID) devices for stormwater management systems both for new development and infill/brownfield re-developments where feasible. LID practices include the incorporation of "green infrastructure" such as infiltration basins, green roofs, bioretention swales, and other conveyance swale methods within the municipal stormwater management facility as well as specific installations within stormwater facility block.

The installation and implementation of LID systems within the stormwater facility block shall be subject to consultation and approval with the Town (and County if applicable) prior to approval and installation. These LID systems are to be low maintenance and cost-effective. The Developer shall provide an estimated maintenance cost schedule analysis for the lifetime of the proposed LID system to the Town.

Draft Operations and Maintenance manuals for any LID systems that the Town will assume shall be provided to the Town for review prior to approval.

Should the development fall within Source Water Protection Zones, consultation with LPRCA, Oxford County and the Town will be required prior to design of LID systems.

### **11.6 Municipal Drain Considerations**

Stormwater management systems that outlet to a municipal drain shall control the allowable run-off rates from the development to the specified allotted run-off or contributing flow in the most recent version of the municipal drainage report.

Should the municipal drain outlet prove to be insufficient, the consultant shall follow the appropriate process as outlined in the Municipal Drainage Act to establish a sufficient outlet.

In situations where stormwater is to outlet to a municipal drain, consultation with the Town and LPRCA will be required prior to the design of the system.

### **11.7 Requirements for Stormwater Management Report**

The requirements for quantity and quality control of stormwater run-off management and supporting report or criteria shall be assessed on an individual project basis.

Design concepts for stormwater management facilities and designs will generally (after consultation with the Town of Tillsonburg, and LPRCA) follow the reference documents listed above and shall be subject to the above-mentioned review agencies.

Generally, all Stormwater Management Reports are to include:

- Reports must be signed and sealed by a Professional Engineer in accordance with the Professional Engineers Ontario “Use of the Professional Engineer’s Seal Guideline.”
- SWM designs may incorporate innovative approaches, provided the intent of the SWM system requirements and criteria are achievable and sustainable.
- Shall establish the minor-major storm event drainage concept for the development and shall demonstrate the ultimate outlet for the development.
- SWM designs to include flow calculations (Flow and Max Depth) of all overland drainage areas, rear yard swales, and any significant drainage feature.
- The water balance evaluation and calculations shall include an assessment of existing conditions and recommended measures to mitigate the impact to the water balance under post development conditions.
- The report shall establish defined pre and post development catchment areas with the following parameters: Soil type, corresponding soil number used in hydraulic equations, land coverage type, previous and future use, overall slope and how each catchment relates to each other. This will also be accompanied with a catchment area drawing for pre and post development.

### **11.8 Stormwater Model Guidelines**

For all developments, hydraulic models may be required by the Town.

OTTHYMO, PC-SWMM, Autodesk Storm and Sanitary Analysis (SSA), and Visual OTTHYMO are the simulation models preferred by the Town of Tillsonburg; however, other models may be acceptable to the Town.

### **11.9 Rainfall Design Storms**

For stormwater management system design and modelling the design storms shall be a 3-hour Chicago-type storm distribution based on the IDF curves below.

The Regional Storm event to be used shall be Hurricane Hazel (1954).

**Table 1: IDF Design Parameters**

Parameter	Rainfall Intensity (mm/h)					
	2 Year	5 Year	10 Year	25 Year	50 Year	100 Year
A	21.4	28.3	32.8	38.5	2.7	46.9
B	-0.675	-0.662	-0.656	-0.651	-0.647	-0.645

## 11.10 Stormwater Management Pond Design Criteria

### 11.10.1 Inlet and Outlet Structures

Inlet and outlet structures shall be designed for ease of maintenance. The inlet and outlet structures shall be designed to prevent debris and the public from entering the structures.

Inlet structures shall be installed to match the designed water levels and shall include a headwall or pipe structure as per OPSD 804 Series. Appropriate sized and designed erosion protection shall be provided to prevent erosion and scouring. The protection shall be the full width of the inlet and outlet structure and shall be selected to withstand the anticipated velocities.

### 11.10.2 Maintenance Access Roads

Maintenance access roads shall be required from the municipal right of way to all aspects of the SWM facility, specifically the inlet structure, outlet structure and the sediment forebays. Dead end maintenance access roads shall not be installed unless approved by the Town for site specific restrictions.

The maintenance roads shall be a minimum of 3.5m in width. The cross fall for the access road shall be 2% - 4% with a longitudinal gradient between 2% - 6%.

The access connecting the SWM facility from the ROW shall be a minimum of 6.0m in width.

The maintenance access road shall incorporate suitable turning radii for Town vehicles and shall have an asphalt surface A Geotechnical Engineer to provide granular and asphalt structure.

### 11.10.3 Sediment Drying Area

A sediment drying area shall be provided immediately adjacent to the maintenance access road and to the sediment forebay to facilitate ease of access for sediment removal from the forebay and sediment storage. The area should be graded to allow positive drainage to the forebay at a minimum slope of 2.0%. The sediment drying area shall be designed to facilitate the volume required for maintenance at 10 years. The drying area shall be rehabilitated at the time of maintenance.

#### **11.10.4 Slopes and Embankments**

Slopes and embankments shall compile with Stormwater Management Planning and Design Manual (MOE, 2003) and shall be sloped in order to protect the public.

#### **11.10.5 Emergency Overflow Spillway**

All SWM systems shall be designed with an emergency overflow spillway where applicable to allow for the safe storm drainage without impacting adjacent landowners in the event of a failure of the outlet structure or a storm event that exceeds the pond design.

The spillway shall maintain 0.3m of freeboard to the top of the facility perimeter berm under the regional design storm event. The invert of the spillway shall be set at the maximum ponding elevation obtained at the regional design storm event.

Erosion protection at the spillway shall be installed and sized to protect the structure from erosion during the regional event. The consultant shall ensure that the erosions protection is suitable for the anticipated velocities under the Regional design storm event.

#### **11.10.6 Overland Flow Routes**

Major overland flow should not be directed into the sediment forebay wherever possible to avoid resuspension of sediment.

Erosion protection at the spillway shall be installed and sized to protect the spillway from erosion during the regional design storm event. The consultant shall ensure that the erosion protection is suitable for the anticipated velocities during the regional design storm event.

Drying area not to be included in the Overland Flow Route.

#### **11.10.7 Orifice Size**

The preferred minimum orifice size acceptable for outlet control is 100mm diameter to prevent clogging.

All orifices devices shall be manufactured from non-corrosion material and shall be installed securely to the structure.

#### **11.10.8 Vegetation and Plantings**

Vegetation and Plantings for the SWM facility shall be selected by a licensed landscape architect and shall submit the proposed planting design drawing complete with species to the Town for approval.

The plantings within the SWM facility shall be all native species, ecologically selected and low maintenance. The perimeter of the SWM facility shall be native wild flowers as per Long Point Region Conservation Authority with the exclusion of Golden Rod .



No noxious weeds or plants shall be accepted within the proposed planting plan.

### **11.11 Requirements for Erosion and Sediment Control During Construction**

The SWM report shall include the list of items below in terms of controlling erosion and the transport of sediment into natural watercourses during construction. However, since the list is intended to cover a broad range of development proposals, portions of the submission list may not be applicable for all development proposals.

- Erosion and Sediment Control Plans
- Erosion and Sediment Control Phasing
- Worksite Isolation Plan for In-stream Construction
- Spill Control and Response Plan
- De-watering plan
- Storm Drain Outfall Protection
- Storm Drain Inlet Protection
- Seeding/Sodding
- Sediment/Silt Control Fence
- Interception/Diversion Swales and Dykes
- Vehicle Tracking Control/Mud Mats
- Sediment Traps
- Rock Check Dams
- Temporary Sediment Control Ponds/Basins
- Topsoil Stockpiles
- Construction Access Mud Mats
- Restoration

## **11.12 Commissioning Considerations**

### **11.12.1 Maintenance and Monitoring Prior to Assumption**

Maintenance and monitoring of the SWM facility prior to the Town's assumption shall be carried out by the Developer to demonstrate the effectiveness of the performance of these facilities in accordance with the approved Environmental Compliance Approval (ECA). The proposed maintenance and monitoring plan shall be submitted to the Town prior to construction for review and approval.

The maintenance and monitoring and associated costs shall be the sole responsibility of the Developer until assumption by the Town.

Proportional cost sharing for maintenance and monitoring of the SWM facility will be evaluated amongst the benefiting developments on an individual case by case basis.

### **11.12.2 Operation Prior to Assumption**

The Developer shall be responsible for the operation and maintenance of the SWM facility prior to assumption.

Prior to assumption the Developer shall be responsible for the dredging and removal of all sediment as a result of operation and construction activities. In addition, the Developer shall be responsible for the removal of any temporary protection measures installed for construction activities.

### **11.12.3 Operation and Maintenance Manual**

Prior to assumption, the Developer shall submit an Operations and Maintenance Manual for the stormwater management facility to the Town for review and approval. This document shall detail typical operation and maintenance procedures to maintain a functional pond, including a detailed clean out procedure.

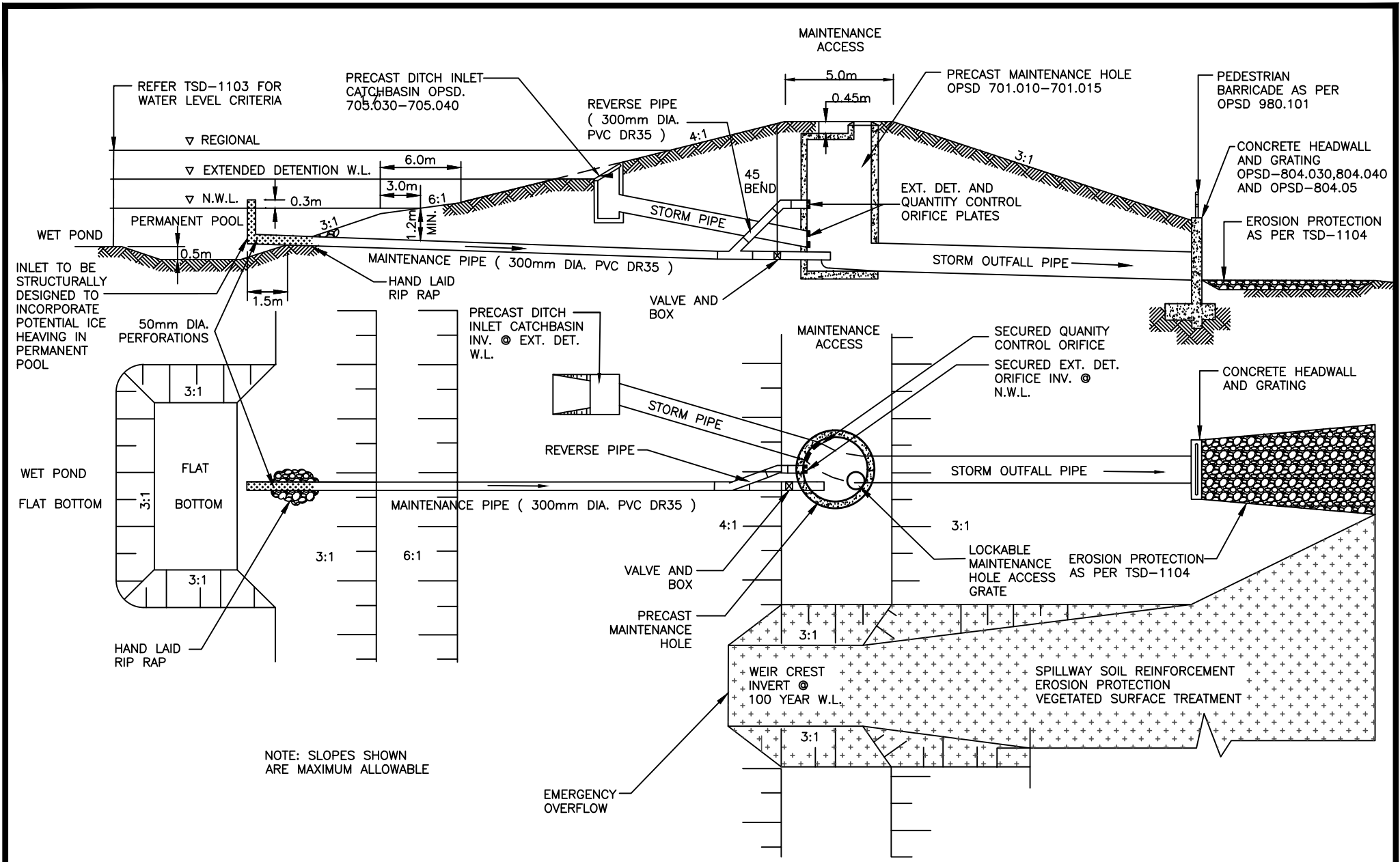

# OUTLET STRUCTURE TYPICAL DETAIL WET POND FACILITY WITH MAINTENANCE PIPE

**APPROVED**

REVISION No. DATE: FEB 2022

SCALE: N.T.S.

STANDARD DETAIL

MANAGER OF ENGINEERING DATE

DIRECTOR OF OPERATIONS DATE

**TSD-1100**

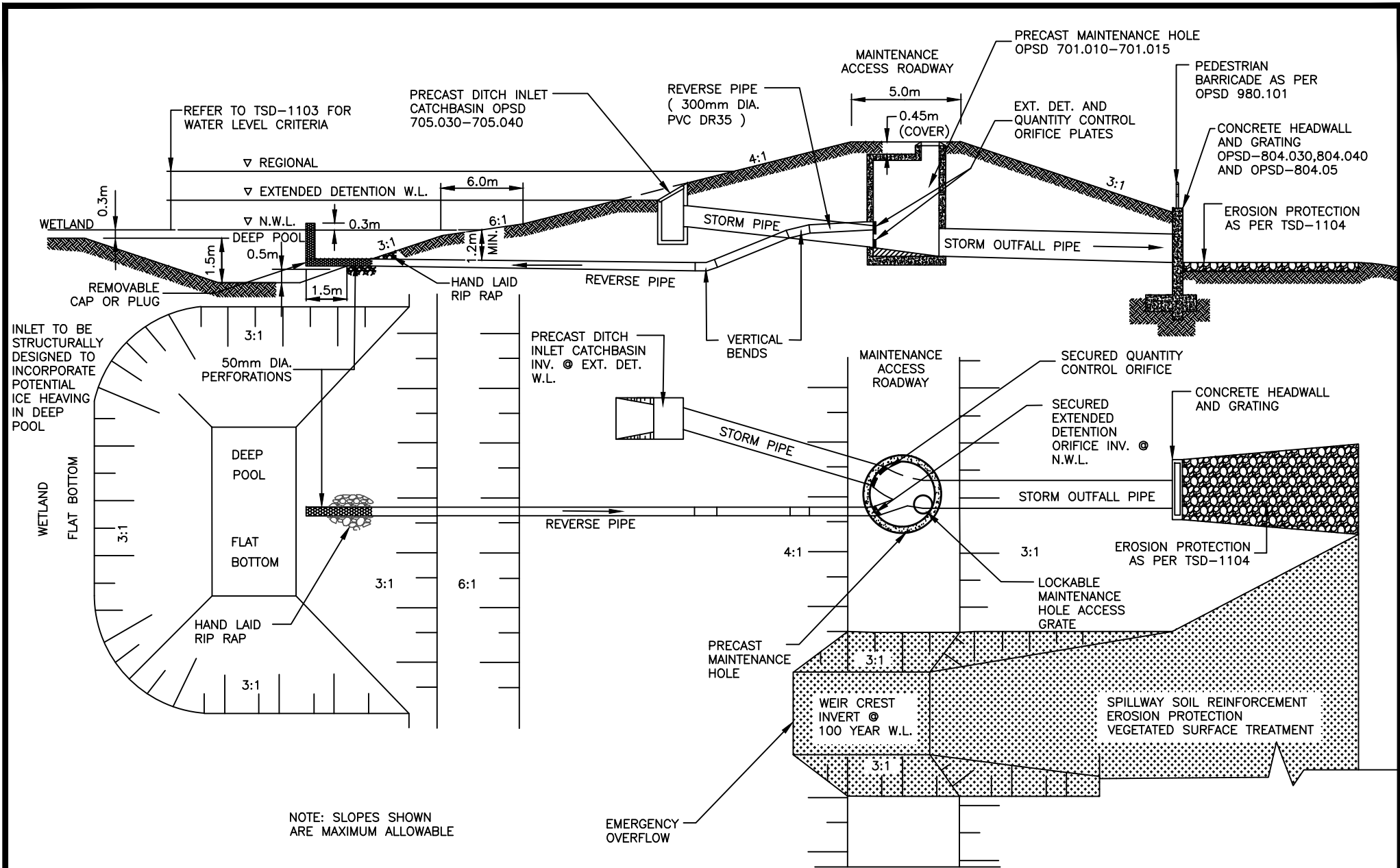

# OUTLET STRUCTURE TYPICAL DETAIL WETLAND FACILITY WITHOUT MAINTENANCE PIPE

**APPROVED**

MANAGER OF ENGINEERING ..... DATE .....

DIRECTOR OF OPERATIONS ..... DATE .....

REVISION No. .... DATE: FEB 2022

SCALE: N.T.S.

**TSD-1101**

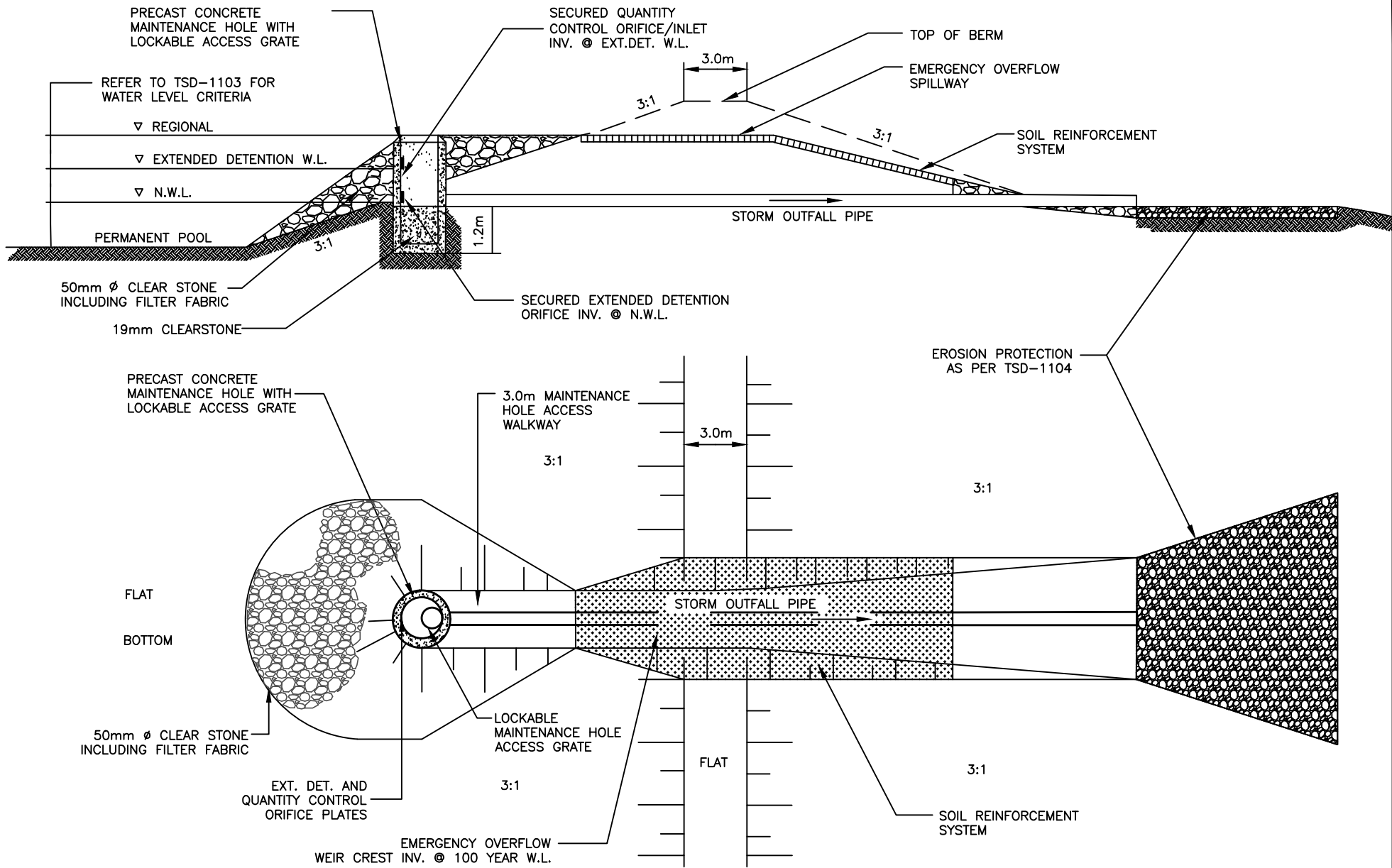

STANDARD DETAIL

# TEMPORARY OUTLET STRUCTURE TYPICAL DETAIL

APPROVED

MANAGER OF ENGINEERING DATE  
 DIRECTOR OF OPERATIONS DATE

REVISION No. DATE: FEB 2022  
 SCALE: N.T.S.

TSD-1102

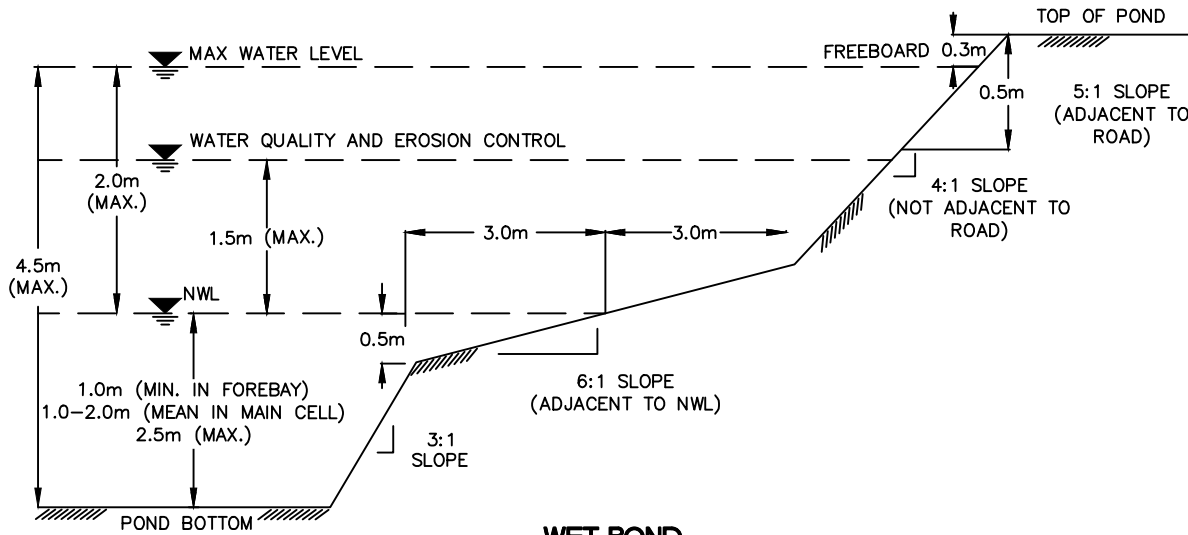

**WET POND**  
N.T.S.

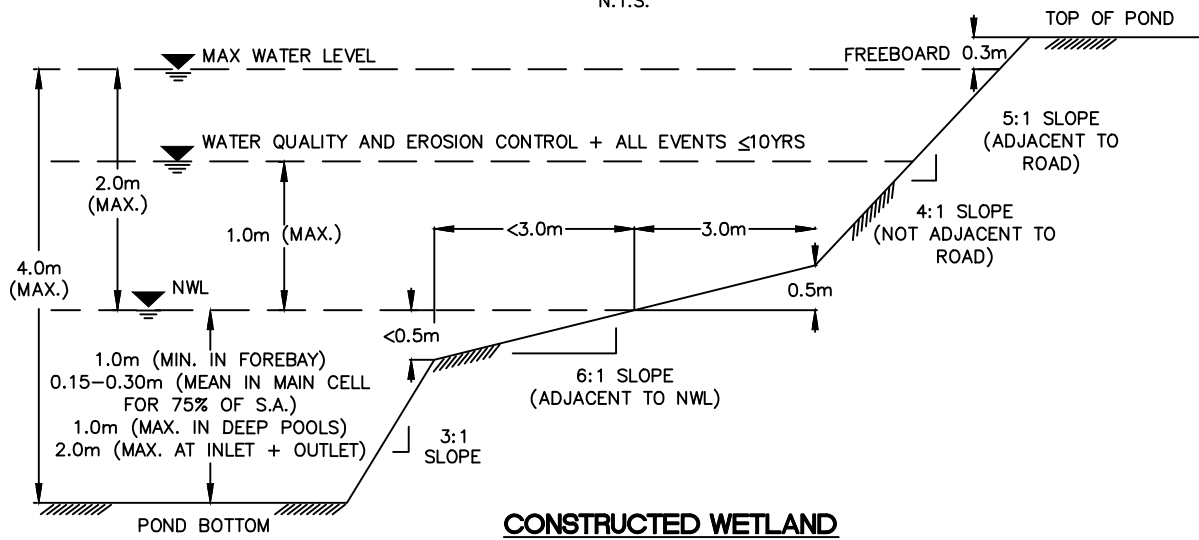

**CONSTRUCTED WETLAND**

**NOTES:**

FOR HYBRID WET POND / WETLAND FACILITIES, THE ABOVE NOTED CRITERIA FOR DEPTH AND SLOPE SHALL APPLY TO THE RESPECTIVE WET POND AND WETLAND COMPONENTS OF THE HYBRID FACILITY WITH THE FOLLOWING CLARIFICATION:

1. DEPTH FOR ACTIVE STORAGE SHALL NOT EXCEED THE CRITERIA FOR A WETLAND UNLESS A TERRACED OVERFLOW CONFIGURATION IS EMPLOYED.
2. THE MINIMUM LENGTH TO WIDTH RATIO FOR THE WET POND COMPONENT SHALL BE 2:1.



**STANDARD DETAIL**

**SWM FACILITY GRADING AND WATER LEVEL CRITERIA**

**APPROVED**

MANAGER OF ENGINEERING      DATE  
DIRECTOR OF OPERATIONS      DATE

REVISION No.      DATE: MARCH 2020  
SCALE: N.T.S.

**TSD-1103**

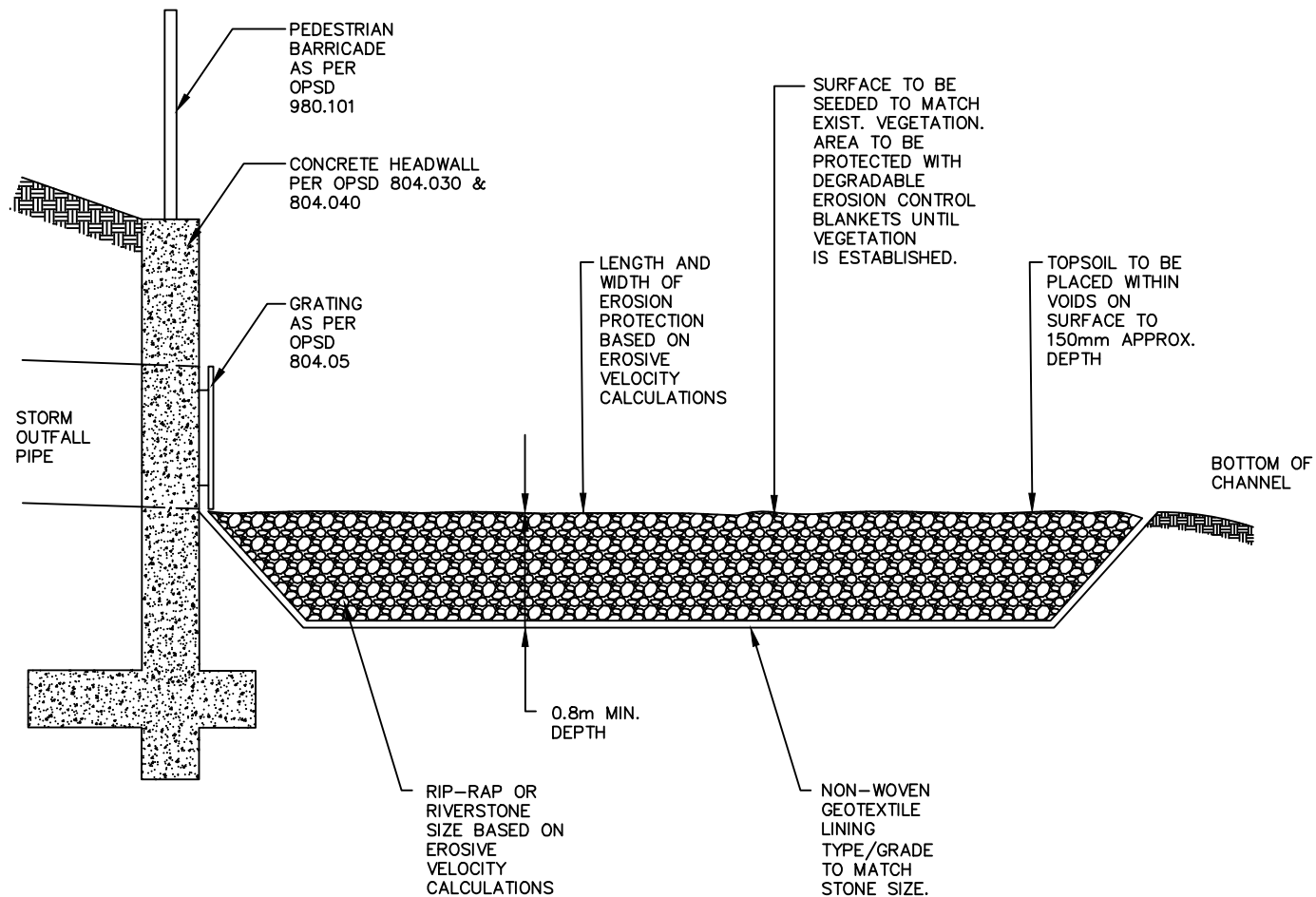

STANDARD DETAIL

# OUTLET EROSION PROTECTION TYPICAL DETAIL

APPROVED

MANAGER OF ENGINEERING DATE

DIRECTOR OF OPERATIONS DATE

REVISION No. DATE: MARCH 2020

SCALE: N.T.S.

TSD-1104

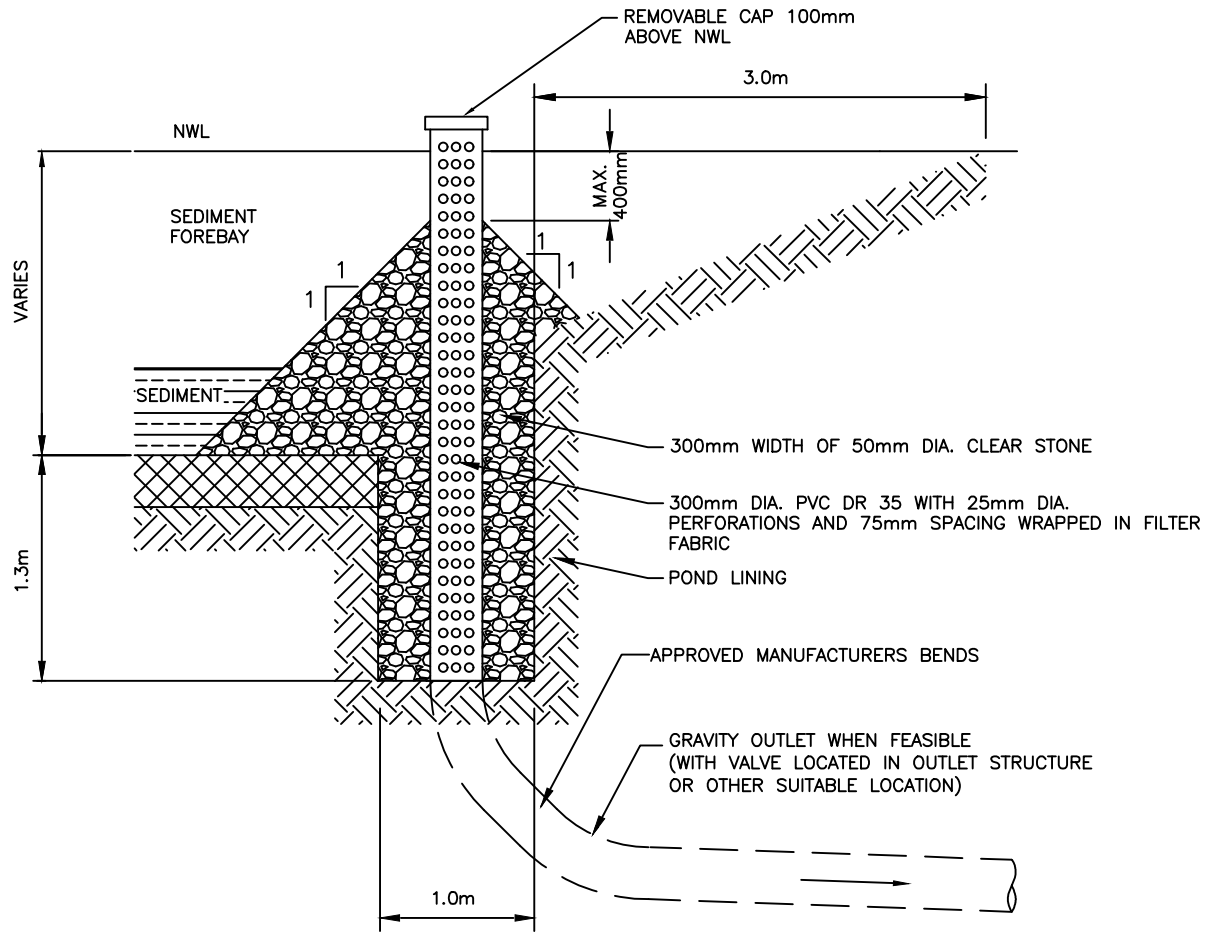

STANDARD DETAIL

# FOREBAY HICKENBOTTOM DETAIL

APPROVED

MANAGER OF ENGINEERING DATE  
DIRECTOR OF OPERATIONS DATE

REVISION No. DATE: MARCH 2020  
SCALE: N.T.S.

TSD-1105



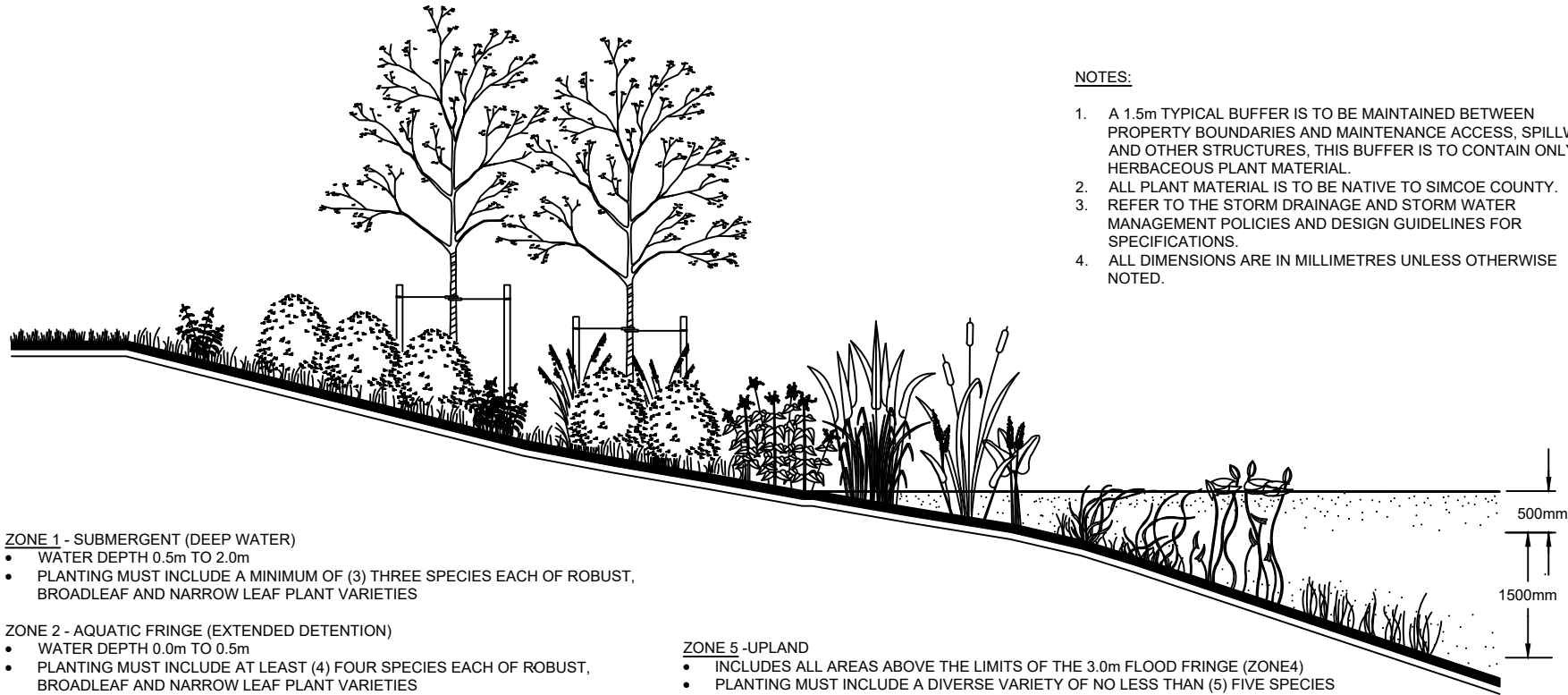

**NOTES:**

1. A 1.5m TYPICAL BUFFER IS TO BE MAINTAINED BETWEEN PROPERTY BOUNDARIES AND MAINTENANCE ACCESS, SPILLWAYS AND OTHER STRUCTURES, THIS BUFFER IS TO CONTAIN ONLY HERBACEOUS PLANT MATERIAL.
2. ALL PLANT MATERIAL IS TO BE NATIVE TO SIMCOE COUNTY.
3. REFER TO THE STORM DRAINAGE AND STORM WATER MANAGEMENT POLICIES AND DESIGN GUIDELINES FOR SPECIFICATIONS.
4. ALL DIMENSIONS ARE IN MILLIMETRES UNLESS OTHERWISE NOTED.

**ZONE 1 - SUBMERGENT (DEEP WATER)**

- WATER DEPTH 0.5m TO 2.0m
- PLANTING MUST INCLUDE A MINIMUM OF (3) THREE SPECIES EACH OF ROBUST, BROADLEAF AND NARROW LEAF PLANT VARIETIES

**ZONE 2 - AQUATIC FRINGE (EXTENDED DETENTION)**

- WATER DEPTH 0.0m TO 0.5m
- PLANTING MUST INCLUDE AT LEAST (4) FOUR SPECIES EACH OF ROBUST, BROADLEAF AND NARROW LEAF PLANT VARIETIES

**ZONE 3 - SHORELINE FRINGE (EXTENDED DETENTION)**

- 1.0m (HORIZONTAL) FROM THE PERMANENT POOL ELEVATION
- PLANTING ZONE TO CONTAIN WETLAND SPECIES AND MUST INCLUDE PERENNIAL SEDGES, RUSHES AND WILD FLOWERS IN COMBINATION WITH SHRUBS AND WETLAND SEED MIX

**ZONE 4 - FLOOD FRINGE**

- 2.0m (HORIZONTAL) FROM LIMIT OF SHORELINE FRINGE LIMIT OR TO THE 100 YEAR FLOOD LEVEL (WHICHEVER IS GREATER)
- PLANTING MUST INCLUDE A DIVERSE VARIETY OF NO LESS THAN (4) FOUR TOLERANT SPECIES EACH OF SHRUBS, DECIDUOUS TREES, CONIFEROUS TREES AND AN UPLAND SEED MIX

**ZONE 5 - UPLAND**

- INCLUDES ALL AREAS ABOVE THE LIMITS OF THE 3.0m FLOOD FRINGE (ZONE4)
- PLANTING MUST INCLUDE A DIVERSE VARIETY OF NO LESS THAN (5) FIVE SPECIES EACH OF DROUGHT TOLERANT SHRUBS, DECIDUOUS TREES, CONIFEROUS TREES AND AN UPLAND SEED MIX



**STANDARD DETAIL**

# STORMWATER PLANTING ZONE COMPOSITION

**APPROVED**

.....  
MANAGER OF ENGINEERING                      DATE

.....  
DIRECTOR OF OPERATIONS                      DATE

REVISION No.

DATE: MARCH 2020

SCALE: N.T.S.

**TSD-1106**

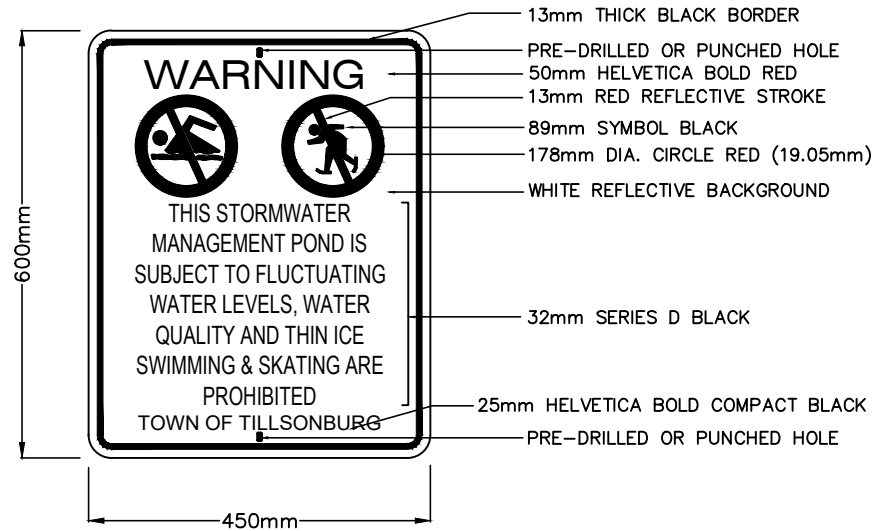
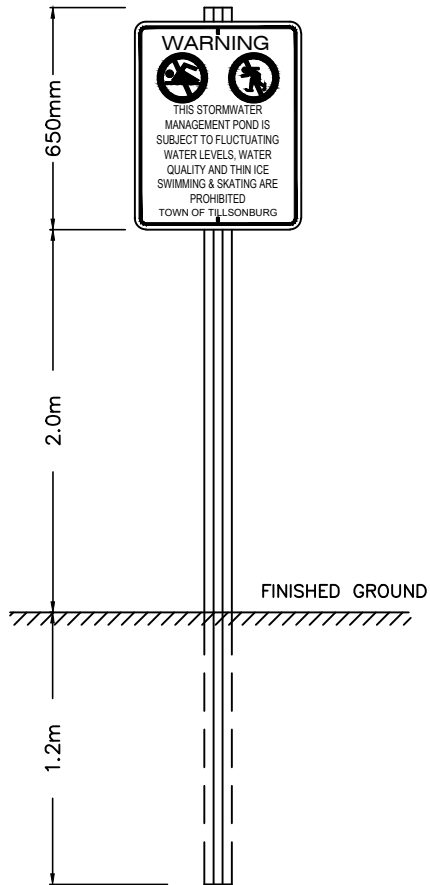

**SIGN REQUIREMENTS**

SIGN(S) MUST BE PLACED AT ALL POND ENTRANCES.

**SIGNAGE FACE**

SIGN(S) TO BE MANUFACTURED USING REFLECTIVE FINISH (ENGINEER GRADE) 3.2mm THICK ALUMINUM PANEL (50mm RADIUS CORNERS), WITH TOP AND BOTTOM MOUNT HOLES.

**MOUNTING**

SIGN(S) TO BE MOUNTED TO 3.85m U-CHANNEL GALVANIZED STEEL POST.



STANDARD DETAIL

# STORMWATER MANAGEMENT POND WARNING SIGN

APPROVED

.....  
MANAGER OF ENGINEERING                      DATE

.....  
DIRECTOR OF OPERATIONS                      DATE

REVISION No.                      DATE: DEC 2021

SCALE: N.T.S.

**TSD-1110**